

READ THIS FIRST:

Read and follow all instructions carefully before beginning installation.

7-WAY Blade Wiring Adapters

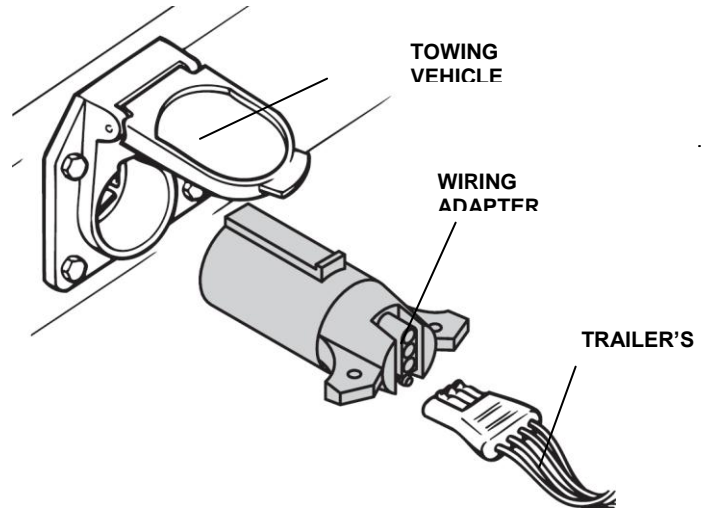
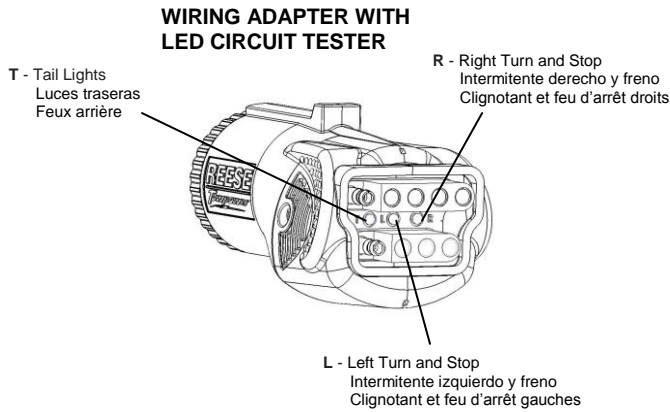

VEHICLE'S CONNECTOR	FUNCTIONS OF WIRING ADAPTER	TRAILER'S PLUG	CCP P/N
<p>7-Way Blade, RV Type</p>	7-Way Blade To 4-way Flat	4-way Flat	74607
	7-Way Blade To 4-way Flat with LED tester		78116
	7-Way Blade To 4-way Flat, Retractable		78007
	7-Way Blade To 4-way Flat Tow-Glo		78117
	7-Way Blade To 6-way Round	6-way Round Pin	85216
	Combo 7-Way Blade To 6 way Round with Back-up alarm		74685
	Combo 7-Way Blade To 7-way Blade with Back-up alarm	7-way Blade	74680
	Combo 7-Way Blade To 4 & 5 way Flat with Back-up alarm		74679
	Combo 7-Way Blade To 4 & 5 way Flat	4-way or 5-way Flat	74678
	Combo 7-Way Blade To 4 & 5 way Flat with LED tester		85212
	Combo 7-Way Blade To 4 & 5 Flat with LED tester & 12V outlet		78118
	Combo 7-Way Blade To 6-way Round & 4 Flat with LED tester	6-way Round Pin or 4-way Flat	78119
			85350*

Plug wiring adapter into tow vehicle side connector to allow electrical connections between 7-way Blade Receptacle with variety of the trailer Plugs.

NOTE:

Wiring Adapters equipped with the built-in LED circuit testers will confirm that each connection is operating properly. Refer to the LED lights diagram shown.

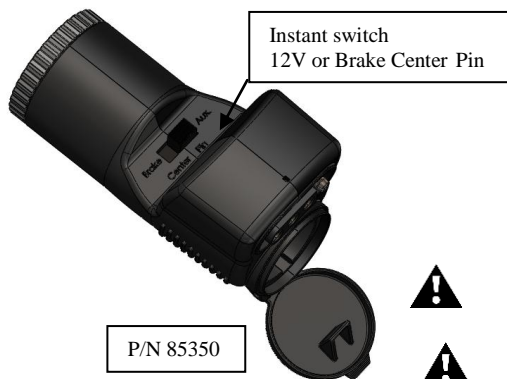

INSTANT SWITCH INSTRUCTIONS *:

1. Determine which circuit is located on the center pin of the 6-PIN Trailer Connector (either BRAKE or Auxiliary).
2. Slide switch on bottom of Adapter to match with the trailer Center Pin function.
3. Test connections to be sure all circuits are connected properly before towing.

WARNING

All connections must be complete to function properly. Test and verify installation with a test light, circuit tester or trailer once installed.

WARNING

Overloading circuit can cause fires. **DO NOT** exceed lower of towing manufacturer rating or:

- Max. Right Turn, Left Turn, Stop, & Tail Light Circuits: (7.5 amps)
- Max. (+) Battery, Reverse, and Electric Brake Circuits: (30 amps)

Read vehicle's owners manual & instruction sheet for additional information. Additional fusing maybe required.