

WeatherTech® No-Drill MudFlap

Installation Instructions

Thank you for purchasing the WeatherTech® No-Drill MudFlap. Please read this installation guide to thoroughly familiarize yourself with the steps to install the MudFlap on your vehicle. When properly installed, the WeatherTech® No-Drill MudFlap will provide you with years of protection.

⚠ WARNING ⚠

The MudFlap is designed to fit vehicles with standard size wheels and tires. Installation of MudFlaps on vehicles with aftermarket wheels or oversize tires may interfere with the MudFlap, will void the warranty and may damage the MudFlap or the vehicle.

	Tools Needed
	- Ratchet and Socket Set
	Hardware
	Installation will require using the OEM fasteners already on the vehicle.

1 Start by thoroughly washing your vehicle. Take care to remove all dirt, debris, and stains from each fender in the areas corresponding to where the MudFlaps will be installed.

2 Park the vehicle on level ground with the wheels turned fully to the left. Begin with the driver's side MudFlap installation.

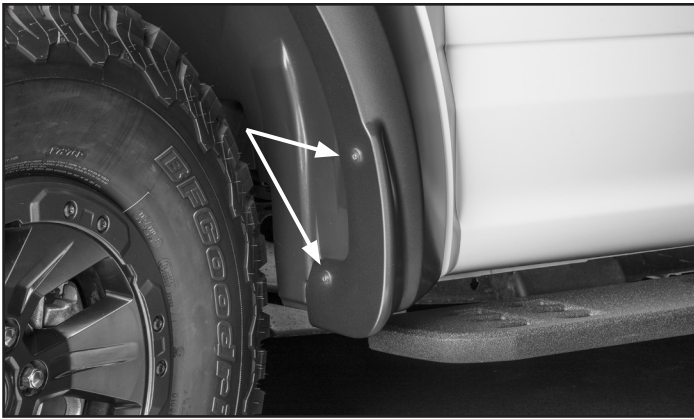

3 Locate the (2) factory hex head screws as indicated.



4 Using a ratchet and appropriate socket, remove the (2) factory hex head screws. They will be reused.



5 Using the MudFlap marked "LH," place it up to fender and align with the corresponding holes. Next, begin to re-install the (2) previously removed factory hex head screws by hand.



6 With the MudFlap pressed firmly against the fender, fully tighten the (2) previously removed factory hex head screws with the ratchet and appropriate socket.



7 Install the passenger side MudFlap marked “RH,” with the wheels turned fully to the right, repeating steps 3-6.

Congratulations!
Your new WeatherTech® No-Drill MudFlaps have been installed!



Made in the USA

WeatherTech® No-Drill MidFlap

Installation Instructions

Thank you for purchasing the WeatherTech® No-Drill MidFlap. Please read this installation guide to thoroughly familiarize yourself with the steps to install the MidFlap on your vehicle. When properly installed, the WeatherTech® No-Drill MidFlap will provide you with years of protection.

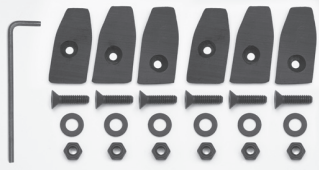
	Tools Needed - Ratchet and 7/16" Deep Socket
	Hardware <u>48MF566 Parts Kit:</u> (1) Allen Hex Key (1) Plastic Plug Assembly Kit with 6 Plugs (6) Flat Head Cap Screws (6) Flat Washers (6) Nylon-insert Locknuts

1 Start by thoroughly washing your vehicle. Take care to remove all dirt, debris, and stains from each running board in the areas corresponding to where the MidFlaps will be installed.

2 Park the vehicle on level ground. Begin with the driver's side MidFlap installation.

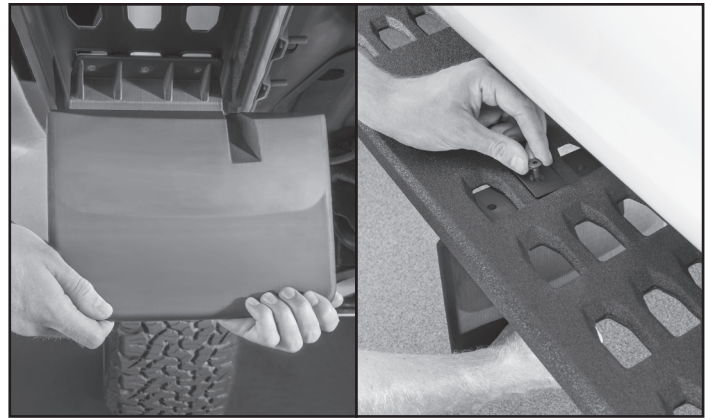

View: underside of running board

3 Locate a position on the running board where the MidFlap will be attached. (See diagram below)

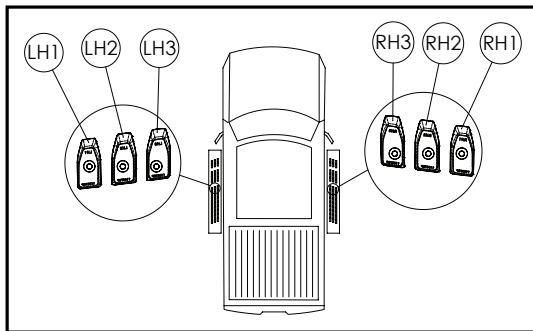

4 Place the MidFlap marked "LH," up to the underside of the running board while lining up to the holes in the board. Next, take the supplied plastic plug marked "LH2," and place it in the middle hole of the running board. Then, take (1) supplied flat head cap screw and put it through the plug and MidFlap.

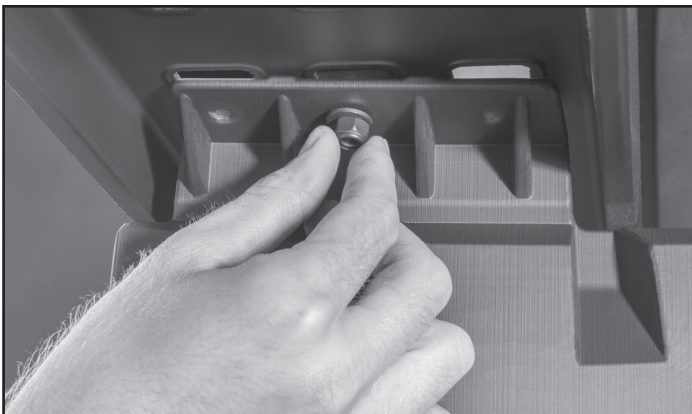

View: underside of running board

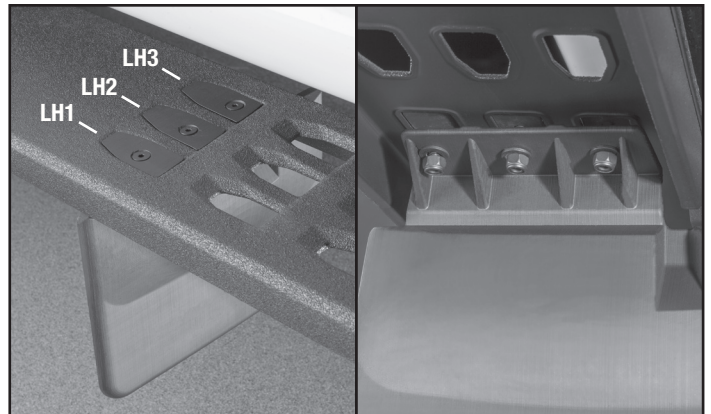

View: underside of running board

5 Take (1) supplied flat washer and (1) supplied nylon-insert locknut and turn it on the screw thread to hold the MidFlap onto the running board so remaining hardware can be attached.

6 Repeat Steps 4 and 5 with the two remaining supplied plastic plugs and hardware with "LH1" being the outermost plug and "LH3" being the innermost plug on the running board.

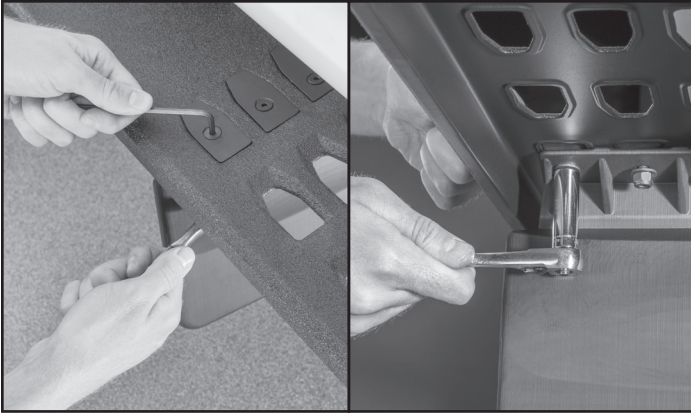

View: underside of running board

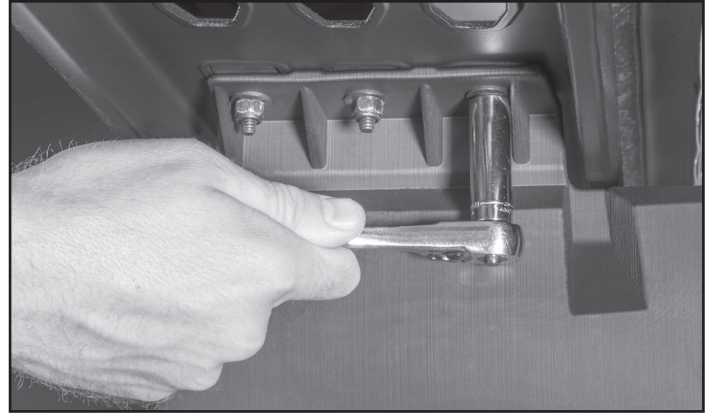

View: underside of running board

7 Once each locknut has been started on each screw thread, place and hold the supplied Allen hex key on top of one of the flat head screws. Then, use a ratchet and 7/16" deep socket on the corresponding locknut and tighten to a snug fit. Repeat for each fastener set.

8 With the MidFlap positioned correctly on the running board, fully tighten the (3) plug and fastener sets.

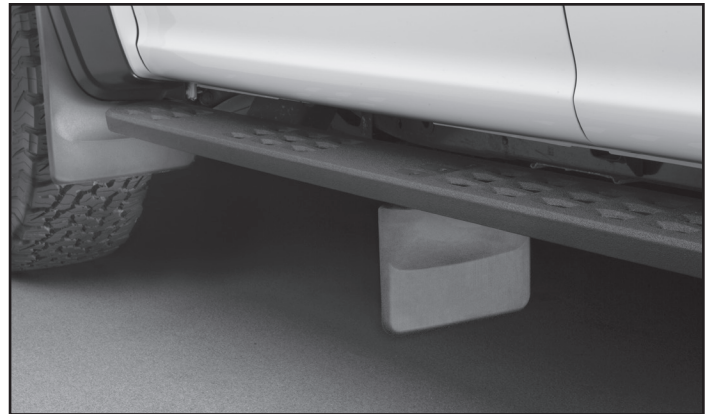
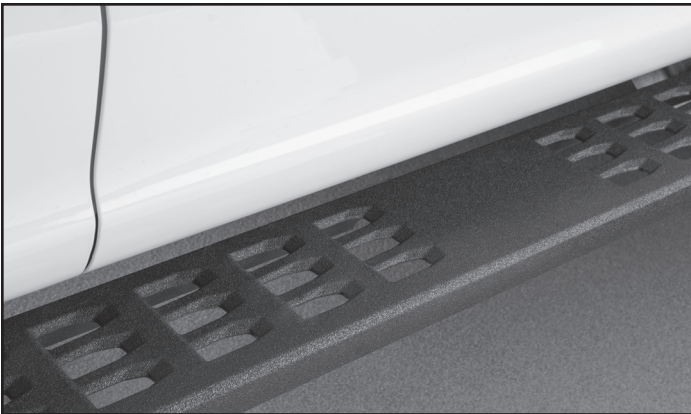

9 Install the passenger side MidFlap marked "RH," repeating Steps 3-8.

Congratulations!
Your new WeatherTech® No-Drill MidFlaps have been installed!



Made in the USA



WeatherTech® No-Drill MudFlap

Installation Instructions

Thank you for purchasing the WeatherTech® No-Drill MudFlap. Please read this installation guide to thoroughly familiarize yourself with the steps to install the MudFlap on your vehicle. When properly installed, the WeatherTech® No-Drill MudFlap will provide you with years of protection.

⚠ WARNING ⚠

The MudFlap is designed to fit vehicles with standard size wheels and tires. Installation of MudFlaps on vehicles with aftermarket wheels or oversize tires may interfere with the MudFlap, will void the warranty and may damage the MudFlap or the vehicle.

	Tools Needed <ul style="list-style-type: none">- Pliers- Ratchet and Socket Set- Phillips Screwdriver (Stubby Preferred)
	Hardware <p>Parts Kit: 48MF564</p> <ul style="list-style-type: none">(4) Phillips Head Screws(4) Black Flat Washers(4) Aluminum Washers(4) Serrated Locking Nuts

1 Start by thoroughly washing your vehicle. Take care to remove all dirt, debris, and stains from each fender in the areas corresponding to where the MudFlaps will be installed.

2 Park the vehicle on level ground. Begin with the driver's side MudFlap installation.

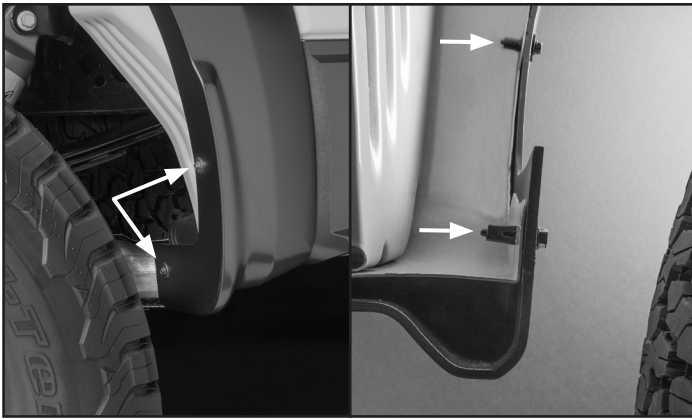

View: inside of fender



3 Locate the (2) factory Phillips head screws and (2) factory plastic clips as indicated.

4 Using a ratchet and appropriate socket, remove the (2) factory Phillips head screws. They will not be reused.

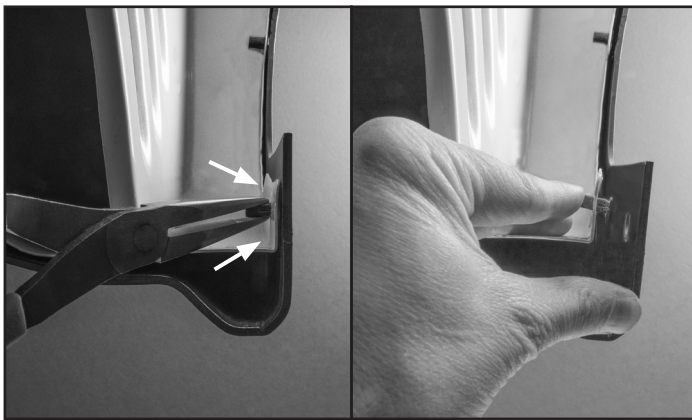

View: inside of fender



5 Using pliers, squeeze each factory plastic clip and push out through the fender for removal. Pulling the fender flare out toward the tire will assist in the plastic clips being removed. They will not be reused.

6 Using the MudFlap marked "LH," place it up to fender and align with the corresponding holes.



View: inside of fender

7 While holding the MudFlap up to the fender, install (2) supplied Phillips head screws and (2) black flat washers by hand as shown.

8 Take (2) supplied aluminum washers and place them against the inside of the fender as shown. Then, take (2) supplied serrated locking nuts and turn them clockwise on the screw thread until they are snug against each washer.



9 With the MudFlap pressed firmly against the fender, fully tighten the (2) Phillips head screws with the stubby Phillips screwdriver.

10 Install the passenger side MudFlap marked "RH," repeating steps 3-9.



Congratulations!

Your new WeatherTech® No-Drill MudFlaps have been installed!



Made in the USA