

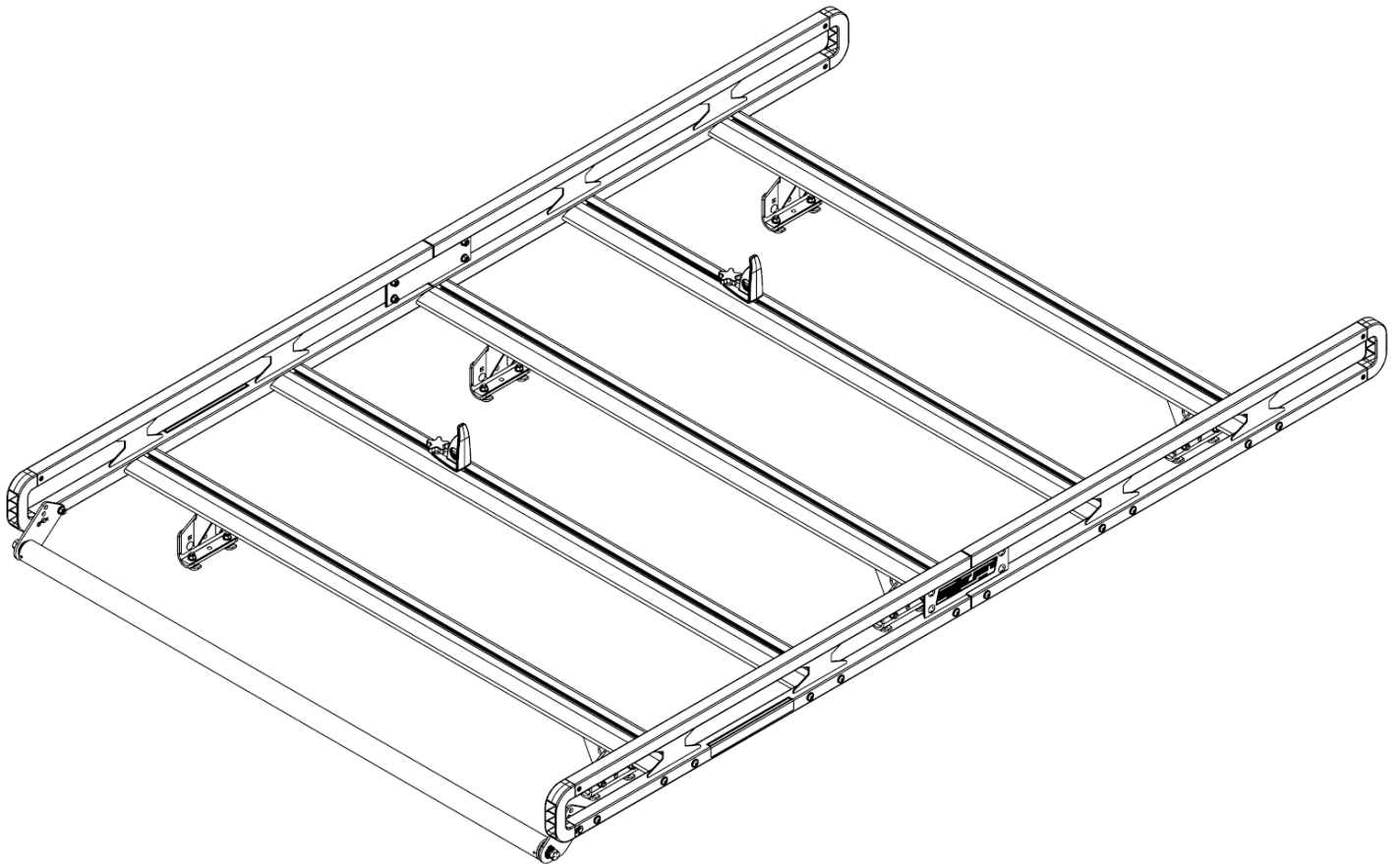

VAN STORAGE SOLUTIONS

**INSTALLATION INSTRUCTIONS for
ALUMINUM SAFARI RACK COMPACT**



MODEL ASRC001

Weather Guard / WERNER CO.
420 E. Terra Cotta Ave.
Crystal Lake, IL 60014 USA

800-456-7865 (Toll Free)
800-334-2981 (Fax)

Weather Guard / WERNER CO.
9133 Leslie St. Unit 105
Richmond Hill, ON L4B4N1

888-562-2251 (Toll Free)
888-456-8460 (Fax)

INSTALLATION GUIDELINES

- WEATHER GUARD® safari racks are designed to work with WEATHER GUARD® Mounting Channel kits to provide the best support for your load and to take advantage of OEM provided roof mounting points. If you have not already installed the mounting channel kit to the van roof, install it now before proceeding.
- Review vehicle manufacturer's roof mount recommendation.
- Perform the installation on a level surface.
- Always wear protective eyewear to keep debris out of your eyes when installing WEATHER GUARD® Van Products.
- Tighten all 5/16" hardware to 13 ft-lb when ready.
- Tighten all 1/4" hardware to 76 in-lb when ready.
- **This product is designed and intended for use on the following vehicles: Ford Transit Connect, Ram ProMaster City, Mercedes Metris, Chevrolet City Express, and Nissan NV200.**

OPERATION GUIDELINES

- Ladders transported on a vehicle should be properly supported and the overhang of the ladders beyond supporting points should be limited. Transporting a ladder with excessive overhang can result in reduced ladder life. Inspect your ladder before each use. Follow ANSI 14.2-2007 for direction on securing ladders to ladder racks.
- Payload should be centralized on the rack front to back whenever possible and securely tied to the side rails and the cross members. Payload should be evenly distributed as much as possible and the heavier items directly above the mounting feet. Failure to do so may cause damage to the rack and/or vehicle.
- Follow manufacturers' roof loading guidelines. Misuse can result in injuries or death, damages to the vehicle and/or other vehicles, and will void WG warranty.
- It is the responsibility of the user to secure the load to the rack before transporting.
- Any modifications made to this product, or use of this product for any other purpose than its intended use, could create a hazardous condition that can cause serious personal injury or property damage.
- **At the end of the first week of use, check all of the fasteners for proper tightness and then check every three months thereafter.**

HARDWARE KIT

DESCRIPTION	QTY
5/16-18 x 5/8" Carriage Bolt	8
5/16-18 x 7/8" Carriage Bolt	20
5/16-18 x 1-1/4" Carriage Bolt	12
5/16-18 x 2" Button Head Bolt	20
5/16" Washer	38
5/16-18 Nylon Lock Nut	38
1/4-20 x 3/8" Set Screw	2
1/2-13 x 2-3/4" Bolt	2
Bushing	20
Carriage Bolt Plate	20
Knob	2

TOOLS REQUIRED
1/8" Allen Key/Socket
3/16" Allen Key/Socket
1/2" Socket
1/2" Wrench
3/4" Socket
Ratchet
Measuring Tape or Ruler
Torque wrench

PARTS LIST

DESCRIPTION	QTY
Ladder Stop	2
Mounting Foot	6
Roller Tube	1
Crossmember	5
Connecting Cap	4
Mounting Foot Bolt Plate	6
J-Bracket	6
Front Left End Rail	1
Front Right End Rail	1
Rear Left End Rail	1
Rear Right End Rail	1

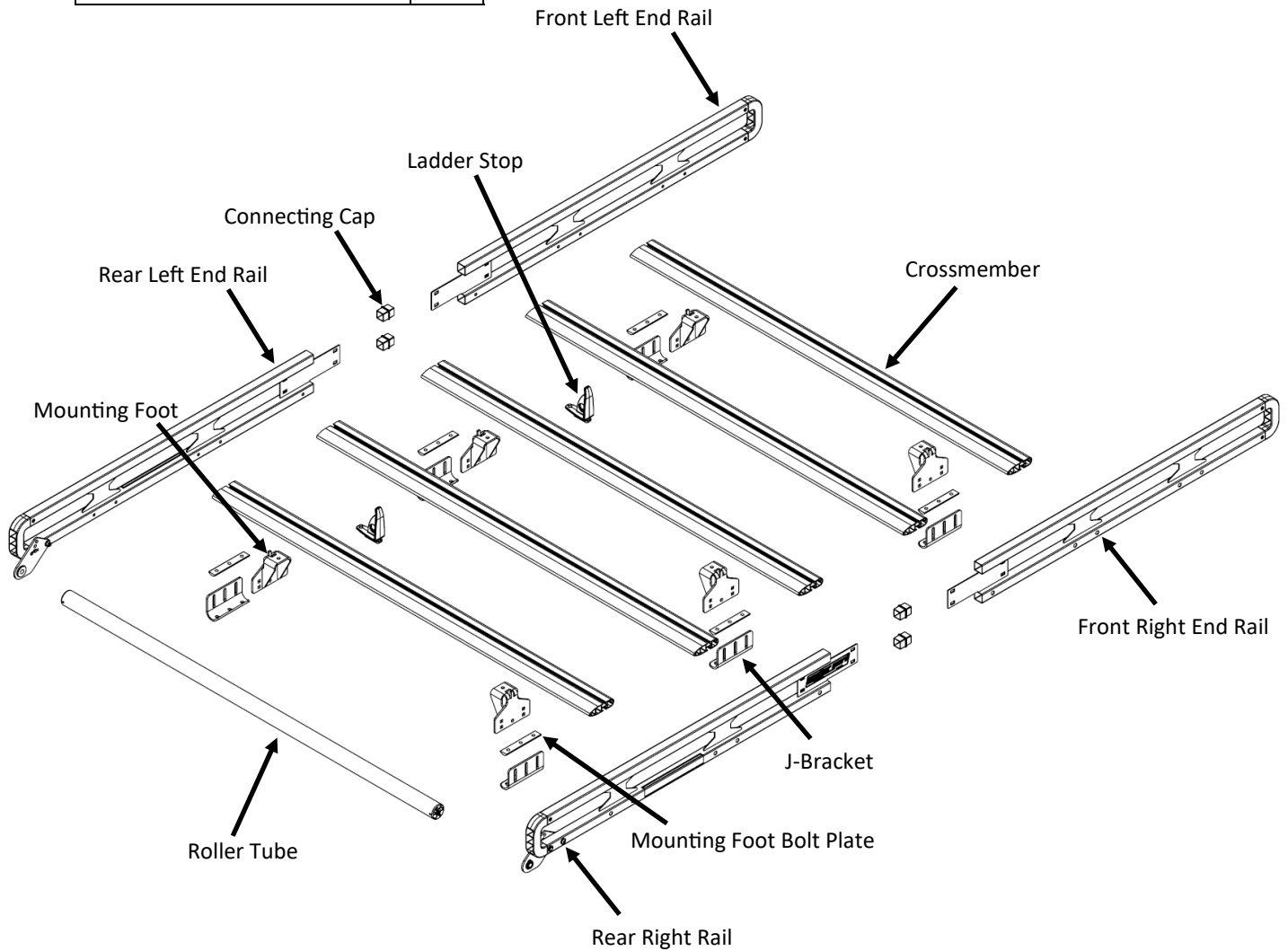

RACK ASSEMBLY INSTRUCTIONS

STEP 1. Install Mounting Channel Kit to the Van Roof following its instructions.

STEP 2. Insert (2) Connecting Caps into Front Left End Rail (larger holes on the bottom outside). With the larger holes on the bottom outside, slide the Rear Left End Rail over the other end of the caps. Assemble together using (4) 5/16-18 x 5/8" carriage bolts, washers, and nylon lock nuts. Tighten to 150 in-lb or 13 ft-lb. Do NOT use impact tools to tighten.

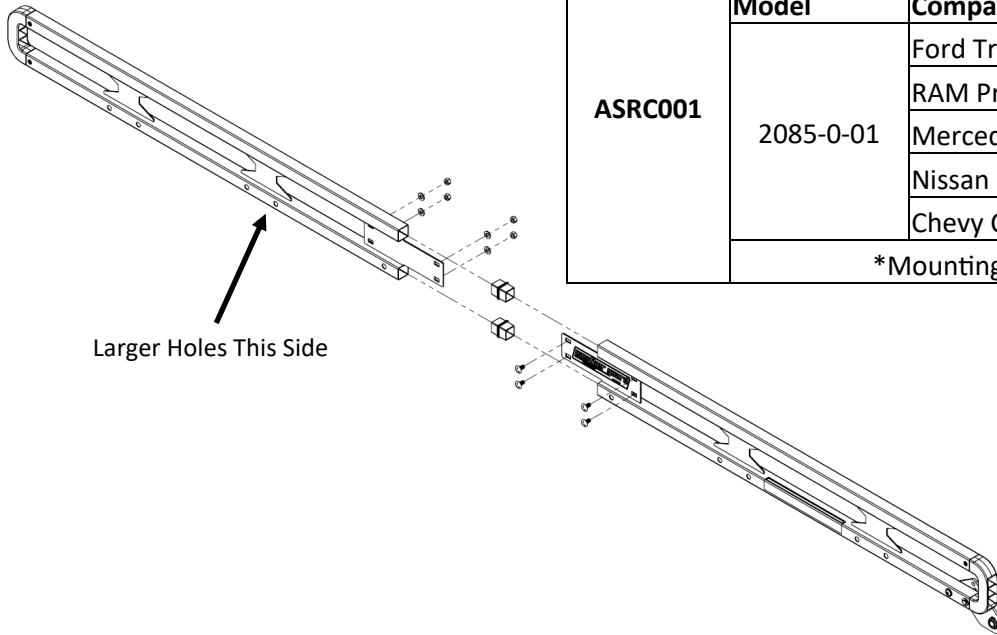

		Roof Rack Mounting Kit	
		Model	Compatibility
ASRC001	2085-0-01		Ford Transit Connect 105" & 120"
			RAM Promaster City
			Mercedes Metris
			Nissan NV200
			Chevy City Express
		*Mounting kits sold separately	

STEP 3. Insert (2) Connecting Caps into Front Right End Rail (larger holes on the bottom outside). With the larger holes on the bottom outside, slide the Rear Right End Rail over the other end of the caps. Assemble together using (4) 5/16-18 x 5/8" carriage bolts, washers, and nylon lock nuts. Tighten to 150 in-lb or 13 ft-lb. Do NOT use impact tools to tighten.

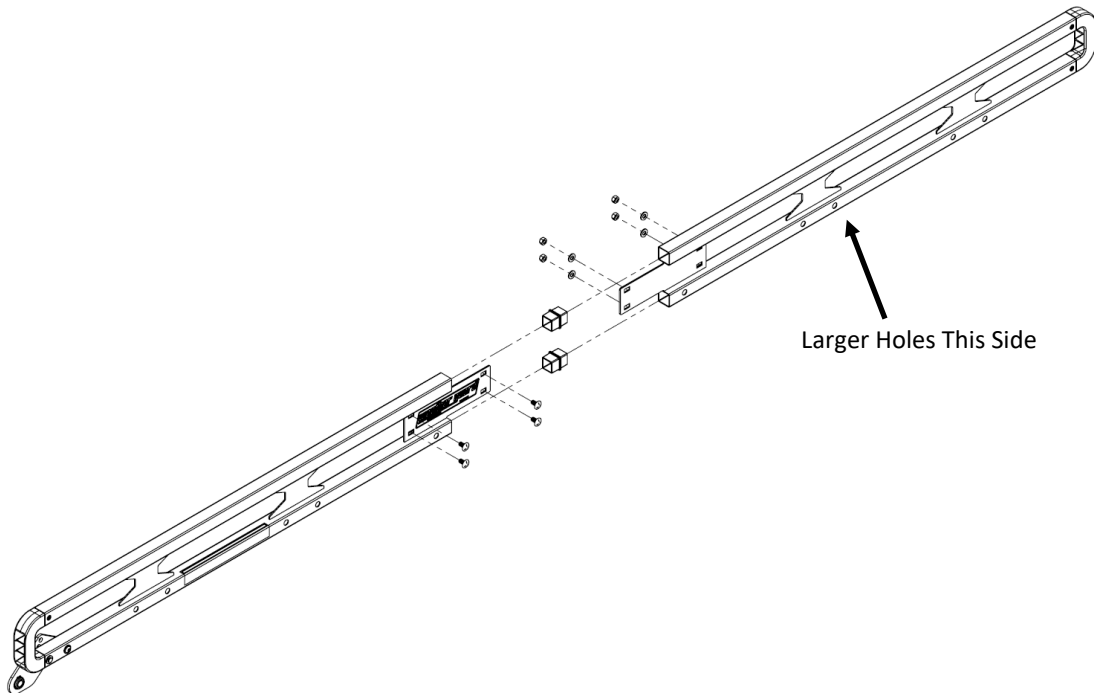

RACK ASSEMBLY INSTRUCTIONS

STEP 4. Loosely assemble a 5/16-18 x 7/8" carriage bolt, plate, and knob to each of the Ladder Stops as shown.

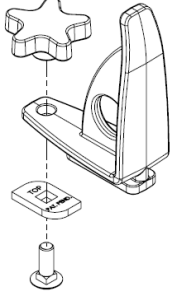

STEP 5. Align crossmembers to the end rails with the rounded/blunt end facing the front of the rack (away from the Roller Brackets).

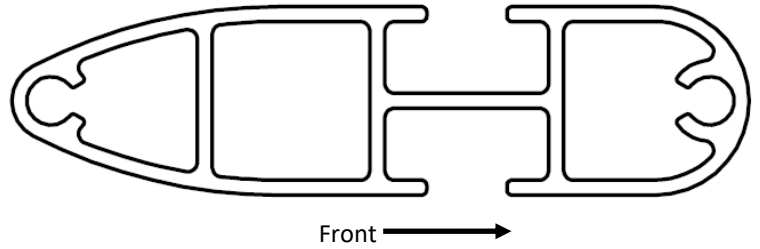

STEP 6

- Insert (2) 5/16-18 x 7/8" carriage bolts and plates into bottom of the 1st, 3rd, and 5th crossmembers.
- Insert a Ladder Stop assembly into top of the 2nd and 4th crossmembers. Feel free to tighten the knobs now as they can be adjusted by hand at any time later.
- Assemble End Rails to Crossmembers using (20) 5/16-18 x 2" button head bolts & (20) bushings. 150 in-lbs or 13 ft-lbs.
- Place Roller Tube between the Bearings and insert a 1/2-13 bolt through each Bearing and thread them into the ends of the Roller Tube. Tighten until the threads are fully engaged. Do NOT exceed 33 ft-lb.
- Thread a 1/4-20 set screw into each of the holes near the ends of the Roller Tube and tighten them to 76 in-lb to prevent the 1/2-13 bolts from loosening.

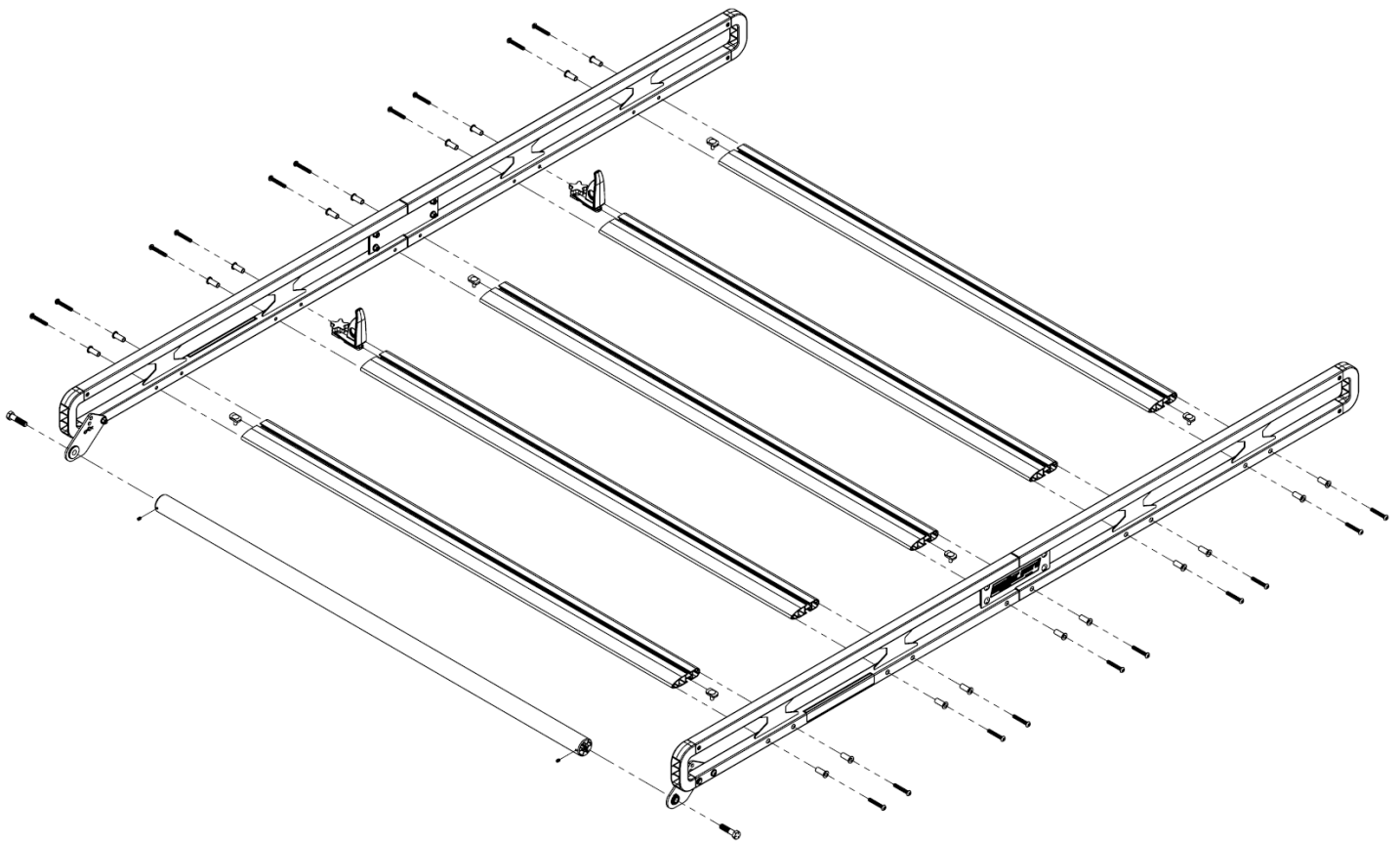

RACK ASSEMBLY INSTRUCTIONS

STEP 7

-Assemble a Mounting Foot to each of the previously-inserted carriage bolts in the bottom of the crossmembers using a washer and 5/16-18 nylon lock nut. Ensure the tabs sit within the groove of the crossmember and tighten the nut until the foot is snug and flat against the crossmember.
NOTE: For reference/starting dimensions for where to place the Mounting Feet for your vehicle, see the table and image below.

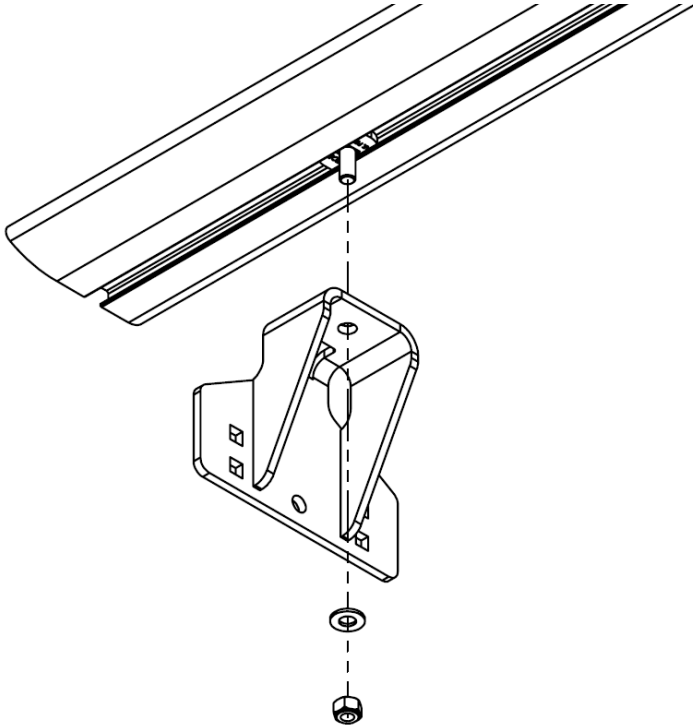

STEP 8

-Assemble a J Bracket to each Mounting Foot as shown below using (2) 5/16-18 x 7/8" carriage bolts, washers, and nylon lock nuts. Tighten until snug, but keep in mind that they may require adjustment during installation on the van.

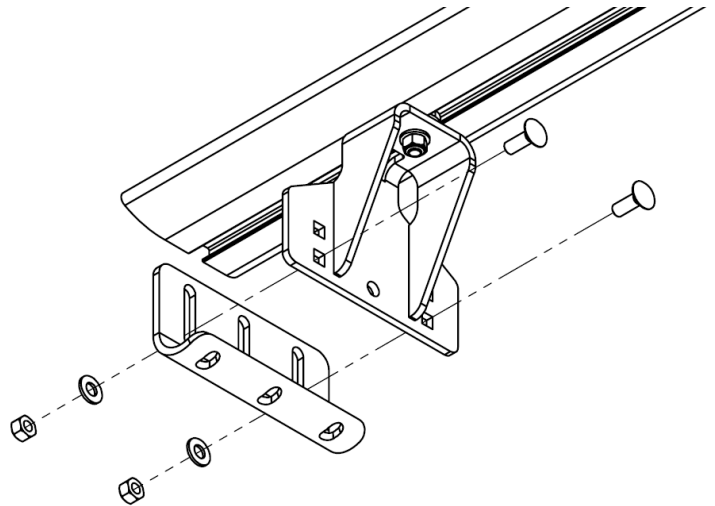

REFERENCE DIMENSIONS FOR MOUNTING FEET PLACEMENT IN STEP 7.

The following diagram and dimensions provide a decent starting point for placing the mounting feet along the cross-member. They are for reference only and will likely require adjustment upon the van roof to fit properly.

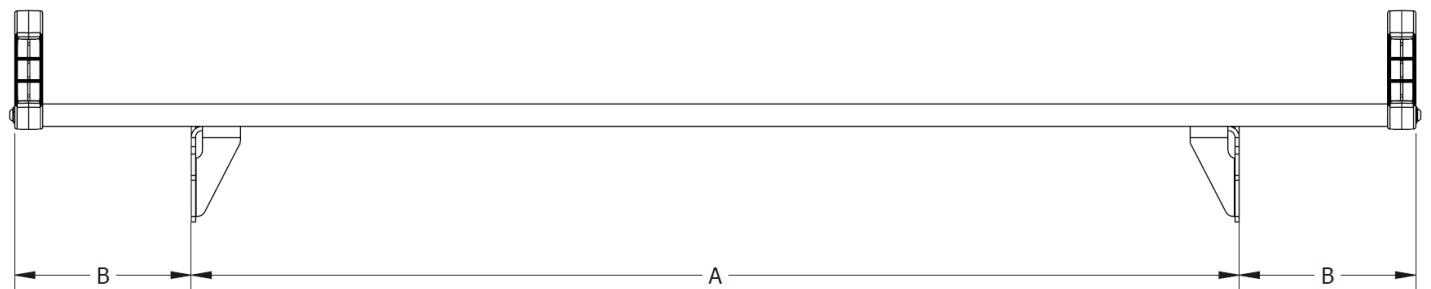

MOUNTING FOOT REF. DISTANCE		
VEHICLE	A	B
Transit Connect	46-3/4"	7-3/8"
ProMaster City	47-1/4"	7-5/8"
Metris	54-3/8"	4-1/16"
City Express/NV200	45"	8-3/4"

RACK INSTALLATION INSTRUCTIONS

STEP 9.

- With assistance, carefully lift rack assembly onto van roof. Set bottom of J Brackets on top of roof channels.
- Position rack front-to-back such that the roller protects the back of the van.

STEP 10

- Insert a 5/16-18 x 1-1/4" carriage bolt into each mounting plate with the bolt's thread on the side of the plate that says "TOP". Insert two carriage bolt/plate assemblies per mounting foot into the channel and rotate 90 degrees clockwise.
- Lift the assembled ladder rack and place it on the carriage bolts. Use (2) 5/16" washers, (2) 5/16-18 nylon lock nuts, and a bolt plate to loosely fasten each mounting foot.

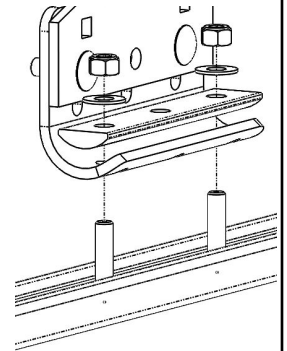
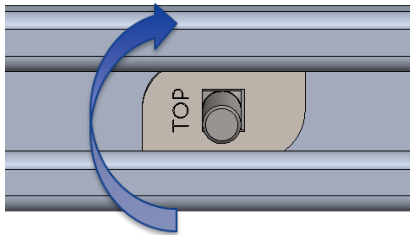

STEP 11.

- Use a level to adjust rack position left-to-right and front-to-back as needed and then tighten all the nuts to 150 in-lbs or 13 ft-lbs
- Adjust ladder stop positions left-to-right as desired and tighten knob.

OPTIONAL STEP 12.

- Adjust the load assist to a desired height by removing the clevis pin on both sides of the roller. Make sure the roller does not interfere with the rear view camera if the vehicle is equipped with one.

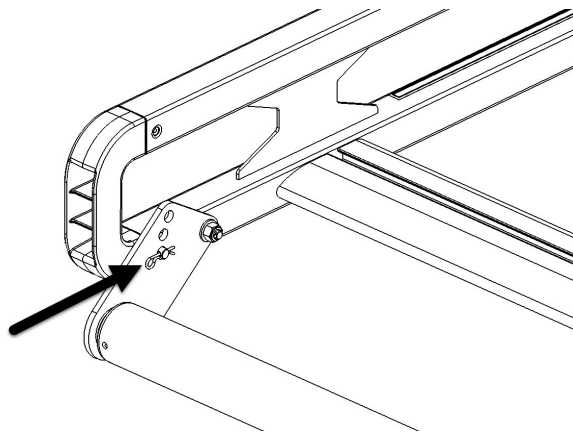

OPTIONAL STEP 13.

- If you want to remove the ladder stops later to allow for wider loads, loosen the knob, loosen the front pair of bolts attaching the crossmember to the end rails, remove the rear pair of bolts attaching the crossmember to the end rails (be careful not to lose the bushings), tilt the crossmember up or down to allow the ladder stop to slide out of the groove in the crossmember. If desired, you can re-insert the stop in the bottom groove for safe keeping. Reattach and re-tighten the crossmember bolts.

MAX LOAD CAPACITY

Model	Mfg Suggested Max Roof Load		Recommended Max Payload	WG Safari Rack Weight
Transit Connect	100 kg	220 lbs	162 lbs	58 lbs
Promaster City	68 kg	150 lbs	92 lbs	
NV200 / City Express	101 kg	222 lbs	164 lbs	
Metris	150 kg	330 lbs	272 lbs	

REPLACEMENT PARTS

P/N	DESCRIPTION
70145R	Ladder Stops (2 pc w/hardware)
70146R	Bolt Kit Upper
70148R	Bolt Kit Lower
70149R	Bolt Kit Roller
70151R	Roller Kit Compact
70152R	End Caps (4 pc)
70154R	Crossmember Compact (w/bolts & bushings)
70159R	Side Rail Set Comp (w/caps & hardware)
70161R	Mounting Bracket Kit (J-Bracket, Mounting Foot, Gutter Clamp, Hardware)

! WARNING

This product can reduce the driver's ability to clearly see roadways, vehicular or pedestrian traffic and other objects through the rear and side windows of the vehicle, which can cause an accident. Extra precautions should be taken when driving a vehicle with this product. Make all adjustments necessary to ensure maximum visibility, including but not limited to, changing mirror and seating positions. State and local laws may prohibit obstruction of windows in a moving vehicle.

These instructions are to be followed using the parts and fasteners supplied for proper installation. Any modifications or improper installation of this product will create a hazardous condition that could result in death, serious personal injury and/or property damage.

! CAUTION

Prior to drilling, so as not to cut electric wires, fuel lines, brake lines, etc., check behind and underneath drilling and mounting locations. To keep debris out of your eyes when checking the underside of the vehicle, or when drilling, always wear protective eye wear. Failure to heed this warning will result in death or serious injury.

- NOTICE -

Any modification or unintended use of this product shall immediately void all manufacturer's warranties. Manufacturer disclaims all liability for injuries to persons or property resulting from any modification to, or unintended use of this product.

WERNER CO. LIMITED LIFETIME WARRANTY FOR WEATHER GUARD® PRODUCTS

WEATHER GUARD® Products — Limited Lifetime Warranty (Purchased on or after 1/1/2009)

WERNER CO. (the "Manufacturer") warrants to the original purchaser only that WEATHER GUARD® Truck and Van Products (the "WEATHER GUARD® Product") will be free from defects in material and workmanship from the date of purchase and continuing for the expected lifetime of the WEATHER GUARD® Product. A copy of the original sales receipt must be supplied to the Manufacturer at the time a warranty claim is made. This warranty terminates if the original purchaser transfers the WEATHER GUARD® Product to any other person.

What is Covered

All WEATHER GUARD® Products identified above that are purchased on or after January 1, 2009.

What We Will Do to Correct Problems

Subject to the limitations and exclusions described in this limited warranty, the Manufacturer will remedy defects in materials or workmanship by providing one of the following remedies at its option and without charge to the original purchaser for parts or labor: (a) repairing the defective portion of the WEATHER GUARD® Product or (b) replacing the entire WEATHER GUARD® Product. In addition, the manufacturer may elect at its option, not to repair or replace the WEATHER GUARD® Product, but rather issue to the original purchaser a refund equal to the purchase price paid for the WEATHER GUARD® Product or a credit to be used toward the purchase of new WEATHER GUARD® Product.

What is Not Covered

This limited warranty expressly excludes:

- Defects caused by normal wear and tear, cosmetic rust, scratches, accidents, unlawful vehicle operation, or modification to the product, or any types or repair of a WEATHER GUARD® Product other than those authorized or provided by the Manufacturer.
- Defects resulting from conditions beyond the Manufacturer's control including, but not limited to misuse, overloading, or failure to assemble, mount or use the WEATHER GUARD® Product in accordance with the Manufacturer's written instructions or guidelines included with the WEATHER GUARD® Product or made available to the original purchaser.
- Damage to the contents of the box or vehicle.
- TO THE EXTENT PERMITTED BY LAW, IN NO EVENT SHALL THE MANUFACTURER BE LIABLE FOR ANY INCIDENTAL, SPECIAL, INDIRECT, OR CONSEQUENTIAL DAMAGES, INCLUDING ANY ECONOMIC LOSS, WHETHER RESULTING FROM NON-PERFORMANCE, USE, MISUSE OR INABILITY TO USE THE WEATHER GUARD® PRODUCT OR THE MANUFACTURER'S NEGLIGENCE.

No Other Express Warranty Applies

This Limited Lifetime Warranty is the sole and exclusive warranty for WEATHER GUARD® Products. No employee, agent, dealer, or other person is authorized to alter this warranty or make any other warranty on behalf of WERNER CO.

Notification Procedures

If the WEATHER GUARD® Product does not conform with the terms of this limited warranty, the original owner must promptly notify the Manufacturer in writing upon discovery of the nonconformity. In order to receive the remedies under this limited warranty, the warranty claim must describe the nature of the nonconformity, and a copy of the original sales receipt, invoice, bill or other proof of purchase must accompany the claim. Repairs or modifications made to the WEATHER GUARD® Product by other than the Manufacturer or its authorized agent will nullify this limited warranty. Coverage under this limited warranty is conditioned at all times upon the owner's compliance with these required notification and repair procedures. Warranty claims must include reciprocal contact information and may be made via certified mail to:

WERNER CO.

ATTN: Weather Guard® Warranty Claims
555 Pierce Road, STE 300 • Itasca, IL 60143 USA
weatherguard.com

If you have any questions, please call toll free at 1-800-456-7865