



**VAN STORAGE SOLUTIONS**

FOR THE WAY YOU WORK™

# INSTALLATION MANUAL

## WIRE SPOOL RACK 9861-3-01

**ATTENTION: PLEASE READ AND UNDERSTAND ALL INSTRUCTIONS AND WARNINGS BEFORE ASSEMBLING, INSTALLING OR USING THIS PRODUCT.**

### IMPORTANT BEFORE YOU BEGIN

Read these instructions and warnings completely before installing.

### BOLT KIT

Bolt Kit #32-8868 has been provided with your rack. Check this bolt kit to be sure the following parts are included:

| Quan. | Description                       |
|-------|-----------------------------------|
| 4     | 5/16-18 Nylon Lock Nut            |
| 8     | 5/16" Flat Washer                 |
| 1     | 5/16-18 Blind Fastener            |
| 1     | 5/16-18 x 1-1/4" Black Oxide Bolt |
| 4     | 5/16-18 x 1-1/4" Hex Hd. Bolt     |
| 1     | 5/16" Lock Washer                 |
| 1     | Installation Tool                 |
| 2     | Floor Mounting Spacers            |

### PARTS LIST

- 1- 8868 Spool Rack
- 1- Bolt Kit
- 2- Spindles

### TOOLS REQUIRED

- Electric Drill
- 3/8" & 1/2" Drill Bits
- 1/2" Wrenches (2)

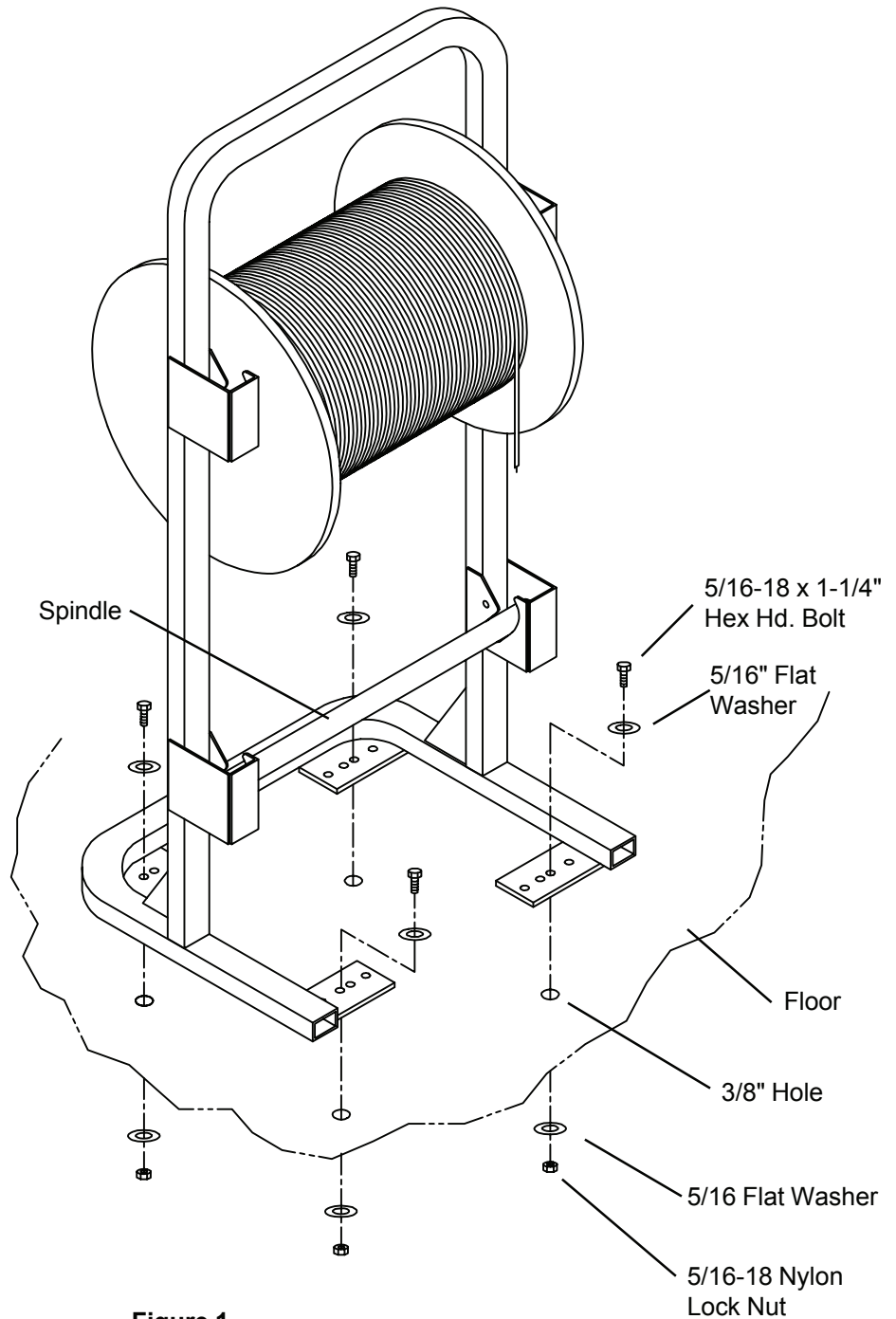

**Figure 1.**  
Typical Mounting

## INSTALLATION INSTRUCTIONS

1. Place the Wire Spool Rack in the desired position and mark the hole locations, choosing mounting holes that line up on top of ribs. If one set of holes do not line up with top of ribs, Floor Mounting Spacers should be used between ribs. (See Figure 2.)

### CAUTION

To keep debris out of your eyes when checking the underside of the vehicle, or when drilling, always wear protective eyewear.

### WARNING

Prior to drilling, so as not to cut or puncture fuel tanks, fuel lines, brake lines, electric wires, etc., check under vehicle for locations.

### WARNING

All floor mounting bolts near the gas tank area should be installed from the underside of the vehicle, to guard against the gas tank being punctured in the event of a collision. Do not use Blind Fastener in this area.

2. Drill hole locations.

**Note:** To prevent rust from occurring, touch-up any drilled holes.

3. Fasten the Wire Spool Rack to the floor. (See Figure 1.)

**NOTE -** One extra Blind Fastener and one extra lock washer have been provided for use in areas where standard fasteners can't be used, such as heat shields and support channels. Use of the Blind Fastener requires a 1/2" hole.

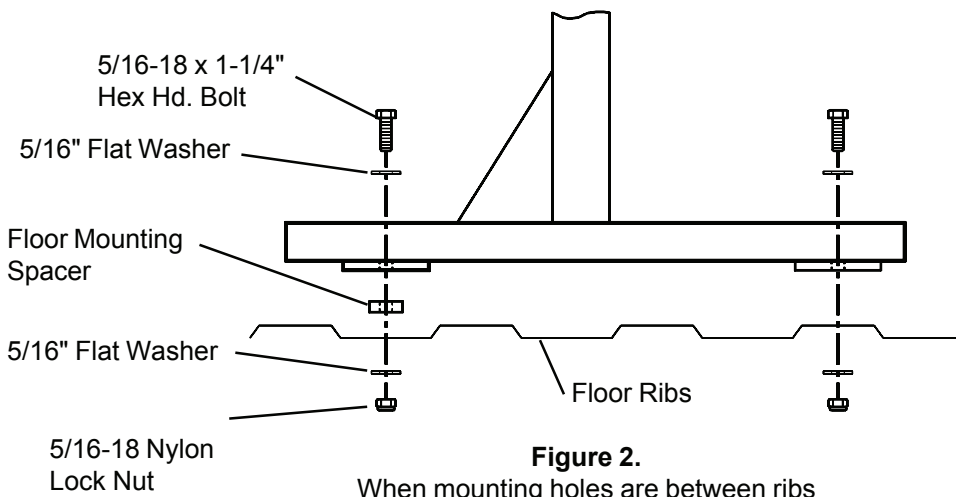

**Figure 2.**

When mounting holes are between ribs

## INSTALLATION PROCEDURE USING BLIND FASTENERS

**NOTE:** Make sure there is enough hole depth before installing the Blind Fastener, as it could damage the vehicle.

Place a drop of oil on the black oxide bolt before assembling as shown on right. Place the Blind Fastener in the hole and use a 1/2" or 7/16" wrench to tighten black hex bolt until the blind fastener is fully seated. When setting black hex bolt, it will start out hard. As the Blind Fastener "bulbs" out it will get easier, until it bottoms out or sets. Make sure the Blind Fastener and Installation Tool do not turn during installation.

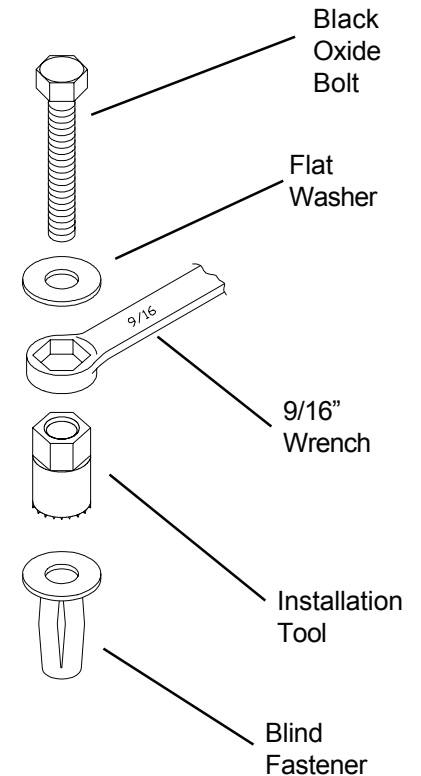

### - NOTICE -

Any modification or unintended use of this product shall immediately void all manufacturers warranties. Manufacturer disclaims all liability for injuries to persons or property resulting from any modification to, or unintended use of this product.

 **DANGER**

Danger of explosion. Do not use this product for storing or transporting flammables, explosives, hazardous materials, or hazardous waste, such as containers of gasoline, solvents, gun powder, dynamite, propane tanks, acetylene tanks and cutting torches. Failure to heed this warning will result in death or serious injury.

 **WARNING**

This product is only intended and safe for use in storing and transporting small tools, equipment and other similar materials. These instructions are to be followed using the parts and fasteners supplied for proper installation. Any modifications or improper installation of this product will create a hazardous condition that could result in death, serious personal injury and/or property damage.

All floor mounting bolts near the fuel tank area should be installed from the underside of the vehicle, to guard against the fuel tank being punctured in the event of a collision. This would mean not using Blind Fasteners in this area. Holes in this area should be 5/16". Ensure ample space in roof ribs and sidewall ribs for mounting screws so as not to puncture exterior roof or wall.

Do not install this product where it could interfere with deployment of air bags. Failure to comply could result in death or serious body injury.

 **CAUTION**

Prior to drilling, so as not to cut electric wires, fuel lines, brake lines, etc., check behind and underneath drilling and mounting locations. To keep debris out of your eyes when checking the underside of the vehicle, or when drilling, always wear protective eye wear. Failure to heed this warning will result in death or serious injury.

**– NOTICE –**

Any modification or unintended use of this product shall immediately void all manufacturers warranties. Manufacturer disclaims all liability for injuries to persons or property resulting from any modification to, or unintended use of this product.

