



VAN STORAGE SOLUTIONS
FOR THE WAY YOU WORK™

INSTALLATION MANUAL

BULKHEAD HINGE KIT

ATTENTION: PLEASE READ AND UNDERSTAND ALL INSTRUCTIONS AND WARNINGS BEFORE ASSEMBLING, INSTALLING OR USING THIS PRODUCT.

! PLAN YOUR VAN (TIPS FOR FASTER INSTALLATION)

- Installing your WEATHER GUARD® Bulkhead is very clear cut following these instructions.
- Before cutting or drilling in the floor, verify the location of you gas tank, fuel lines and electrical cables so you don't accidentally cut something important.
- Make sure that the blind fasteners go directly into the sheet-metal floor and not through a floor mat. Cut clearance holes for fasteners and spacers. Always wear eye protection when drilling or cutting.

INSTALLATION TIME

Approximate installation time: 15 minutes per unit depending on van equipment installation experience.

TOOLS REQUIRED

- Phillips Head Screwdriver
- 3/8" Ratchet Drive
- Sockets: 5/16", 11/32", 7/16"
- Open End Wrenchs: 11/32", 3/8"

PARTS LIST

Part	Quantity	Description
A	1	Door Handle Assembly
B	2	Hinges
C	1	9" Weatherstripping
D	1	Bolt Kit

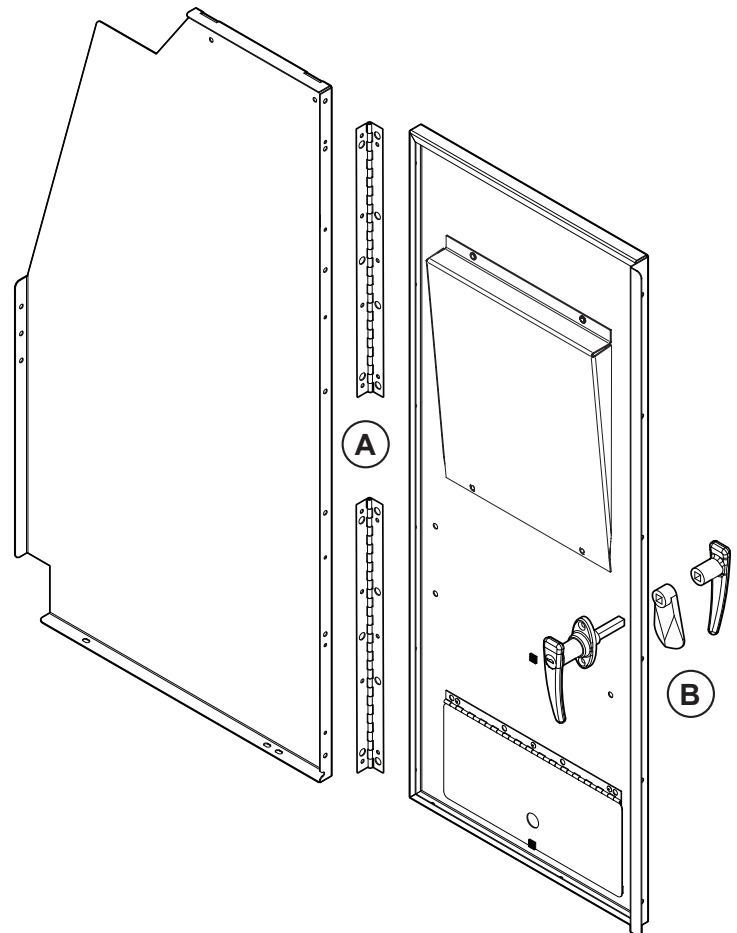

INSTALLATION INSTRUCTIONS

STEP 1: Attach Hinges to Driver Side Panel using six (6) #8-32 x 1/2" Machine Screws and #8-32 Nylon Lock Nuts from the bolt kit supplied.

NOTE: Not all mounting holes will be used on the vertical sides of either of the panels. Extra mounting holes are for the non-swing door option for this Bulkhead.

STEP 2: Attach Center Door Panel to Hinge/Driver Panel using eight (8) #8-32 x 1/2" Machine Screws and #8-32 Nylon Lock Nuts from the bolt kit supplied with the 86555 Hinge Kit.

NOTE: The tops of the Driver Side Panel and the Center Door Panel should be even (flush) and the bottoms will be uneven.

STEP 3: Cut Weatherstripping into three (3) 3" sections. Remove adhesive backing and affix to channel at top, bottom and above door latch cut-out on driver's side of door.

NOTE: Not all mounting holes will be used on the vertical sides of either of the panels. Extra mounting holes are for the non-swing door option available for this Bulkhead.

STEP 4: Attach the Door Handle Assembly to the Center Panel by passing the Locking Handle through the opening in the Center Panel. Attach the Cam Paddle and the Non-Locking Handle on the other side of the Center Panel. Using two (2) 10-24 x 3/4" Machine Screws and 10-24 Nylon Lock Nuts (from the bolt kit supplied with the 86555 Hinge Kit).

STEP 5: Adjust Cam on Handle Assembly so it rests on the rear edge of the slot in the Passenger Side Panel. In this position, tighten the Allen Head Set Screw with the Allen wrench provided.

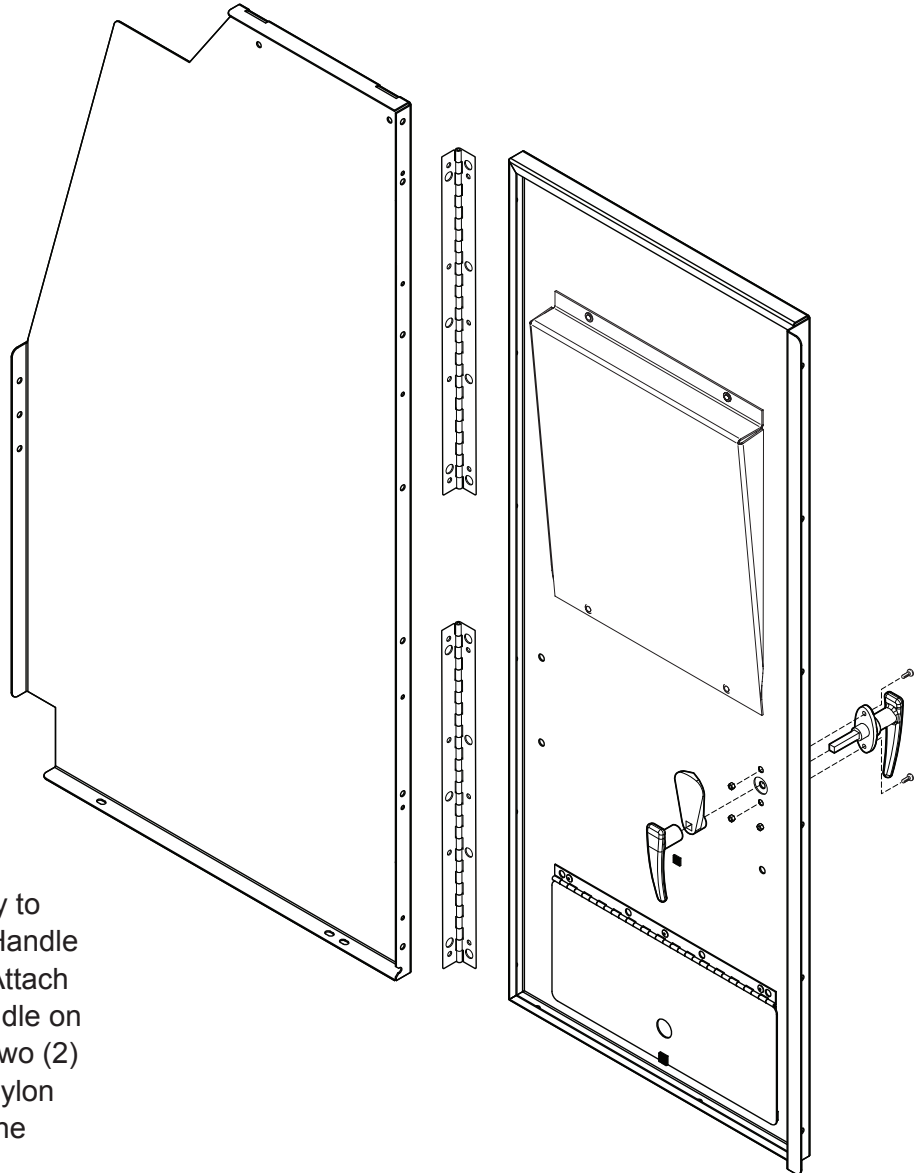

 **WARNING**

This product can reduce the driver's ability to clearly see roadways, vehicular or pedestrian traffic and other objects through the rear and side windows of the vehicle, which can cause an accident. Extra precautions should be taken when driving a vehicle with this product. Make all adjustments necessary to ensure maximum visibility, including but not limited to, changing mirror and seating positions. State and local laws may prohibit obstruction of windows in a moving vehicle.

These instructions are to be followed using the parts and fasteners supplied for proper installation. Any modifications or improper installation of this product will create a hazardous condition that could result in death, serious personal injury and/or property damage.

 **CAUTION**

Prior to drilling, so as not to cut electric wires, fuel lines, brake lines, etc., check behind and underneath drilling and mounting locations. To keep debris out of your eyes when checking the underside of the vehicle, or when drilling, always wear protective eye wear. Failure to heed this warning will result in death or serious injury.

– NOTICE –

Any modification or unintended use of this product shall immediately void all manufacturers warranties. Manufacturer disclaims all liability for injuries to persons or property resulting from any modification to, or unintended use of this product.

