



VAN STORAGE SOLUTIONS

FOR THE WAY YOU WORK™

INSTALLATION MANUAL

BULKHEAD

Model Number 96101-3-01

ATTENTION: PLEASE READ AND UNDERSTAND ALL INSTRUCTIONS AND WARNINGS BEFORE ASSEMBLING, INSTALLING OR USING THIS PRODUCT.

! PLAN YOUR VAN (TIPS FOR FASTER INSTALLATION)

- Installing your WEATHER GUARD® Bulkhead is very clear cut following these instructions.
- Before cutting or drilling in the floor, verify the location of you gas tank, fuel lines and electrical cables so you don't accidentally cut something important.
- Make sure that the blind fasteners go directly into the sheet-metal floor and not through a floor mat. Cut clearance holes for fasteners and spacers. Always wear eye protection when drilling or cutting.
- Your WEATHER GUARD® Bulkhead can be up-graded with a swing-door conversion kit, 96901-3-01. If you think you might want to change to it in the future, put an extra nut between the driver's side panel and the center panel to allow enough space.
- Mount the upper corners of the bulkhead as close to the van inside walls as possible for a sturdy and quiet installation.

BOLT KIT

DESCRIPTION	QTY.
1/4-20 Blind Fasteners	6
1/4-20 x 5/8" Hex Head Bolts	25
1/4-14 x 3/4" Self-Drilling Screws	4
1/4-20 Nylon Lock Nuts	23
1/4-20 x 1-1/4" Hex Head Bolts	4
1/4" Flat Washers	7
Floor Mounting Spacers	5
Blind Fastener Installation Tool	1
1/4-20 x 2-1/4" Hex Head Black Bolt	1
1/8" x 1" x 4" Foam Pads	2

INSTALLATION TIME

Approximate installation time: 60 minutes per unit depending on van equipment installation experience.

TOOLS REQUIRED

- Electric Drill
- 1" Hole Saw
- 5/16" Nut Driver Bit
- Pencil or Marker
- Hammer
- Center Punch
- Drill Bits: 1/8", 5/16", 13/32"
- 3/8" Ratchet Drive
- Sockets: 5/16", 7/16"
- Level
- Carpenter's Square
- Open End Wrenches: 7/16", 9/16"

PARTS LIST

	Qty.	Description
A	1	Passenger Side Panel
B	1	Driver Side Panel
C	1	Center Panel
D	1	Door Pocket
E	2	Roof Mount Brackets
F	1	Driver Side Attachment Brackets
G	1	Passenger Side Panel Reinforcement Bracket

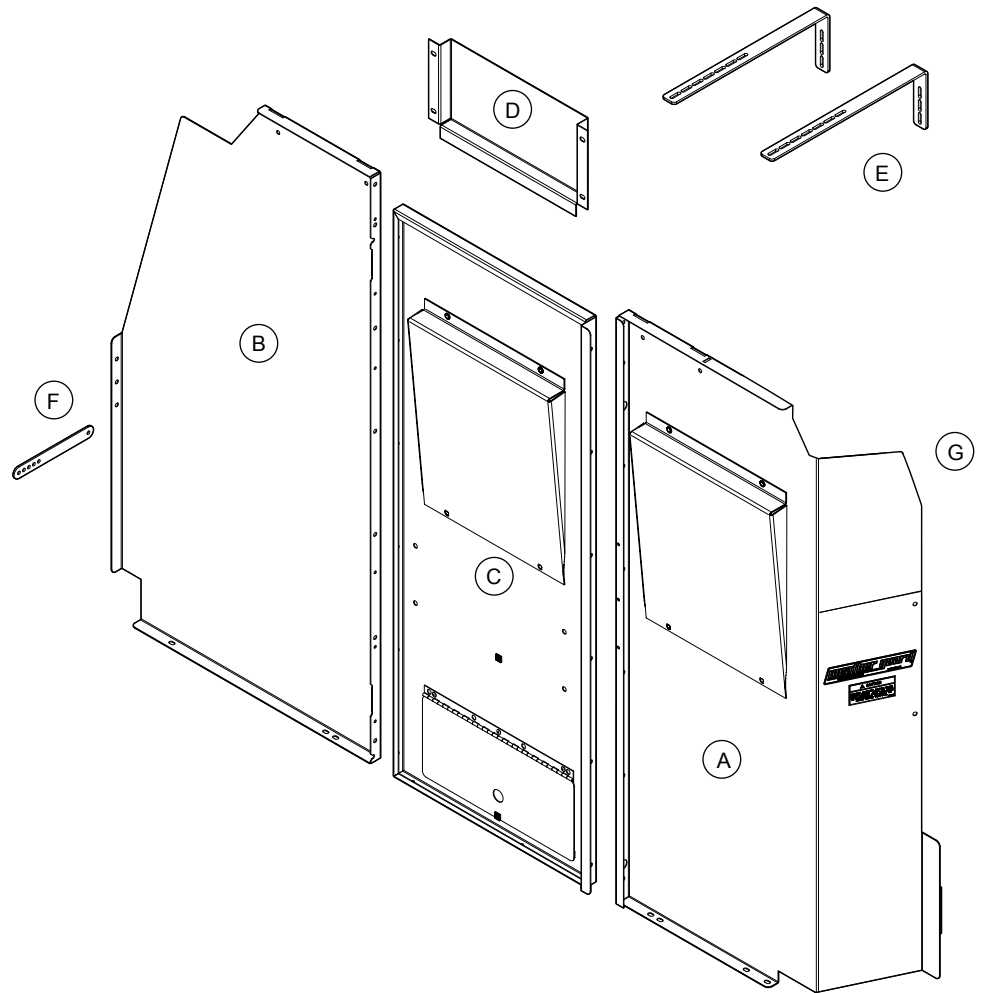

INSTALLATION INSTRUCTIONS

STEP 1: Assemble the Door Pocket to the driver's side of the Center Panel using four (4) 1/4-20 x 5/8" Hex Head Bolts, 1/4-20 Nylon Lock Nuts and 1/4" Flat Washers. Nuts could be used on the cargo side.

NOTE: The hinged door will remain open or closed by connecting the small squares of hook and loop material on the door to the small squares on the center panel in either position.

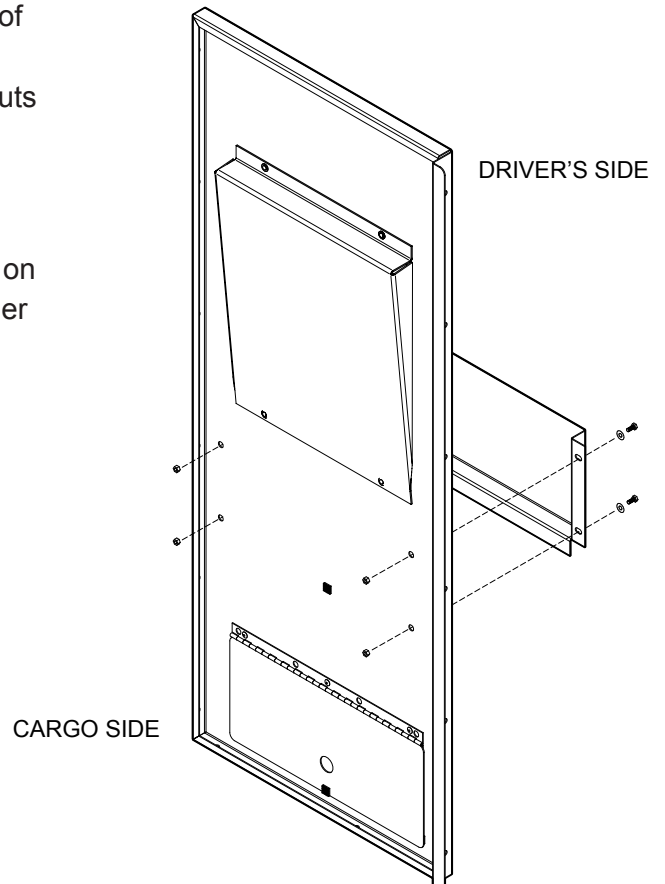
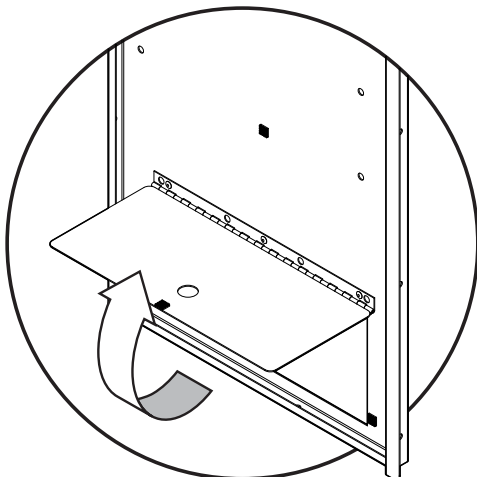

INSTALLATION INSTRUCTIONS

STEP 2: Attach Driver Side Panel to Center Panel with both panels flush at the bottom using six (6) 1/4-20 x 5/8" Hex Head Bolts and 1/4-20 Nylon Lock Nuts.

NOTE: Not all mounting holes will be used on the vertical sides of either panel. Extra mounting holes are for the swing door option available for this Bulkhead.

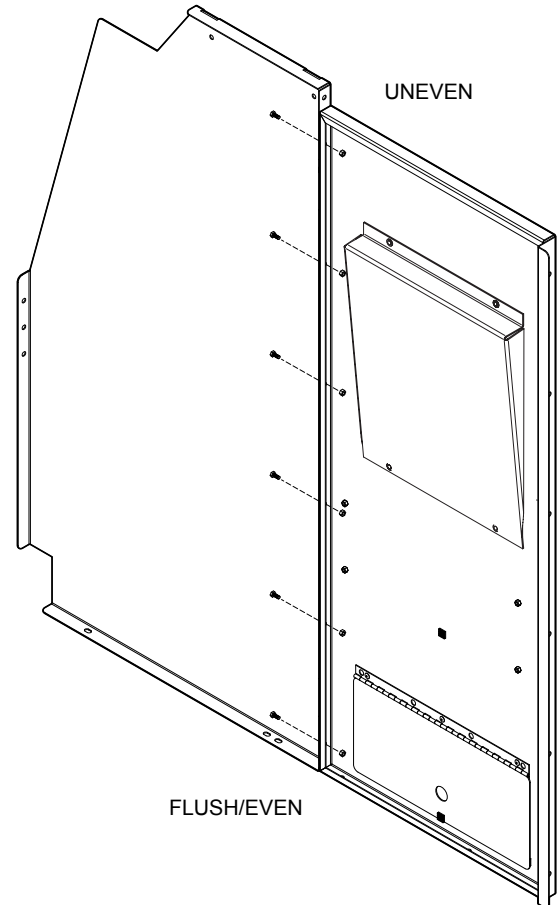

STEP 3: Attach the Passenger Side Panel to Center Panel using six (6) 1/4-20 x 5/8" Hex Head Bolts and 1/4-20 Nylon Lock Nuts. With the help of a second person, place assembled Bulkhead inside the van in the approximate mounting location.

NOTE: Not all mounting holes will be used on the vertical sides of either panel. Extra mounting holes are for the swing door option available for this Bulkhead.

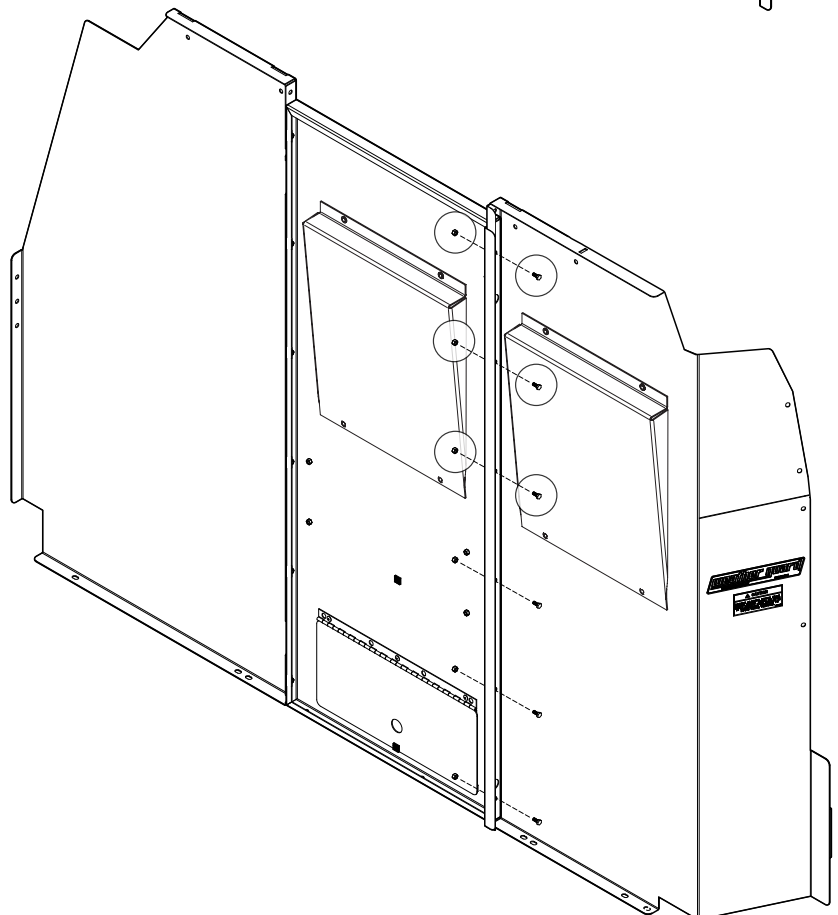

INSTALLATION INSTRUCTIONS

STEP 4: Tilt assembled Bulkhead away from van roof and slide in two (2) Roof Mount Brackets to Bulkhead. Using two (2) 1/4-20 x 5/8" Hex Head Bolts, 1/4-20 Nylon Lock Nuts and 1/4" Flat Washers, attach brackets to panels. Leave fasteners loose for easier adjustment during final installation.

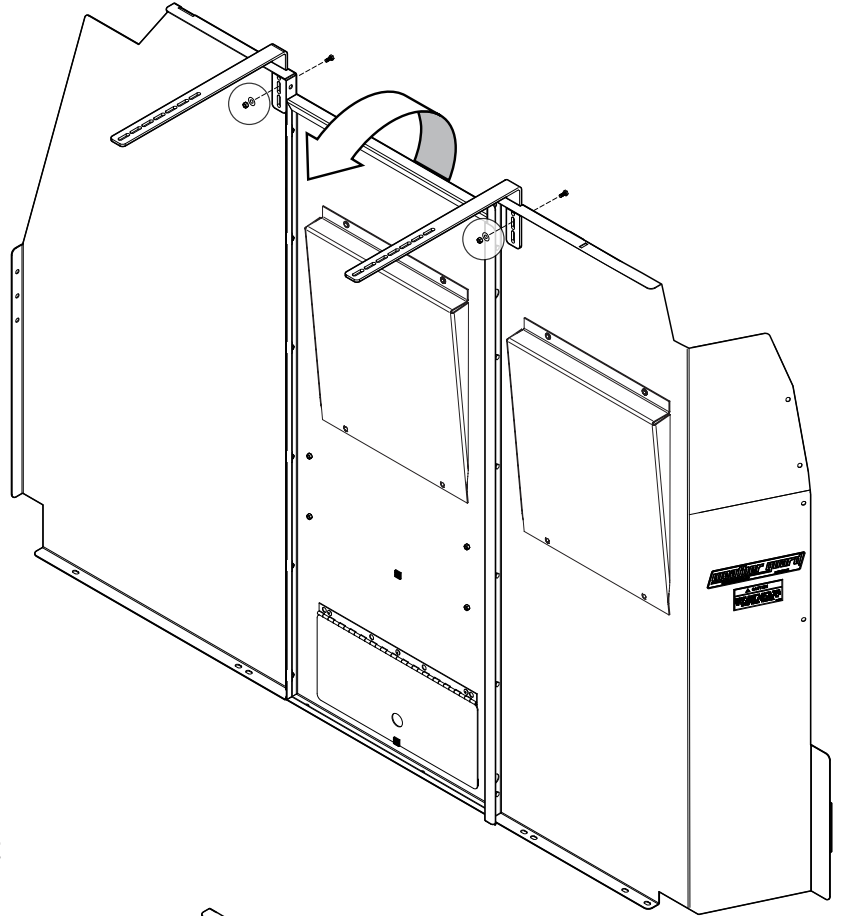

STEP 5: Attach the Driver Side Attachment Brackets to Driver Side Panel using 1/4-20 x 5/8" Hex Head Bolt and 1/4-20 Nylon Lock Nut.

NOTE: Use holes that best align with wall or wall rib for your van model.

Attach the 1x4 Foam Pads to the Bulkhead where they come in contact with the lower B-Pillar.

Assemble two mounting steps by attaching a mounting strap to a mounting angle with a 1/4-20x 3/4" washer head bolt and a lock nut. Mount one strap to the driver's side and passenger's side panels.

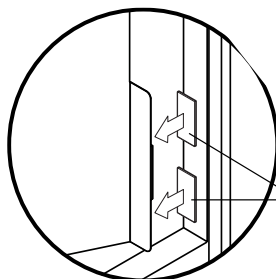
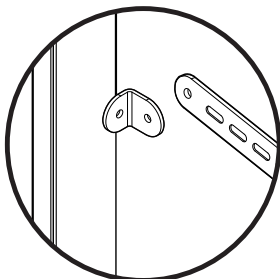
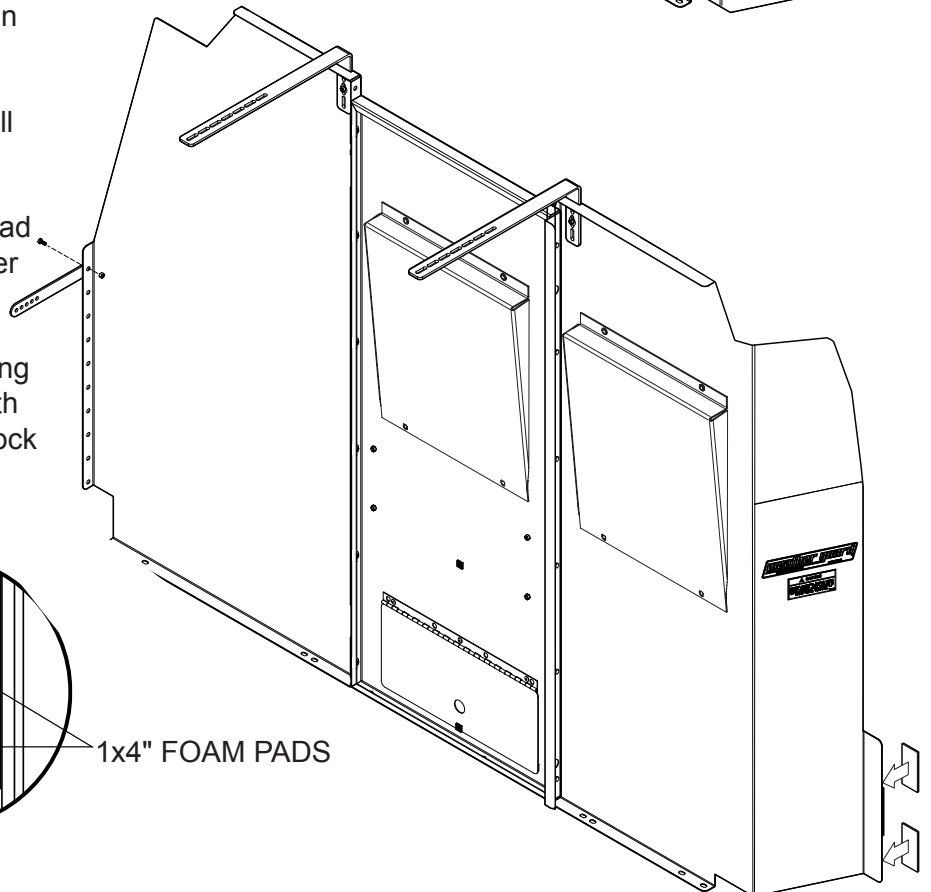

1x4" FOAM PADS

INSTALLATION INSTRUCTIONS

STEP 6: Position assembled Bulkhead in place ensuring that it is vertically level. Using a level or carpenter's square, square the Bulkhead to the floor and mark hole locations for:

- Driver Side Attachment Brackets (where brackets meet wall rib)
- Roof Mount Brackets (where brackets meet roof rib)
- B-Pillar Attachment Bracket along the floor on top of floor ribs.

Once all holes are marked, move assembly out of position, giving yourself ample room to work on the floor hole locations.

NOTE: If van has roof liner, look for plastic rivets installed into ceiling rib, using an awl, test for rib location and mark where the Roof Mount Brackets align with the roof rib.

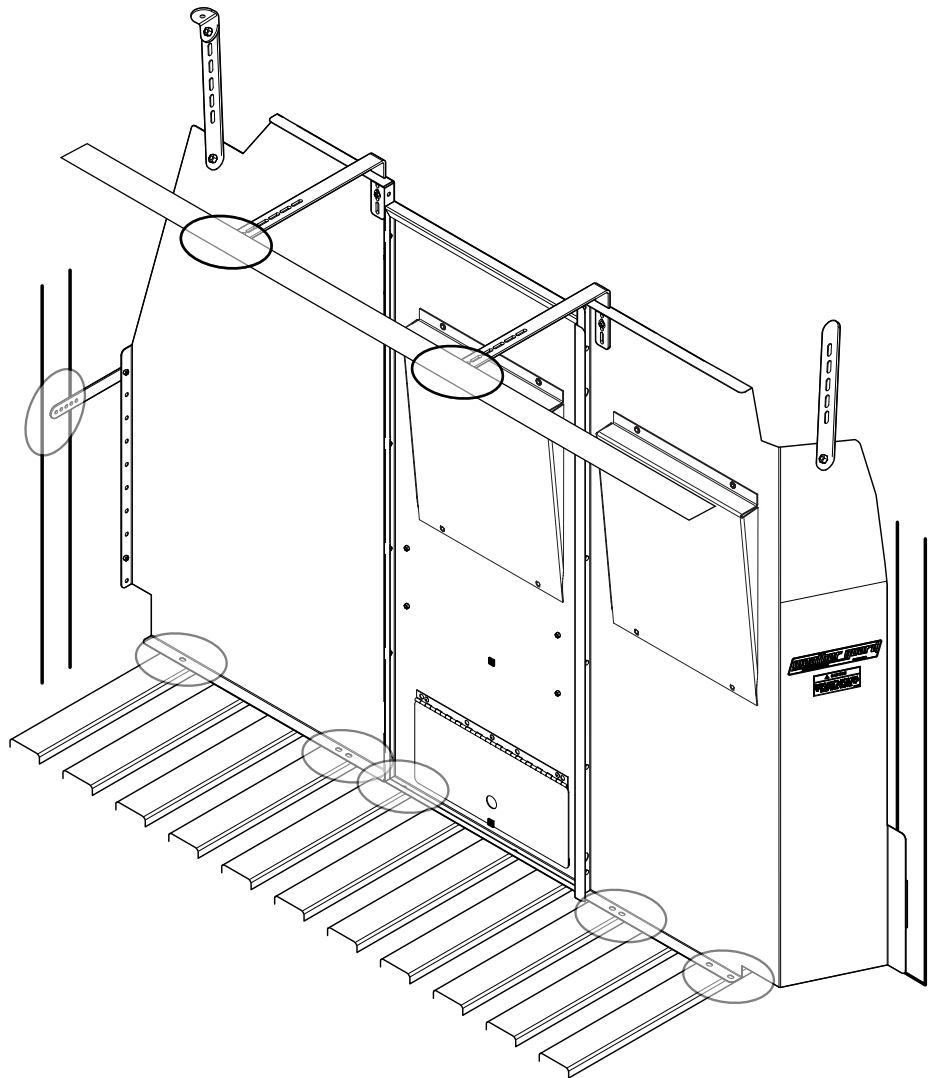

STEP 7: Pre-drill the floor mounting locations with an 1/8" drill bit, then re-drill the hole with a 5/16" drill bit. If there is a floor mat, then Floor Mounting Spacers are required. Cut the floor mat around the 5/16" holes with the 1" hole saw, allowing Floor Mounting Spacers to rest against the metal floor. **DO NOT DRILL THROUGH THE VAN FLOOR WITH THE HOLE SAW.**

Move the assembled Bulkhead back into position. Fasten Bulkhead to van floor using five (5) 1/4-20 x 1-1/4" Hex Head Bolts, 1/4" Flat Washers, Floor Mounting Spacers (if applicable), second set of 1/4" Flat Washers and 1/4-20 Nylon Lock Nuts. (See example bolting solutions below).

NOTE: See INSTALLATION INSTRUCTIONS FOR BLIND FASTENERS on page 7.

INSTALLATION INSTRUCTIONS

NOTE: The floor bolting solution could be a variation on any of these three examples with or without the floor mat.

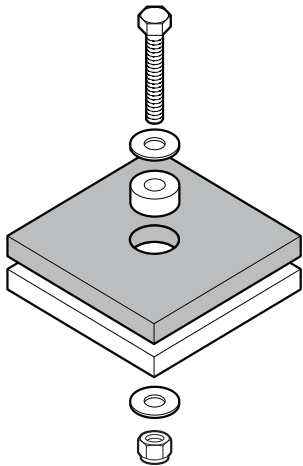

TOP DOWN INSTALLATION
THROUGH FLOOR MAT
AND VAN FLOOR

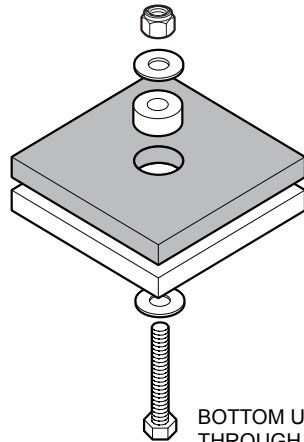

BOTTOM UP INSTALLATION
THROUGH FLOOR MAT
AND VAN FLOOR

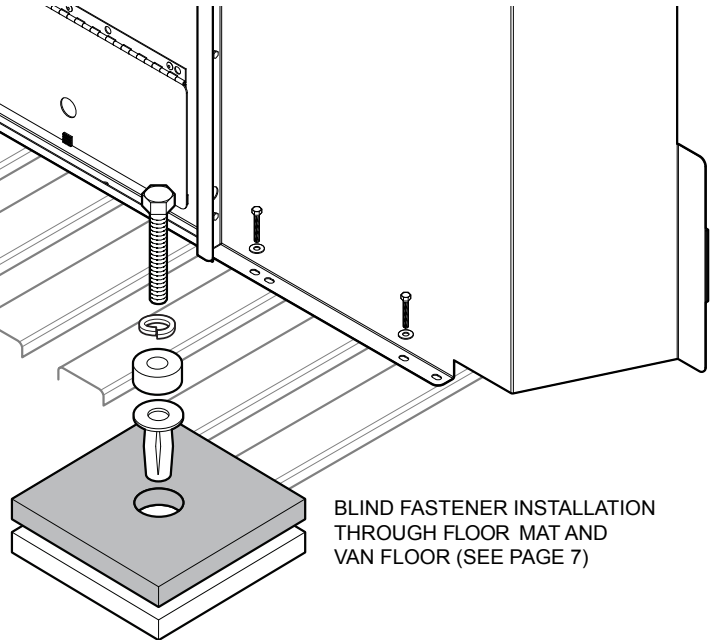

STEP 8: Realign the Driver Side Attachment Brackets on top of the Blind Fasteners and secure them to the wall or wall rib using two (2) 1/4-20 x 3/4" Self-drilling screws and 1/4" Lock Washers.

Tighten all fasteners that were left loose in Step 4.

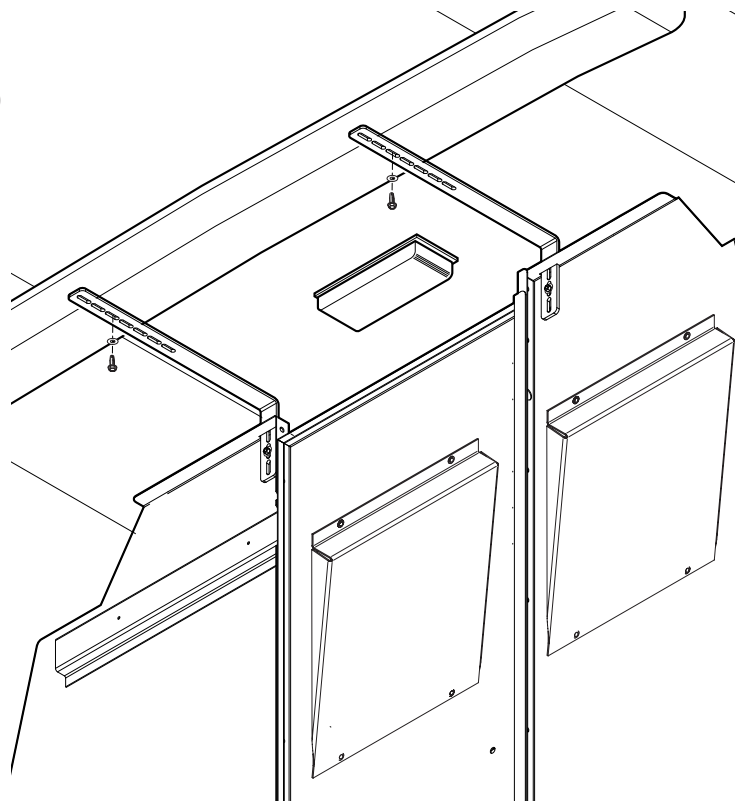
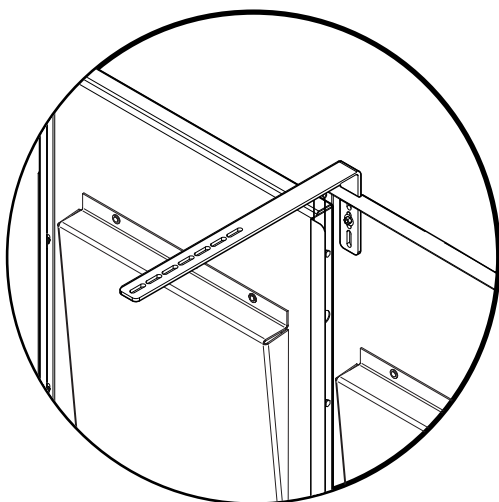

INSTALLATION INSTRUCTIONS

STEP 9: Install two (2) Blind Fasteners in the wall or wall rib at the Driver Side Attachment Bracket locations by pre-drilling 1/8" holes and then re-drill the holes with a 13/32" drill bit. Set the Blind Fasteners in the holes per the INSTALLATION INSTRUCTIONS FOR BLIND FASTENERS below.

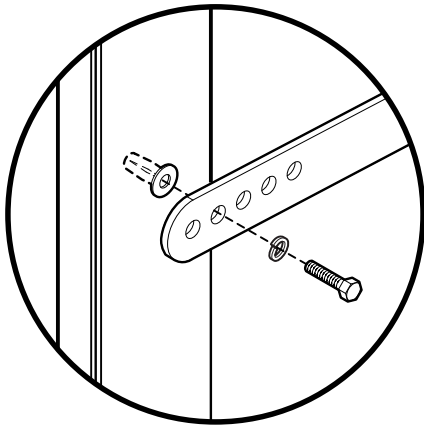

Realign the Roof Mount Brackets to their marked locations and fasten them to the roof rib using four (4) 1/4-14 x 3/4" Self-Drilling Screws and 1/4" Flat Washers. Tighten all fasteners that were left loose in Step 4.

WALL OR
WALL RIB

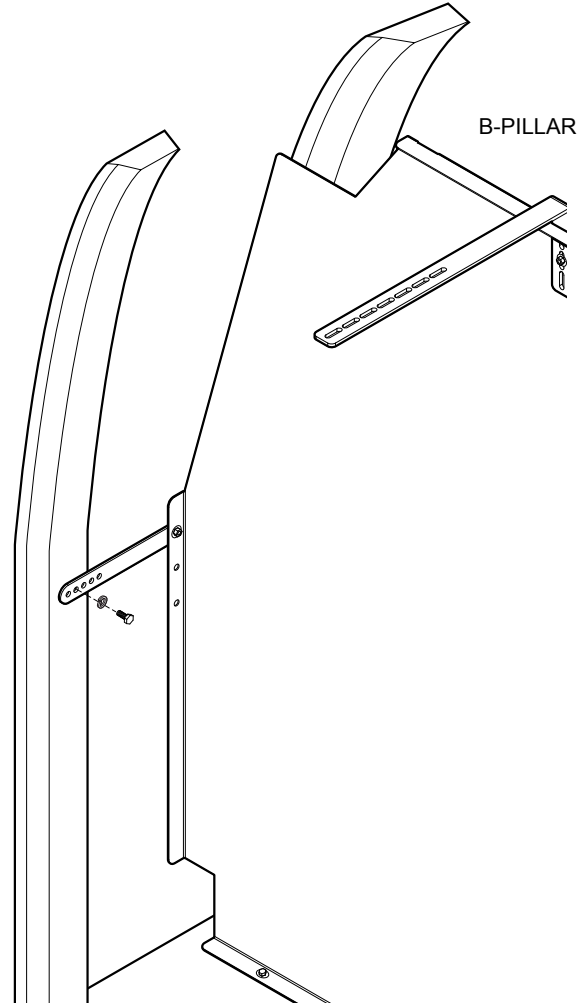

INSTALLATION IS COMPLETE.

INSTALLATION INSTRUCTIONS FOR BLIND FASTENER

Place a drop of oil on the black oxide bolt before assembling as shown on right. Place the Blind Fastener in the hole and use a 7/16" wrench to tighten black hex bolt until the Blind Fastener is fully seated. When setting black hex bolt, it will start out hard. As the Blind Fastener "bulbs" out it will get easier, until it bottoms out or sets. Make sure the Blind Fastener and Installation Tool do not turn during installation.

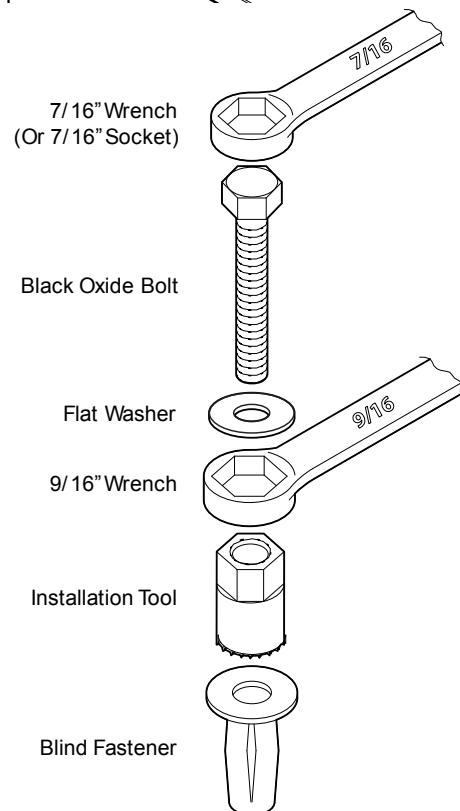

 **WARNING**

This product can reduce the driver's ability to clearly see roadways, vehicular or pedestrian traffic and other objects through the rear and side windows of the vehicle, which can cause an accident. Extra precautions should be taken when driving a vehicle with this product. Make all adjustments necessary to ensure maximum visibility, including but not limited to, changing mirror and seating positions. State and local laws may prohibit obstruction of windows in a moving vehicle.

These instructions are to be followed using the parts and fasteners supplied for proper installation. Any modifications or improper installation of this product will create a hazardous condition that could result in death, serious personal injury and/or property damage.

 **CAUTION**

Prior to drilling, so as not to cut electric wires, fuel lines, brake lines, etc., check behind and underneath drilling and mounting locations. To keep debris out of your eyes when checking the underside of the vehicle, or when drilling, always wear protective eye wear. Failure to heed this warning will result in death or serious injury.

– NOTICE –

Any modification or unintended use of this product shall immediately void all manufacturers warranties. Manufacturer disclaims all liability for injuries to persons or property resulting from any modification to, or unintended use of this product.