



VAN STORAGE SOLUTIONS
FOR THE WAY YOU WORK™

INSTALLATION MANUAL

ACCESSORY SHELF DOOR

ATTENTION: PLEASE READ AND UNDERSTAND ALL INSTRUCTIONS AND WARNINGS BEFORE ASSEMBLING, INSTALLING OR USING THIS PRODUCT.

BOLT KIT

DESCRIPTION	QTY
1/4-20 x 5/8" Hex Head Bolts	15
1/4-20 Nylon Lock Nuts	15

PARTS

Item	Qty.	Description
A	1	Latch Plate
B	2	Support Flanges

INSTALLATION TIME

Approximate installation time: 10 minutes per unit depending on van equipment installation experience.

TOOLS REQUIRED

- Ruler
- Open End Wrenches: (2) 7/16", 1/2"

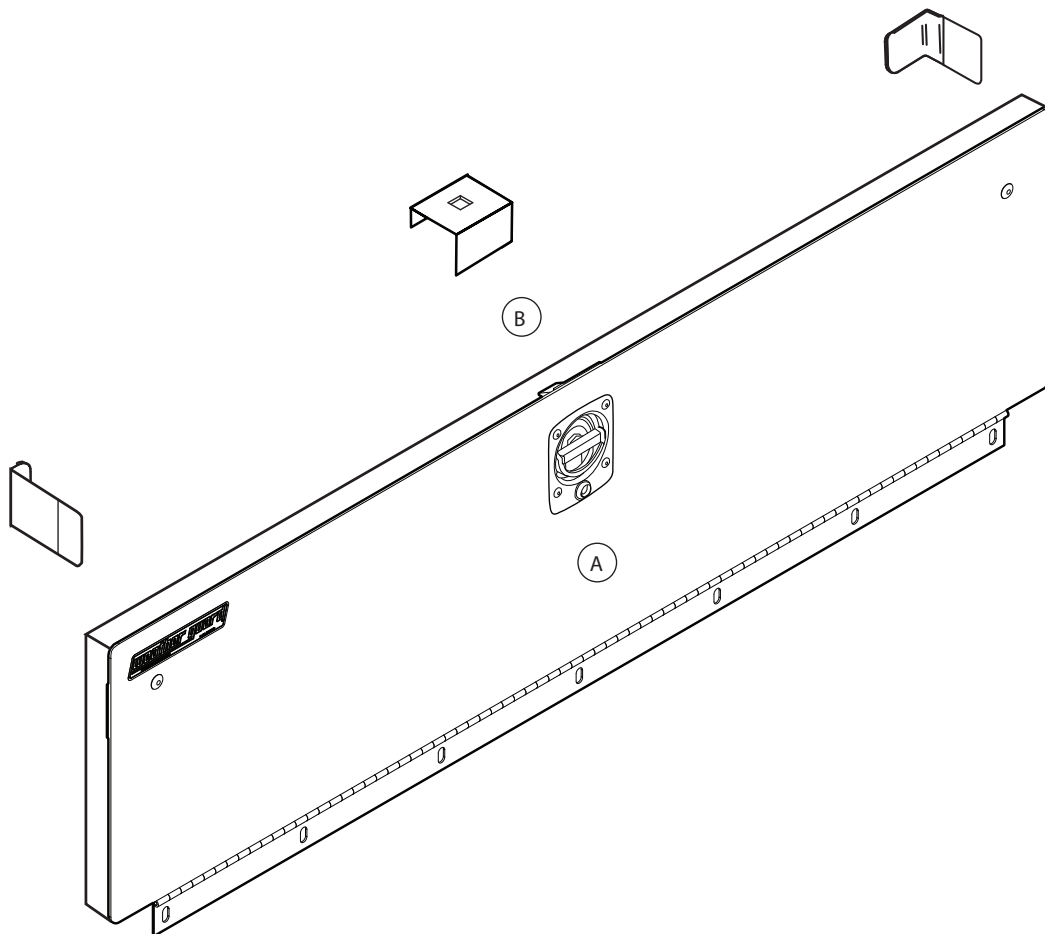

INSTALLATION INSTRUCTIONS

STEP 1: Determine Shelf Door Assembly location on Shelf Unit. Shelves need to be spaced seven (7) End Panel holes apart (bolt to bolt) for the door to fit correctly. Place Door Assembly against the opening between shelves and fasten hinge to the row of shelf holes using one (1) 1/4-20 x 5/8" Hex Head Bolts and 1/4-20 Nylon Lock Nuts per hole in hinge. The length of the Shelf Door Assembly will determine the number of fasteners used.

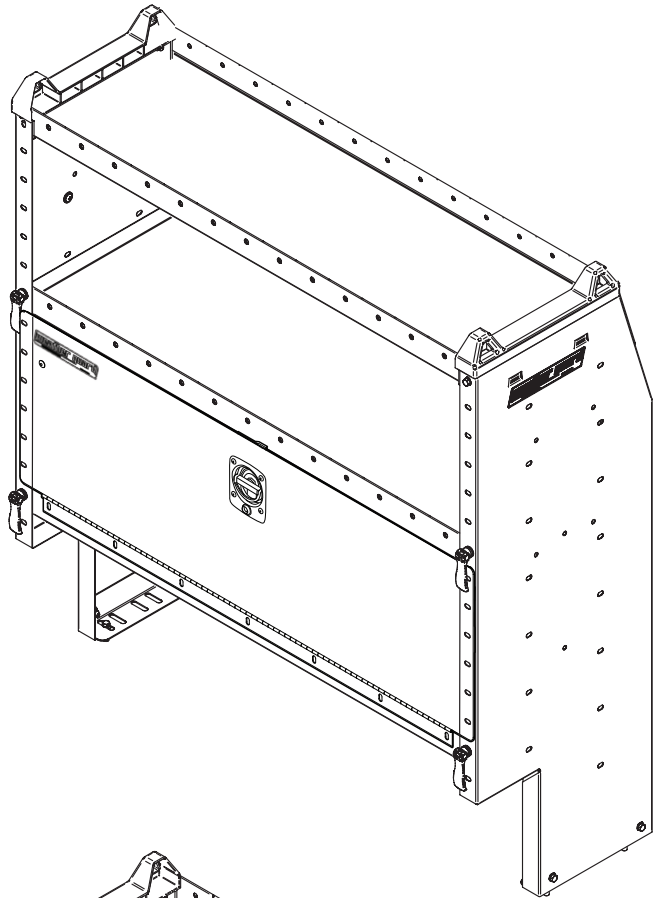

STEP 2: Fasten the Latch Plate to the bottom of the shelf using the 5/16 carriage bolt and 5/16 lock nut. Locate the latch plate as shown with the vertical tab facing the shelf door.

STEP 3: Count holes from hinge and attach the cables and support tabs to the end panels using the 1/4-20 hex head bolts and lock nuts.

STEP 4: Place a section of adhesive-backed foam to the latch plate and support tabs for a more quiet operation.

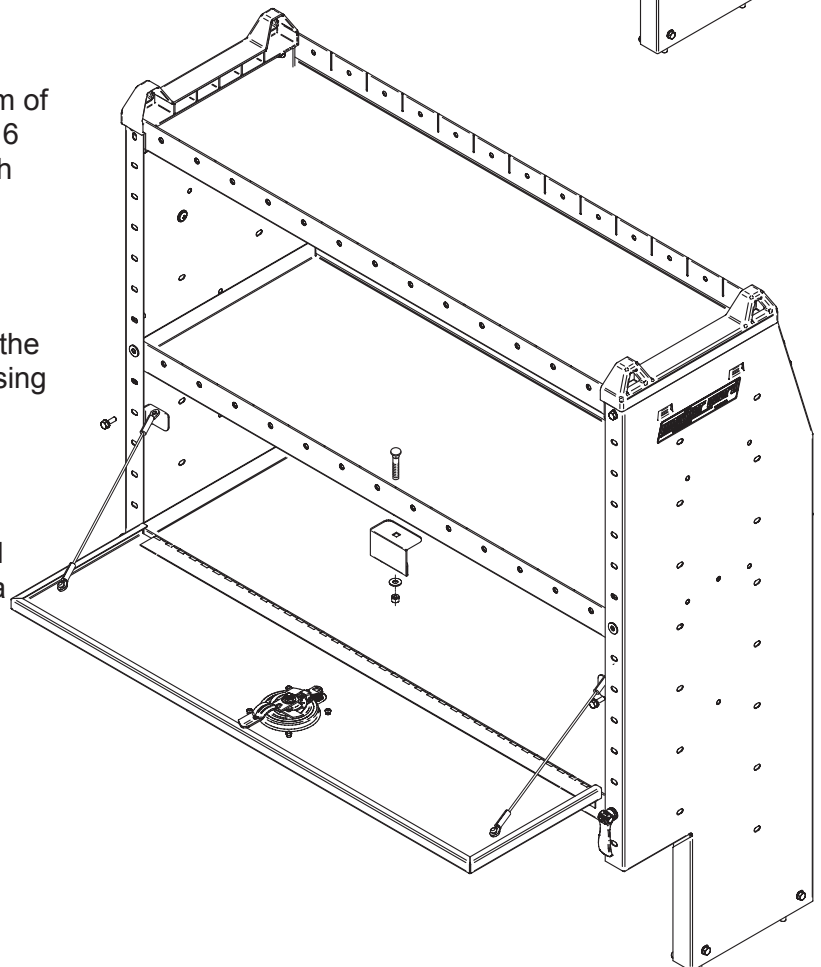

INSTALLATION IS COMPLETE.

 **WARNING**

This product is only intended and safe for use in storing and transporting small tools, equipment and other similar materials. These instructions are to be followed using the parts and fasteners supplied for proper installation. Any modifications or improper installation of this product will create a hazardous condition that could result in death, serious personal injury and/or property damage.

All floor mounting bolts near the fuel tank area should be installed from the underside of the vehicle, to guard against the fuel tank being punctured in the event of a collision. This would mean not using Blind Fasteners in this area. Holes in this area should be 5/16". Ensure ample space in roof ribs and sidewall ribs for mounting screws so as not to puncture exterior roof or wall.

 **CAUTION**

Prior to drilling, so as not to cut electric wires, fuel lines, brake lines, etc., check behind and underneath drilling and mounting locations. Failure to heed this warning will result in death or serious injury.

– NOTICE –

Any modification or unintended use of this product shall immediately void all manufacturers warranties. Manufacturer disclaims all liability for injuries to persons or property resulting from any modification to, or unintended use of this product.

