



# INSTALLATION MANUAL

## WELDED VAN SHELF MODELS 9400/9452

ATTENTION: PLEASE READ AND UNDERSTAND ALL INSTRUCTIONS AND WARNINGS BEFORE ASSEMBLING, INSTALLING OR USING THIS PRODUCT.

### DANGER

Danger of explosion. Do not use this product for storing or transporting flammables, explosives, hazardous materials, or hazardous waste, such as containers of gasoline, solvents, gun powder, dynamite, propane tanks, acetylene tanks and cutting torches. This product is only intended and safe for use in storing and transporting small tools, equipment and other similar materials. Any modifications made to, or unintended use of this product, could create a hazardous condition that can cause death, serious personal injury or property damage.

### WARNING

These instructions are to be followed using the parts and fasteners supplied for proper installation. Any modifications or improper installation of this product will create a hazardous condition that can cause property damage, serious personal injury or death.

### – NOTICE –

Any modification or unintended use of this product shall immediately void all manufacturers warranties. Manufacturer disclaims all liability for injuries to persons or property resulting from any modification to, or unintended use of this product.

**Approximate Assembly and Installation Time:**  
45 min. (.75 hours) depending on van equipment installation experience.

#### PARTS (supplied with 9400)

Item	Qty.	Description
A	1	42" Welded Shelf Unit
B	1	1-1/4" Wide Shelf Lip
C	2	Floor Mounitng Brackets



#### PARTS (supplied with 9452)

Item	Qty.	Description
A	1	51" Welded Shelf Unit
B	1	1-1/4" Wide Shelf Lip
C	2	Floor Mounitng Brackets

#### TOOLS REQUIRED

- Electric Drill
- Drill Bits: 13/32", 5/16", 1/8"
- Open End Wrenches: (2) 7/16", 9/16"
- 1" Hole Saw

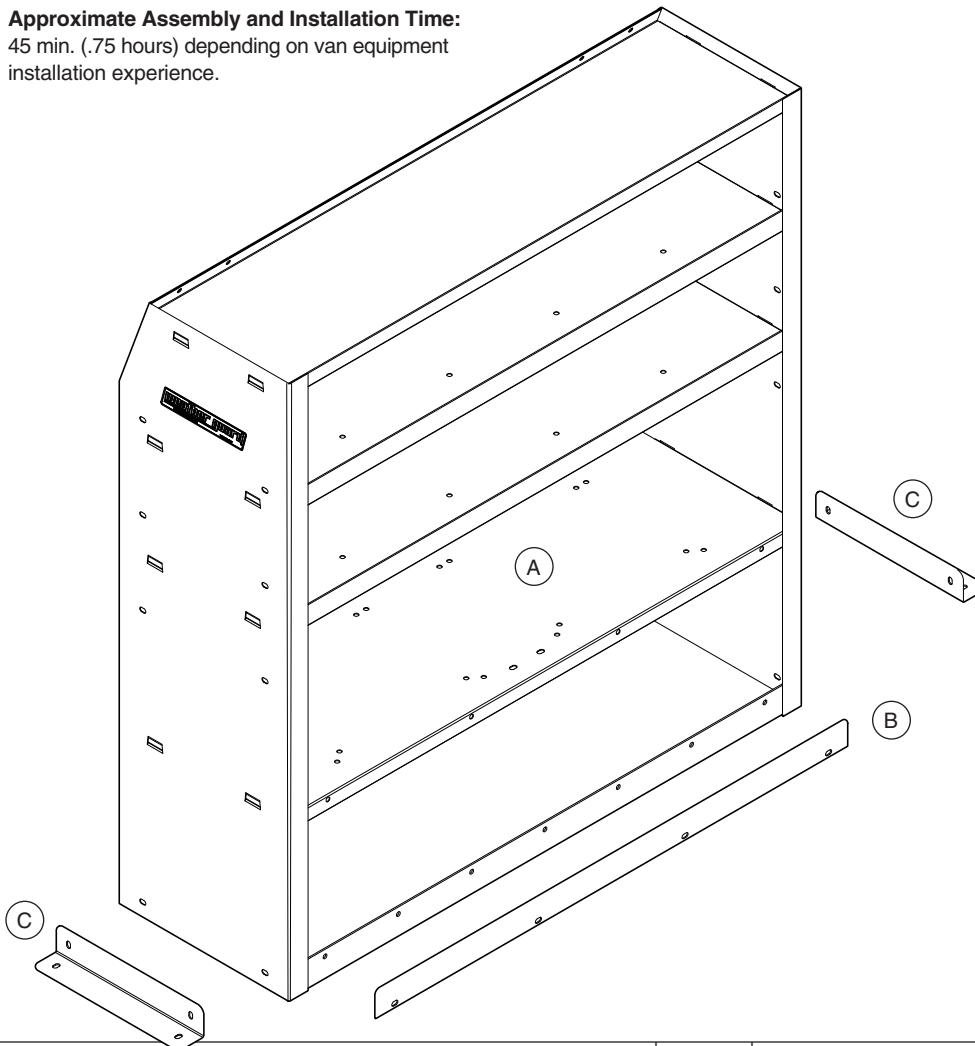

**Qty. Product**

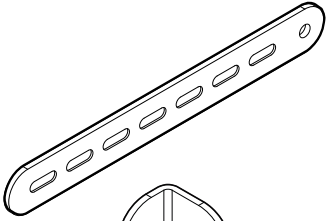

3 Mounting Straps

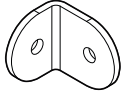

3 Mounting Strap Angles



4 1/4" Lock Washers



4 1/4-20 Blind Fasteners



7 1/4-20 x 3/4" Hex Head Screws



11 1/4-20 x 5/8" Hex Head Bolts

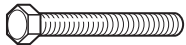

4 1/4-20 x 1-1/4" Hex Head Bolts

**Qty. Product**



22 1/4-20 Nylon Lock Nuts



19 1/4" Flat Washers



4 Floor Mounting Spacers



1 Blind Fastener Installation Tool



1 1/4-20 x 2-1/4" Hex Head Black Bolt



## CAUTION

Prior to drilling, so as not to cut or puncture fuel tanks, fuel lines, brake lines, electric wires, etc., check behind or underneath drilling and mounting locations.

To keep debris out of your eyes when checking the underside of the vehicle, or when drilling, always wear protective eyewear.



## WARNING

All floor mounting bolts near the fuel tank area should be installed from the underside of the vehicle, to guard against the fuel tank being punctured in the event of a collision. This would mean not using Blind Fasteners in this area. Holes in this area should be 5/16". Ensure ample space in roof ribs and sidewall ribs for mounting screws so as not to puncture exterior roof or wall.

- 1 Attach the Floor Mounting Brackets to both ends of the Welded Shelf using four (4) 1/4-20 x 3/4" Hex Head Bolts, 1/4" Flat Washers and 1/4-20 Nylon Lock Nuts.

NOTE: Floor Mounting Brackets can be installed on the outside or inside ends of the Welded Shelf. When installing two Welded Shelves side by side or connected to a Bulkhead, only one Floor Mounting Bracket is required and should be installed inside.

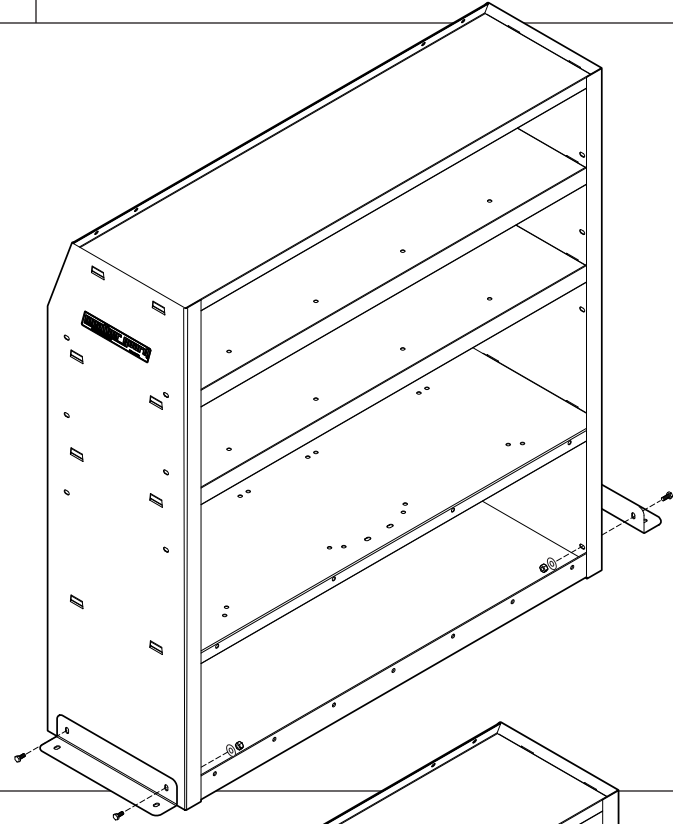
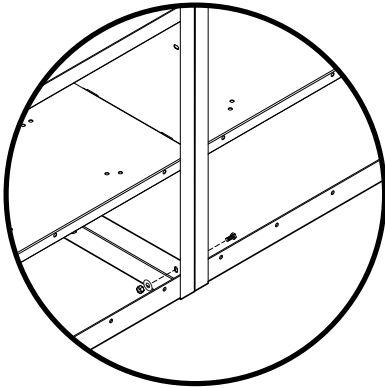

- 2 Fasten the lower Shelf Lip to the Welded Shelf using four (4) 1/4-20 x 5/8" Hex Head Bolts and 1/4-20 Nylon Lock Nuts.

Place the Welded Shelf into your selected position in the van, as close to the wall as possible. Mark the four floor mounting holes.

Remove the Welded Shelf and pre-drill the floor mounting locations with an 1/8" drill bit, then re-drill the hole with a 5/16" drill bit. If there is a floor mat, then Floor Mounting Spacers are required. Cut the floor mat around the 5/16" holes with the 1" hole saw, allowing Floor Mounting Spacers to rest against the metal floor. **DO NOT DRILL THROUGH THE VAN FLOOR WITH THE HOLE SAW.**

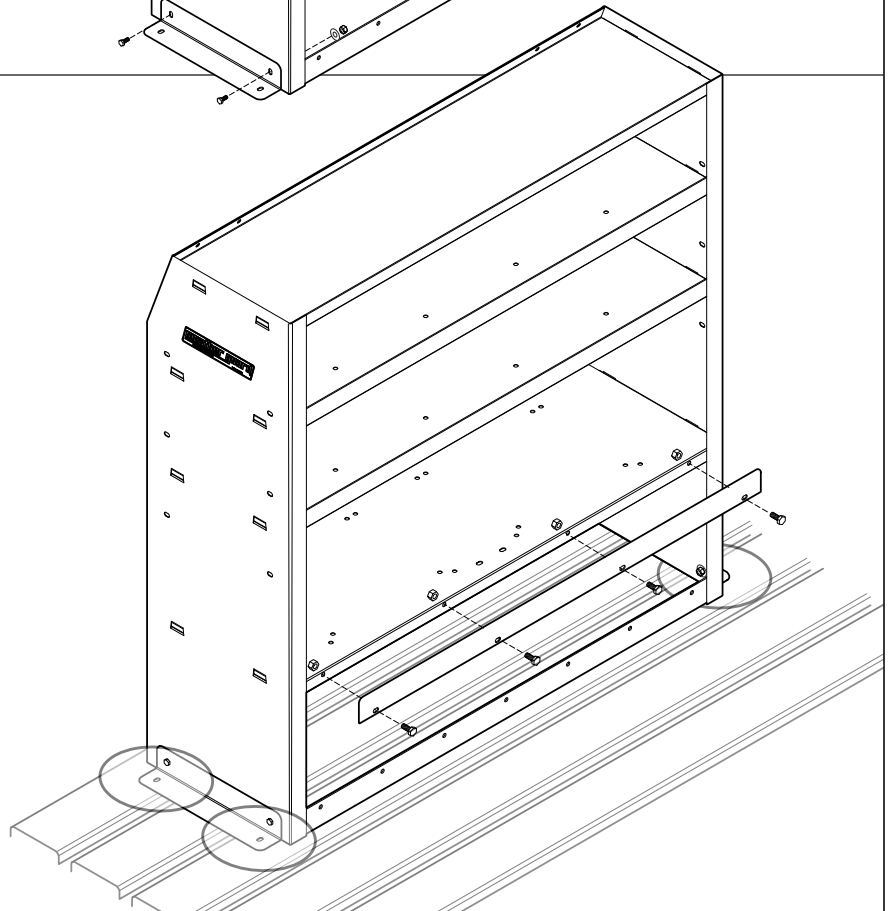

- 3 Move the Shelf back into position. Fasten Shelf to van floor using four (4) 1/4-20 x 1-1/4" Hex Head Bolts, 1/4" Flat Washers, Floor Mounting Spacers (if applicable), second set of 1/4" Flat Washers and 1/4-20 Nylon Lock Nuts. (See example bolting solutions below).

**NOTE:** One (1) Blind Fastener and Lock Washer have been provided in case through-bolting is impossible due to heat shields, floor channels, fuel lines, etc. If Blind Fastener installation is necessary, re-drill the 5/16" mounting holes with 13/32" drill bit. See INSTALLATION INSTRUCTIONS FOR BLIND FASTENERS on page 5.

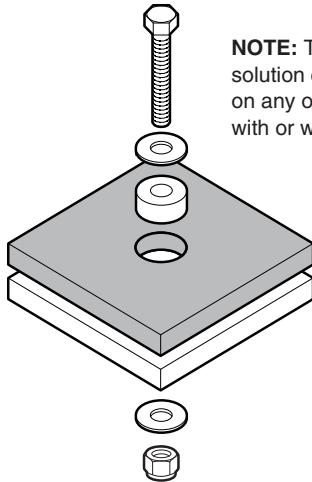
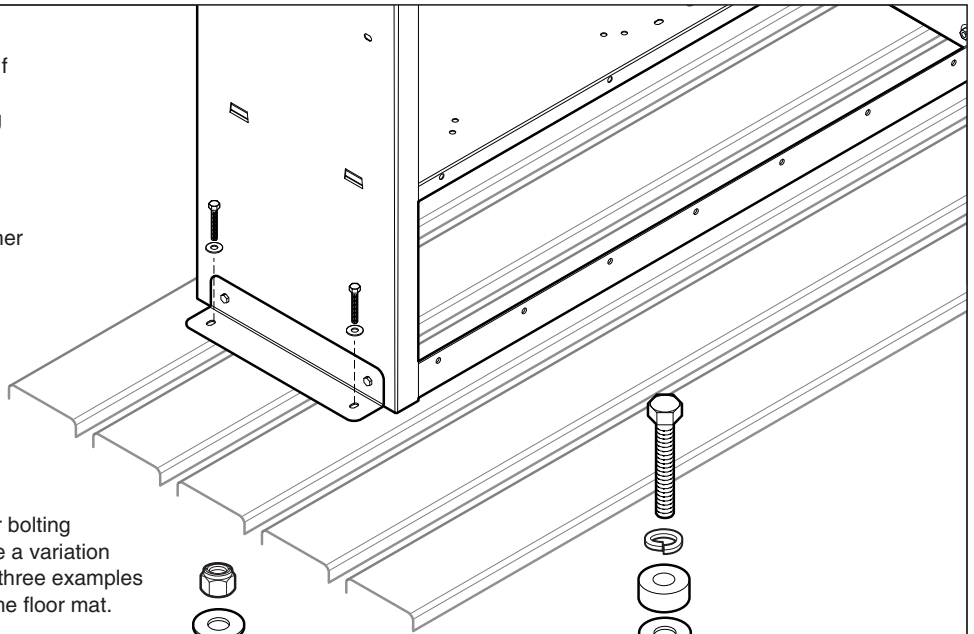

**NOTE:** The floor bolting solution could be a variation on any of these three examples with or without the floor mat.

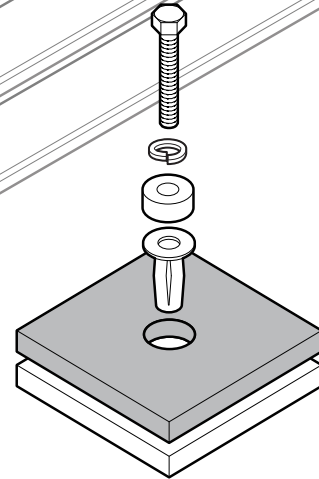
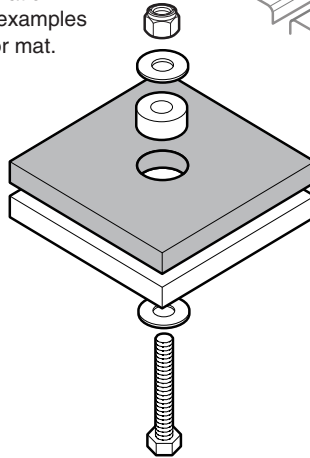

TOP DOWN INSTALLATION THROUGH FLOOR MAT AND VAN FLOOR

BOTTOM UP INSTALLATION THROUGH FLOOR MAT AND VAN FLOOR

BLIND FASTENER INSTALLATION THROUGH FLOOR MAT AND VAN FLOOR (SEE PAGE 5)

- 4 Three (3) Mounting Straps and Mounting Strap Angles are provided. The Mounting Straps can be bent to any shape and/or used with the Mounting Angles. The Mounting Straps should be attached to the upper portion of the Welded Shelf in a manner that would minimize movement of the unit both front to rear and side to side. Attach the Mounting Straps to the Welded Shelf through existing holes (or drill new holes using a 5/16" drill bit) and fasten with three (3) 1/4-20 x 5/8" Hex Head Bolts and 1/4-20 Nylon Lock Nuts.

Fasten the other end of the Mounting Straps by installing two to three (2-3) Blind Fasteners in the wall or wall ribs at the Mounting Strap locations by pre-drilling 1/8" holes and then re-drill the holes with a 13/32" drill bit. Set the Blind Fasteners in the holes per the INSTALLATION INSTRUCTIONS FOR BLIND FASTENERS on page 5.

Realign the Mounting Straps/Mounting Strap Angles on top of the Blind Fasteners and secure them to the wall or wall rib using two to three (2-3) 1/4-20 x 3/4" Hex Head Bolts and 1/4" Lock Washers.

**INSTALLATION IS COMPLETE.**

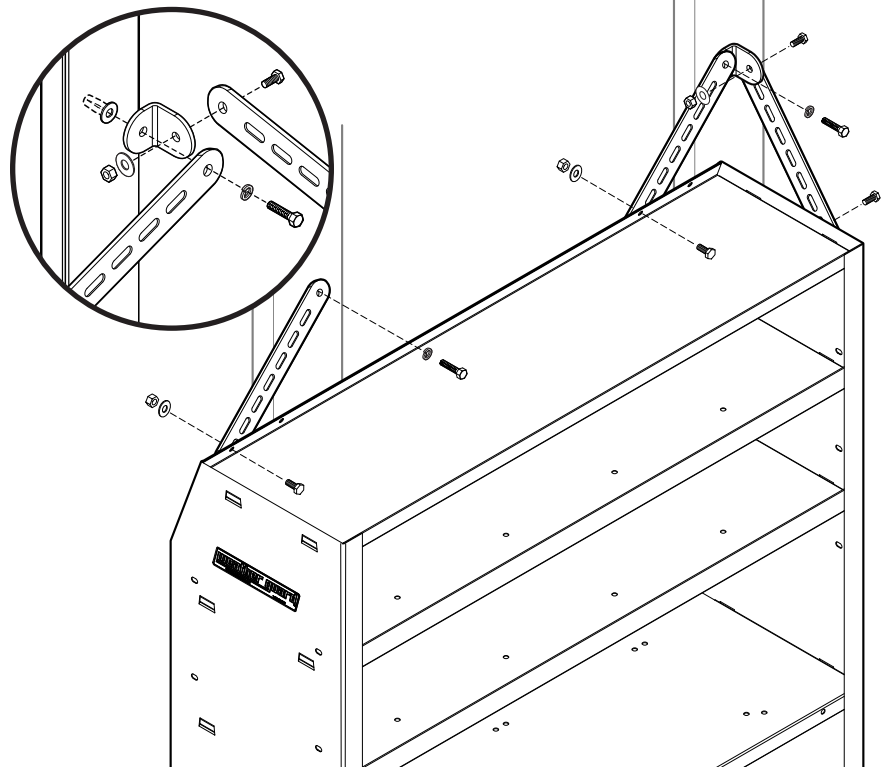

- 5 If you purchased 8401 or 8402 Shelf Dividers, install each Divider with two (2) 1/4-20 x 5/8" Hex Head Bolts and 1/4-20 Nylon Lock Nuts installed through the underside of the shelf.

**NOTE:** The side panels of the units have pre-punched holes conveniently located for installation of accessory items or to fasten to other shelf units for additional strength. Extra 1/4-20 x 5/8" bolts and lock nuts have been provided in the bolt kit for this purpose.

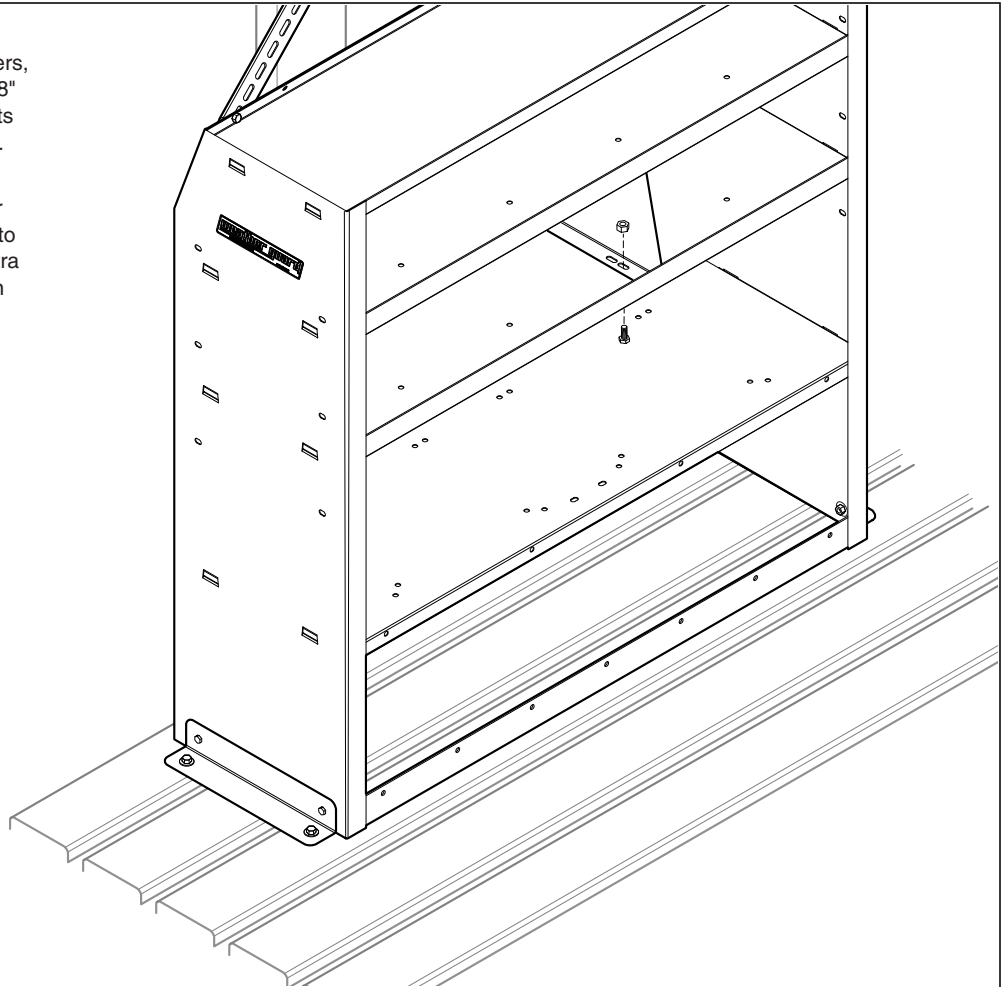

## WARNING

Prior to drilling, so as not to cut or puncture fuel tanks, fuel lines, brake lines, electric wires, etc., check behind or underneath drilling and mounting locations.



## CAUTION

To keep debris out of your eyes when checking the underside of the vehicle, or when drilling, always wear protective eyewear.

Place a drop of oil on the black oxide bolt before assembling as shown on right. Place the Blind Fastener in the hole and use a 7/16" wrench to tighten black hex bolt until the Blind Fastener is fully seated. When setting black hex bolt, it will start out hard. As the Blind Fastener "bulbs" out it will get easier, until it bottoms out or sets. Make sure the Blind Fastener and Installation Tool do not turn during installation.

## INSTALLATION INSTRUCTIONS FOR BLIND FASTENERS

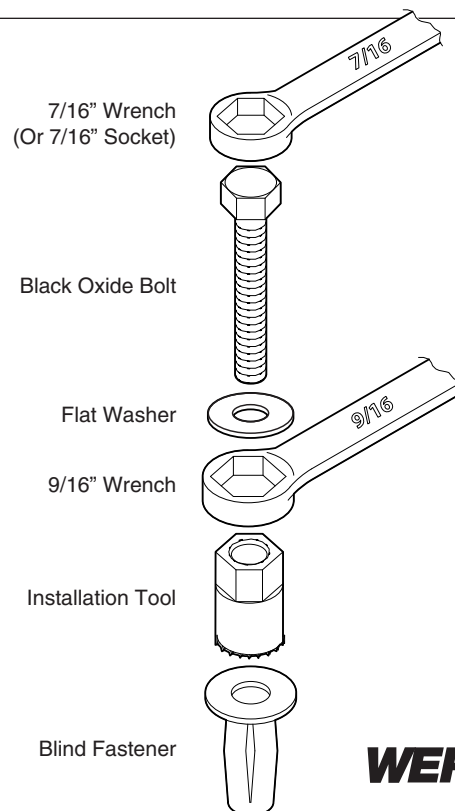

**WERNERCO™**