



VAN STORAGE SOLUTIONS
FOR THE WAY YOU WORK™

INSTALLATION MANUAL

SLIDING LADDER RACK Model 250

ATTENTION: PLEASE READ AND UNDERSTAND ALL INSTRUCTIONS AND WARNINGS BEFORE ASSEMBLING, INSTALLING OR USING THIS PRODUCT.

NOTE: This product is only intended for use inside a van, enclosed trailer or truck with metal cap.

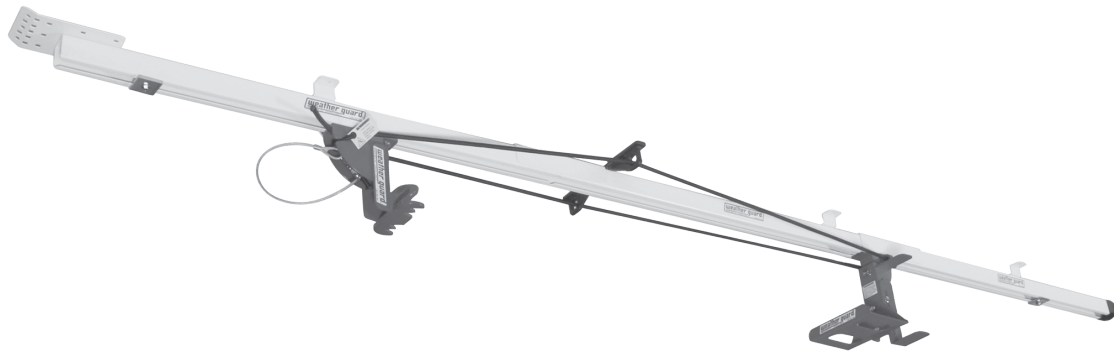

WARNING

To reduce the risk of serious personal injury from the ladder falling or becoming a projectile during hard braking or a vehicle accident:

- Read and follow all instructions and warnings before installing or using this product.
- The sliding ladder rack should only be used for transporting ladders. Never modify or use the sliding ladder rack for any other purpose.
- Rack must be installed per instructions.
- Only mount the sliding ladder rack in a van, enclosed trailer, or metal truck cap.
- Maximum ladder weight should not exceed 80 lbs.
- When using power tools, follow tool manufacturer's warnings and instructions.
- Protect your eyes. Wear safety goggles that comply with ANSI Z87.1 (or in Canada, CSA Z94-3-M88) as shown on package.
- Never install the sliding ladder rack system inside passenger compartments.
- Check for electrical wiring in areas where holes are to be drilled. Consult the vehicle's shop manual for wiring paths.

CAUTION

Weather Guard recommends the Model 250 sliding ladder rack be installed in service or delivery vans equipped with a bulkhead. A bulkhead divider between cargo and driver/passenger compartment reduces the likelihood material will come forward and cause personal injury during a vehicle accident.











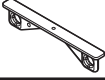







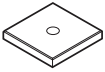





INSTALLATION TIME

Approximate installation time: 60 minutes per unit (1 hour) depending on van equipment installation experience. **Rail assembly installation requires 2 people.**

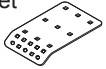
TOOLS REQUIRED

- Electric Drill
- 5/16" Hex Driver Bit
- Phillips Screw Driver
- Ruler
- 7/16" Wrench
- 7/16" Deep Well Socket
- Ratchet Wrench
- Lithium Grease

PARTS LIST

(1) Cord guide 	(24) 1/4" Flat Washer 	(1) Front cradle 	(2) Connecting bracket 
(4) Strut channel nut 	(1) Pan head machine screw, 1/4 x 20 x 7/8 	(1) Inside side catch 	(3) Mounting bracket 
(2) Stop plate 	(2) Shock cord 	(1) Outside side catch 	(1) Vinyl cap 
(1) 1.25 OD Washer 	(4) Lock washer 	(1) Fixed catch 	(8) 1/4 - 14 x 3/4 self-drilling screw 
(4) Hex head cap screw, 1/4 x 20 x 1 	(1) Adjustable mount 	(17) Carriage bolt, 1/4 x 20 x 3/4 	(1) Rear mounting bracket 
(20) Nylon lock nut, 1/4 x 20 	(1) Fixed mount 	(1) Safety cable assy. 	
(2) Carriage bolt, 1/4 x 20 x 1-1/2 	(1) Adjustable arm 	(3) Rail 	

INSTALLATION INSTRUCTIONS

Step 1: RAIL ASSEMBLY INSTALLATION

Using connecting brackets (2), connect rail sections (3) using eight 1/4-20 x 3/4" carriage bolts, 1/4" flat washers and 1/4-20 nylon lock nuts.

NOTE: The installation instructions below are written for the installation of this product to the roof ribs of a van or truck cap. This rack can be mounted to the side wall of a trailer if desired, using the same steps described below.

NOTE: Depending on the size and type of your vehicle, the rail assembly may need to be cut to length for proper installation, Measure the distance inside the van, and cut the assembled rail to the correct length.

Determine the rail mounting location inside vehicle (center, off-center, side). Measure the first three van rib locations from the rear of the van, starting from the upper inside of the rear door jamb, and measuring forward. Record those dimensions.



CAUTION

Rail assembly must be attached to all three roof ribs for proper installation.

Fasten the rear mounting bracket to the rear of the rail assembly (end opposite cut end) using two 1/4-20 x 3/4" carriage bolts, 1/4" flat washers and 1/4-20 nylon lock nuts. See Figure 1a. From the rear of the rear mounting bracket, mark the rail assembly at the recorded rib locations. Fasten a mounting bracket just tight enough to be adjusted by hand, centered at each mark, using one 1/4-20 x 3/4" carriage bolt, 1/4" flat washer and 1/4-20 nylon lock nut each.

Place the rail assembly in the vehicle in position. Determine whether the rear mounting bracket needs to be modified. It may be offset to the rail assembly or have a portion of it removed or the angle of the flange changed to meet the door jamb flush, if necessary. Adjust the mounting bracket locations on the rail assembly if necessary, to insure that the mounting brackets can be properly fastened to the roof ribs.

Remove the rail assembly from the roof ribs, and tighten the mounting brackets securely.

Place the rail assembly back in position, and fasten it to the roof ribs and rear door jamb with two 1/4-14 x 3/4" self drilling screws and 1/4" flat washers per bracket.

Fasten the cord guide approximately 30" in from the rear of the rail assembly, using a 1/4-20 x 7/8" pan head machine screw, 1-1/4" OD washer, 1/4" flat washer and 1/4-20 nylon lock nut. Adjust the 30" dimension for obstructions if necessary.

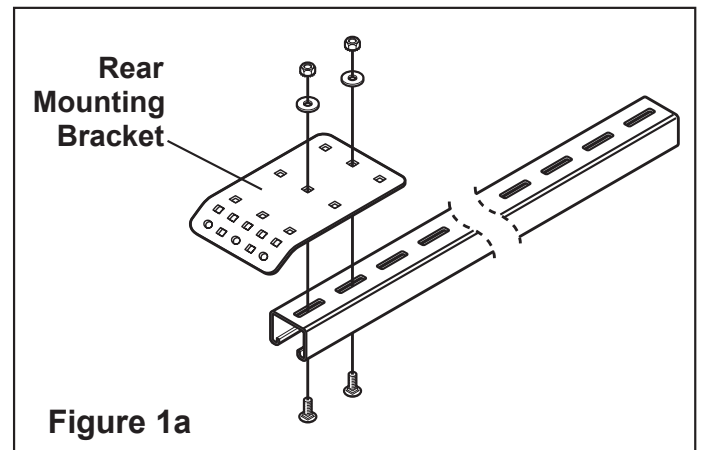
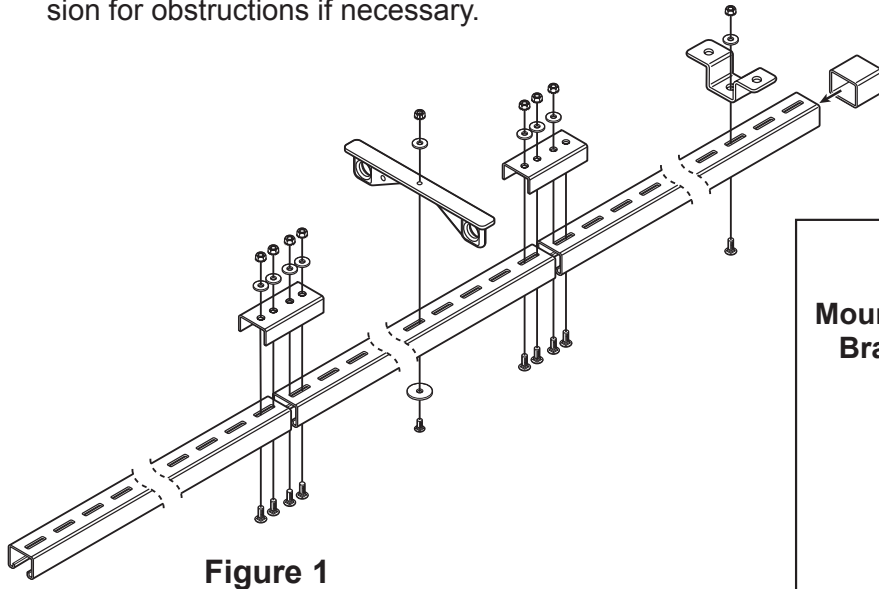

Step 2: INSTALLING FIXED MOUNT

Measure from the foot of the ladder to the bottom rung. From the back of the rail assembly measure the same distance and mark the rail. This will be the approximate location of the fixed mount. Install the fixed mount with grooves facing the front of the vehicle. Allow for position adjustment using fasteners shown in Figure 2.

Figure 2

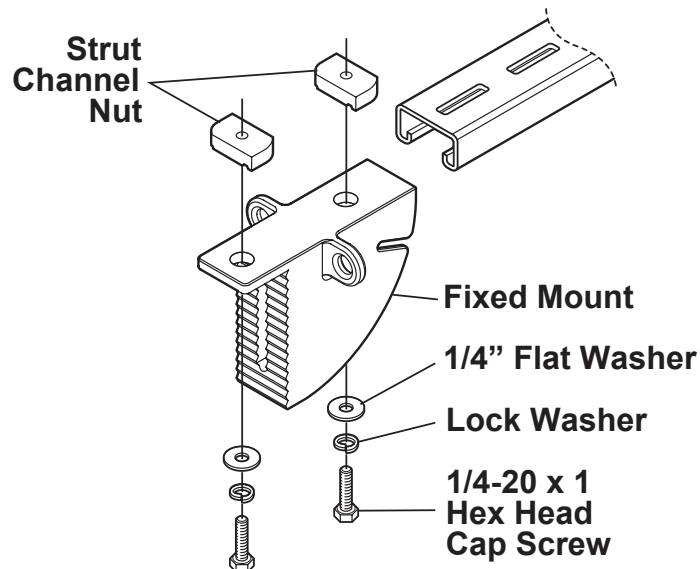

Step 3: INSTALLING SLIDING MOUNT

Insert the sliding mount into the rail assembly with the grooved portion facing the rear of the vehicle. Install the vinyl cap over the cut end of the rail assembly.

Step 4: FRONT CRADLE ASSEMBLY INSTALLATION

NOTE: If installing this sliding ladder rack to the side wall of a trailer, proceed to Step 10 for the side catch assembly.

Using two 1/4-20 x 7/8" carriage bolts, 1/4" flat washers, and 1/4- 20 nylon lock nuts, affix front cradle to extension arm. Attach to sliding mount. With one 1/4-20 x 1-1/2" carriage bolt, 1/4" flat washer, and 1/4-20 nylon lock nut, adjust the depth of the cradle to fit the height of your ladder. Tighten carriage bolt completely (Figure 3).

! CAUTION

Do not over tighten fasteners.

Figure 3

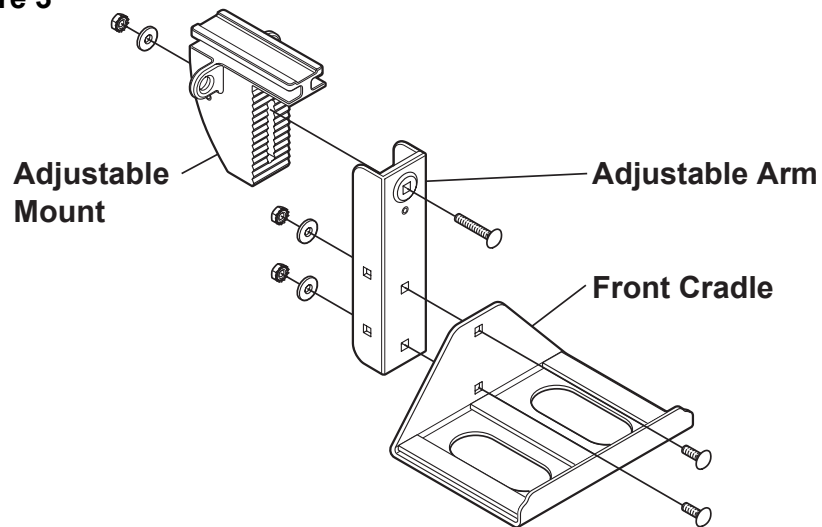

Step 5: FIXED CATCH

Using one 1/4-20 x 1-1/2" carriage bolt, 1/4" flat washer, and 1/4- 20 nylon lock nut, affix the fixed catch and safety cable to the fixed mount allowing for adjusting the depth to fit the bottom rung of the ladder. Tighten carriage bolt completely (Figure 4).

! WARNING

- Safety cable must be attached per instructions for ladder to be properly secured to rack and vehicle.
- Do not over tighten fasteners.

Figure 4

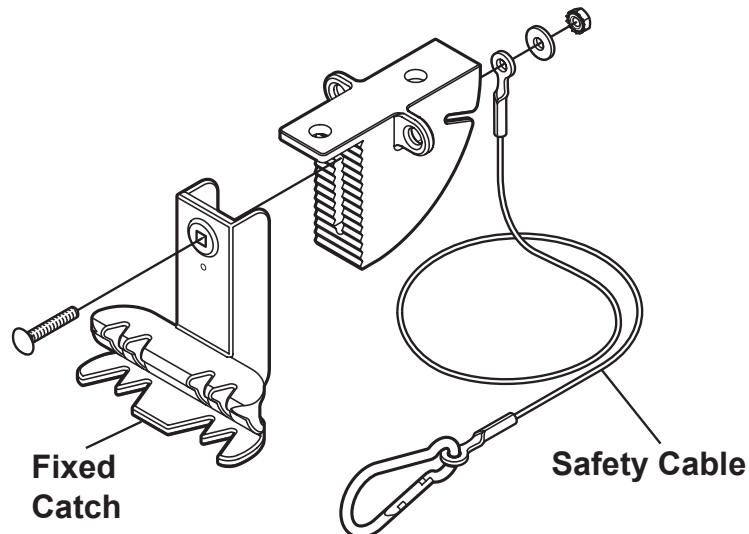

Step 6: ADJUSTING MOUNTING POSITIONS

Place ladder onto the front cradle and slide forward to the stowed position. Place the bottom rung of the ladder onto the fixed catch. This will be the final position of the fixed catch assembly. Gently remove the ladder so as not to move the fixed catch and finish securing the fixed catch assembly in place.

! CAUTION

- Fixed Catch assembly is not completely secured at this point. When placing ladder into position it could fall.
- Do not allow anyone directly underneath or to the side of ladder during this installation step, except to help with mounting.

Step 7: SHOCK CORD INSTALLATION

Slide the shock cords through the adjustable mount shock cord holes. Make sure the hog ring is at the back of the unit. Next slide the cords through the shock cord guide holes, and then through the fixed mount shock cord holes.

! CAUTION

- Elastic cords can snap back and strike your eye. Do not over stretch. Keep your body and face clear.
- Elastic cords must be properly adjusted. Failure to adjust cord tension for length of ladder may allow ladder to fall.

Place ladder onto rack and slide forward while holding the shock cord. When the ladder is in the stowed position, firmly pull the shock cord and slide it into the holding slot on the back of the fixed mount (see figure 5).

Make sure to have enough tension on the shock cord to securely hold the ladder in place. Tie a double knot into the end of the shock cord at this point, and insert the cords in the slots in the fixed mount. Tuck the excess into the back of the fixed mount (see figure 5).

Figure 5

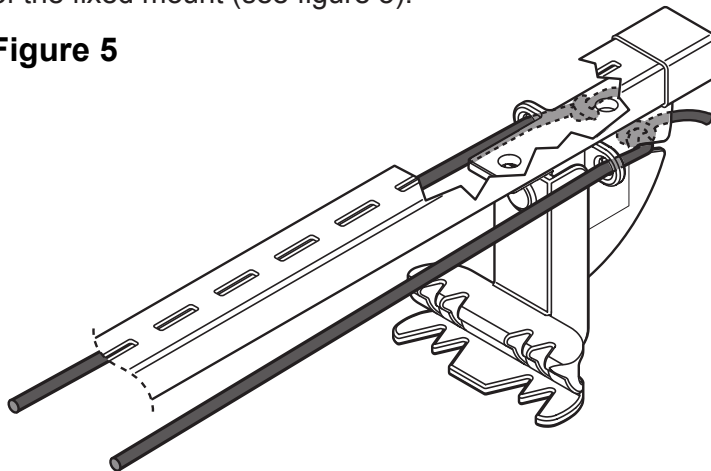

Step 8: INSTALL FORWARD AND REAR STOPS

Recommended position of the forward stop is approximately 1" in front of the sliding mount in the stowed position. The position of the stop should allow just enough travel to slide the ladder forward to place the bottom rung onto the adjustable catch as well as ladder removal.

Rear stop should be placed far enough forward to limit travel of the sliding mount allowing you to pull the ladder easily off of the front cradle assembly without hitting the fixed catch.

! WARNING

Front Stop Plate must be installed to prevent the sliding catch from dislodging during hard braking or in a vehicle accident.

Step 9: RAIL LUBRICATION

Apply a generous amount of lithium grease to the inside of the rail allowing for smooth travel of the sliding front cradle.

Optional Installation

Step 10: SIDE MOUNTING INSTALLATION INSTRUCTIONS (ONLY)

Install side catch brackets to adjustable mount with two 1/4-20 x 7/8" carriage bolts, 1/4" flat washers, and 1/4-20 nylon lock nuts as shown in Figure 6. Install rail assembly to side of enclosed trailer.

Figure 6

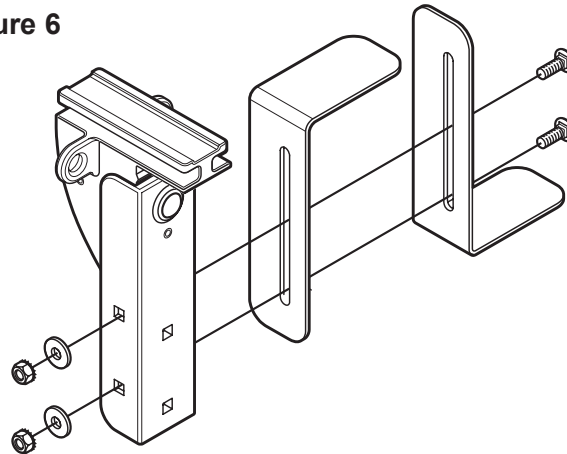

USAGE INSTRUCTIONS

Before loading ladder into rack:

1. WEATHER GUARD recommends the Model 250 sliding ladder rack be installed in service or delivery vans equipped with a bulk head. A bulkhead divider between cargo and driver/passenger compartment reduces the likelihood material will come forward and cause personal injury during a vehicle accident.
2. The sliding ladder rack is designed to be loaded from the back of a cargo van or pickup truck with a metal cap.
3. Before loading a ladder, make sure the elastic cords and the stop bracket are installed and positioned correctly. See Installation steps 7 & 8 on pages 3 & 4. If a different size ladder is to be loaded then the stop bracket and the elastic cords must be adjusted or the ladder will fall from the rack.
4. Inspect the parts of the ladder rack before using. If any part is broken, bent or damaged in any way do not use rack. See Maintenance section for replacement parts.

! WARNING

- Inspect the sliding ladder rack before each use. Do not use rack if it is damaged or deteriorated in any way.
- Do not place shorter ladder in rack adjusted for longer ladder. Always adjust stop plate and elastic cords for length of ladder being loaded.
- Incorrect loading or unloading of the sliding ladder rack could allow ladder to fall and cause serious personal injury or property damage.
- Never operate the rack with persons seated below or near the rack and ladder.
- Be careful when loading ladder into the sliding ladder rack if standing on slick or icy ground.
- Do not load or unload ladder when vehicle is moving.

Loading ladder into rack:

1. Ensure the ladder is clean and dry.
2. Open van's rear doors or truck hatch to access rack.
3. Pull on elastic cords to move the sliding catch toward the rear.
4. Position the ladder with the step side down (non-step side up).
5. Lift the top of the ladder and place it in the front cradle. See Figure 7.

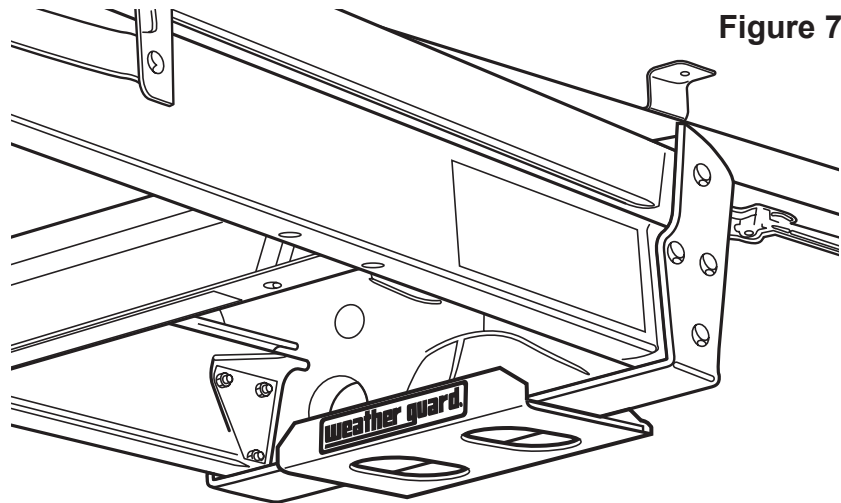

Figure 7

6. Moving to the foot of the ladder, lift and push forward, causing the sliding mount to move forward and the elastic cords to become tight. Stop if elastic cords become tangled with the ladder. Straighten cords and continue.

7. With a firm two hand grip on the ladder, push and lift so that the underside of the bottom step is aligned with the face of the fixed catch. Ease your forward pressure and allow the elastic cords to push the step against the fixed catch.

Note: The face of the fixed catch is designed to engage a variety of step designs. If the bottom step on your ladder does not engage securely with the fixed catch try to reposition the step. If you need to adjust the fixed catch's mounting position, refer to the installation instructions in Step 4 on page 3.

8. Ensure the ladder is properly engaged with the fixed catch.

9. Loop the safety cable around the bottom step and clip it back on itself as shown in Figure 8. Always attach the safety cable around a step. Other parts of the ladder may not be strong enough to hold the ladder in a vehicle accident.

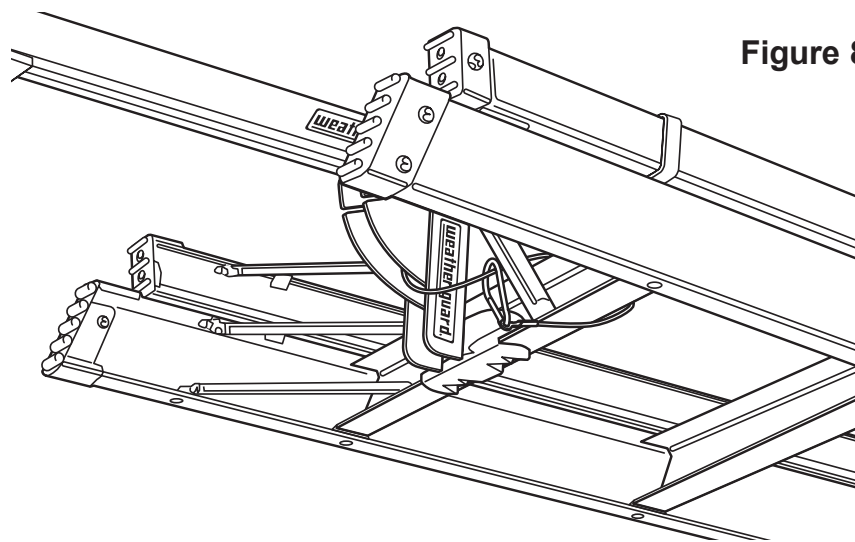

Figure 8

! WARNING

- Always attach safety cable around ladder step. Safety cable reduces the risk of the ladder coming free during a vehicle accident.
- Inspect ladder before each use. Ladder can be damaged from road shock and vehicle vibration. Bouncing and side-to-side motion may cause wear and weaken the ladder. Using a damaged ladder could lead to structural collapse and result in serious injury or death.
- Keep hands clear of area where ladder engages rack.

Unloading ladder from rack:

1. To un-load ladder from rack, reverse the loading process above while following these steps.
2. Make sure you have secure footing and a clear path behind your vehicle to walk the ladder out.
3. Check that the ladder has not shifted in the rack and is still securely held by the fixed catch.
4. Remove the safety cable from around the step.
5. Push the ladder forward and then down to disengage the step from the face of the fixed catch. Be prepared for the push-back from the elastic cords.
6. Walk away from the vehicle until the top of the ladder has slid to near the fixed catch.
7. For long or heavy ladders, set the bottom of the ladder down to the ground and then move up the side of the ladder to a position and lift the top from the front cradle.

GENERAL MAINTENANCE

Conduct periodic inspection of your sliding ladder rack for wear and tear, damage or loose parts. Repair or replace as necessary.

Apply a generous amount of lithium grease to the inside of the rail allowing for smooth travel of the sliding front cradle.

Check the elastic cords for damage and wear. If cloth covering is frayed, cord could break unexpectedly. Replace the cords before using the rack.

Check the safety cable for damage or breakage. Look for broken strands. If found replace cable before using the rack.

! WARNING

- To reduce the risk of personal injury:
- Do Not use ladder rack with missing or damaged parts.
- Inspect elastic cords for wear. If cloth covering is frayed, cord could break unexpectedly. Do not use rack.
- Maintain grease on rail.

SERVICE PARTS

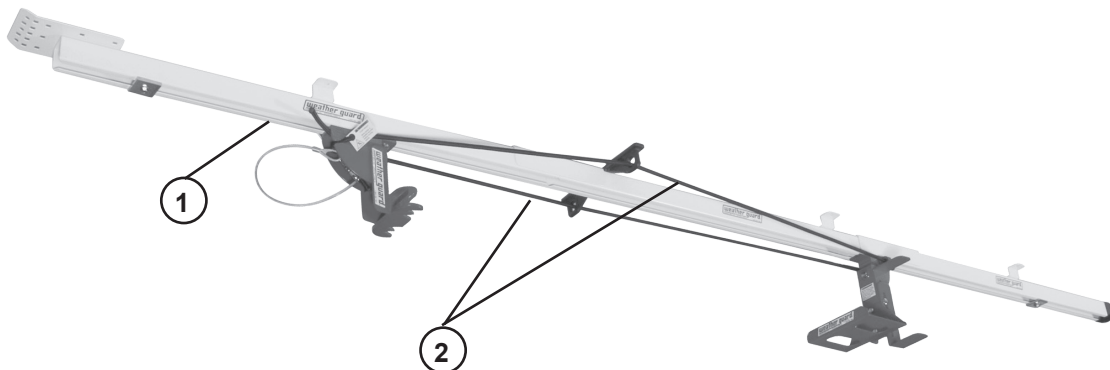

ITEM NO.	PART NO.	DESCRIPTION
1	7947	Safety Cable
2	7948	Shock Cord (1 pair)
3	7949	Bolt Kit (not shown)