

ASSEMBLY AND INSTALLATION INSTRUCTIONS

CONDUIT CARRIER - Model 239

IMPORTANT BEFORE YOU BEGIN

Read these instructions and warnings completely before installation.

BOLT KIT

Bolt kit #32-2390 is provided with your Conduit Carrier. Check this bolt kit to be sure the following parts are included:

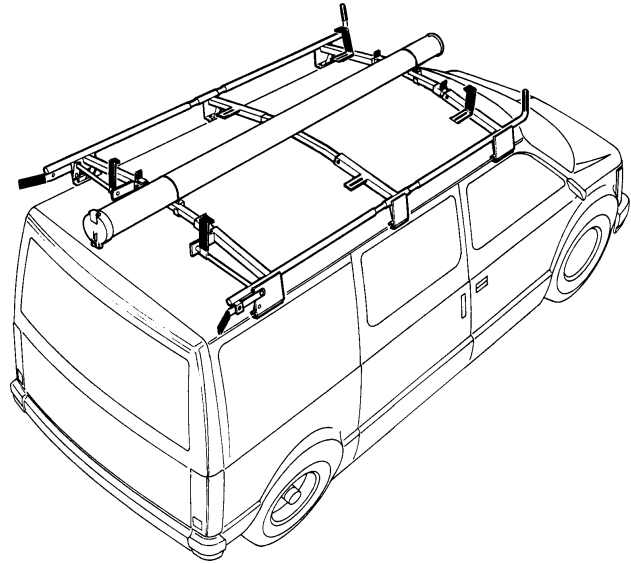

Quan.	Description
-------	-------------

4	#12-24 Nylon Lock Nuts (black dichromate)
---	--

PARTS LIST

- 2 - "U" Clamps
- 1 - Front End Cap
- 1 - Rear End Cap with Door
- 4 - Clamp Brackets

TOOLS & MATERIALS NEEDED

- 3/8" Open or Box End Wrench
- Plastic Pipe Cement
- PVC Primer
- PVC Pipe

NOTE: Use only the recommended ASTM material, which is PVC 1120 Schedule #40. The 6" diameter pipe should fit snugly on the end cap. If it does not, this is an indication that you have the wrong size pipe. Be sure to follow application instructions found on the cement container.

⚠ WARNING

This product is only intended for, and only safe for, storing and transporting tubing, pipe and conduit. Any modifications made to this product, or use of this product for any other purpose than its intended use, could create a hazardous condition that can cause serious personal injury or property damage.

ASSEMBLY AND INSTALLATION INSTRUCTIONS

1. Be sure the 6 in. PVC Pipe is cut squarely on both ends and to correct length (10 ft.). Any rough edges should be smoothed with a file.
2. Before cementing the end caps in place, be sure to clean away any dirt, grease or moisture from both ends of the PVC pipe.
3. Use a plastic primer to remove surface gloss from pipe ends and inside flanges of end caps.

NOTE: Keep the door End Cap open during priming, gluing and curing steps to prevent possibility of sealing the door shut.

4. Assemble Rear End Cap to PVC pipe. Apply a thin coat of Plastic Cement to the inside flange of the end cap...then quickly apply a liberal cement coat around the outside of the PVC pipe.

5. While the cement is still wet, push the End Cap onto the PVC pipe with a slight turning motion until it is fully seated on the pipe.

NOTE: Keep pressure on the end cap for approximately 30 seconds for a good seal.

6. To assemble the Front Cap to the PVC pipe, repeat steps 4 and 5, making sure the Triangular Tab lines up with the center of the hinge pin on the rear end cap (see Figure 1.).

weather guard

DIVISION OF KNAACK MFG. CO.

⚠ WARNING

Rear end cap door must be padlocked during transit to prevent accidental spillage of contents, which could cause serious personal injury or property damage.

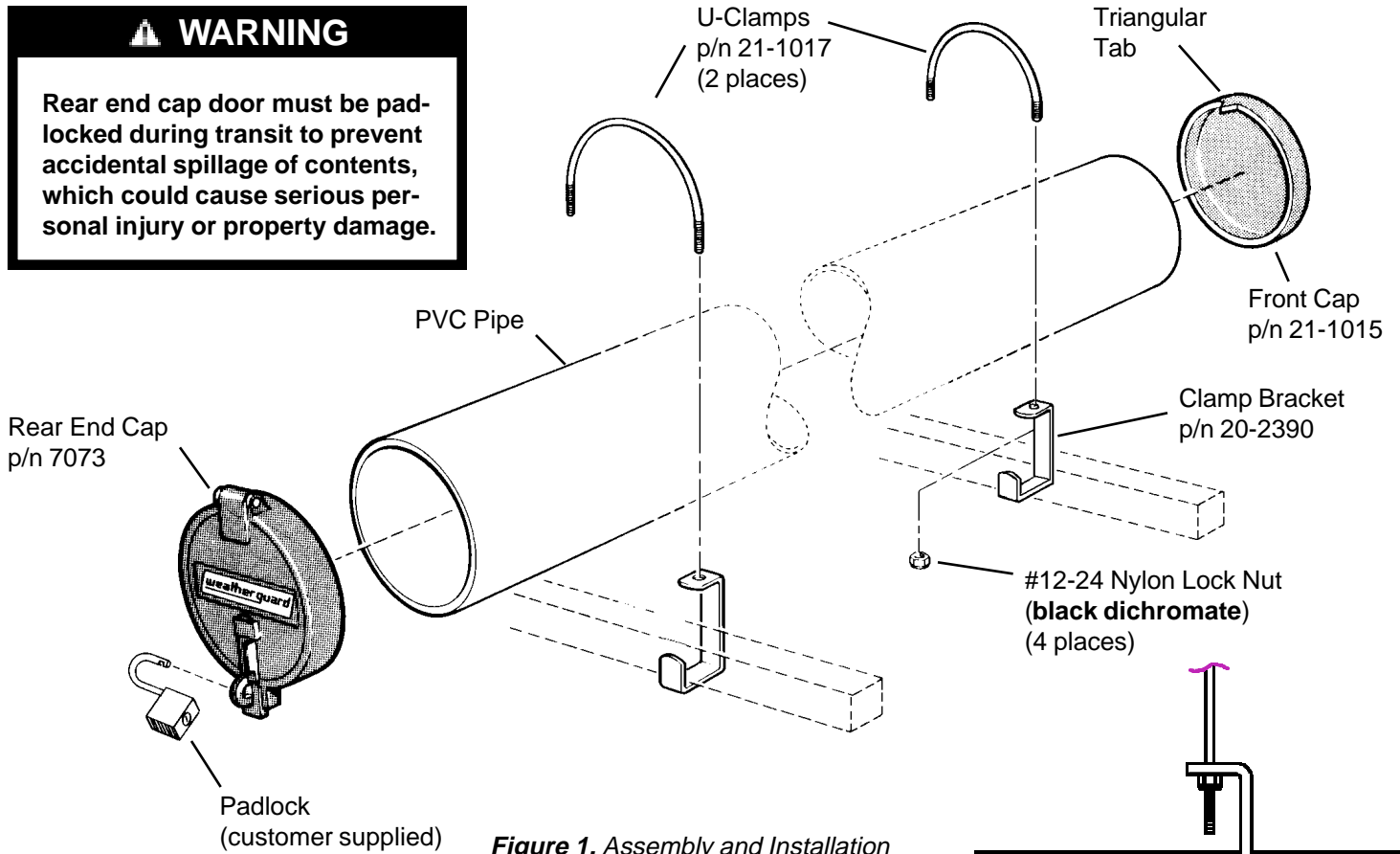

Figure 1. Assembly and Installation on a square shaped crossmember

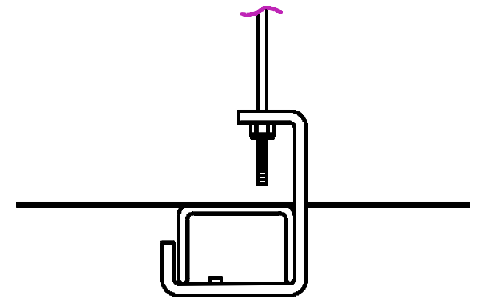

Figure 2b. Installation on a channel shaped crossmember

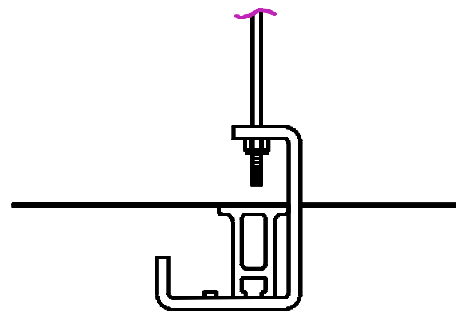

Figure 2a. Installation on a 211 aluminum crossmember

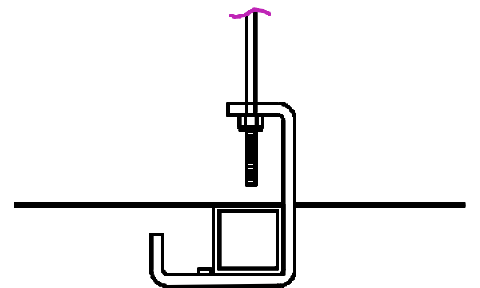

Figure 2c. Installation on a square shaped crossmember

⚠ WARNING

Allow at least 15 minutes for cement cure time before handling, and we strongly suggest a 24 hour full-cure time before loading any materials. If assembled Conduit Carrier is used before the 24 hour cure time, the material in the conduit carrier could push the end caps out and spillage of material could occur causing serious injury to persons and property.

7. Place the Conduit Carrier in position on your ladder rack. Install the "U" Clamps and Clamp Brackets (see Figure 1.). (See Figures 2a, 2b and 2c for installation of "U" Clamps and Clamp Brackets for your crossmember). Before tightening the nuts, make sure the conduit carrier is correctly positioned and the rear door latch is pointing down as shown in the illustration.

- NOTICE -

Any modification or unintended use of this product shall immediately void all manufacturers warranties. Manufacturer disclaims all liability for injuries to persons or property resulting from any modification to, or unintended use of this product.