



VAN SOLUTIONS
FOR THE WAY YOU WORK™

EZGlide2™

INSTALLATION MANUAL



Models 2275-3-01 & 2277-3-01



ATTENTION: PLEASE READ AND UNDERSTAND ALL INSTRUCTIONS AND WARNINGS BEFORE ASSEMBLING, INSTALLING OR USING THIS PRODUCT.

 **CAUTION**

Be safe - always wear protective eye wear to keep debris out of your eyes when installing WEATHER GUARD® Van Products

 **WARNING**

Prior to drilling, check under vehicle for fuel, tanks, fuel lines, brake lines, electric wires, etc. To avoid cutting or puncturing them. Do not use Blind Fasteners in these areas.

Tools Needed

- THREADLOCKER COMPOUND
- 1/2" SOCKET AND/OR WRENCH
- 3/16" HEX KEY/DRIVER
- 1/4" HEX KEY/DRIVER
- (2) 9/16 SOCKET AND/OR WRENCH
- TORQUE SETTABLE DRIVER OR TORQUE WRENCH.
- NEEDLE NOSE PLIERS
- LADDER OR WORK PLATFORM

BEFORE YOU BEGIN

The best time to install the EZGLIDE2™ dual drop-down ladder rack when first installing the rack on the vehicle. After checking that your product is complete, follow along with the single drop-down installation instructions, adding the dual drop-down parts at the same time.

These instructions are written assuming that you are adding a dual-drop down kit to an existing installation.

CONTENTS

EZGLIDE2 PARTS LIST	4
STEP 1 INSTALL VERTICAL TUBE AND DAMPER	6
STEP 2 INSTALL LADDER HOOKS	7
STEP 3 MOUNT MOUNTING FEET TO CROSS MEMBERS	8
STEP 4 INSTALL CURVED MOUNTING BRACKETS	9
STEP 5 INSTALL DROP DOWN MECHANISMS TO CROSS MEMBERS.....	12
STEP 6 MOUNT CENTER CROSS MEMBERS TO VEHICLE.....	13
STEP 7 INSTALL CENTER CONNECTING TUBE	15
STEP 8 INSTALL REAR DRIVE TUBE	16
STEP 9 INSTALL REAR COUPLING.....	16
STEP 10 POSITION AND SECURE LADDER RACK ASSEMBLY	17
STEP 11 ADJUST LADDER HOOKS.....	18
EZGLIDE2 SPARE PARTS LIST.....	19

EZ GLIDE2 PARTS LIST

DESCRIPTION	2275-3-01 QTY	2277-3-01 QTY
FIXED DROP DOWN	2	2
36" CONNECTING TUBE		1
70" CONNECTING TUBE	1	
89" CONNECTING TUBE	1	
REAR DRIVE TUBE	1	1
REAR COUPLING	1	1
MOUNTING FOOT		2
VERTICAL LADDER STOP	2	2
DAMPER	2	2
70" CROSS-MEMBER		1
FIXED LADDER HOOK	2	2

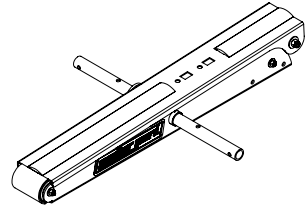

FIXED DROP DOWN

70" CONNECTING TUBE

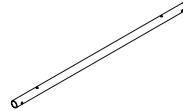

36" CONNECTING TUBE

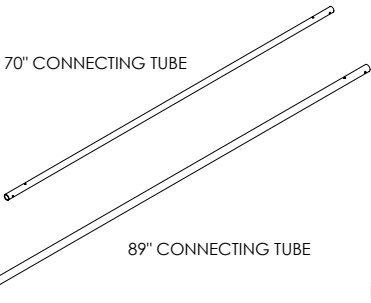

89" CONNECTING TUBE



REAR DRIVE TUBE



REAR COUPLING



MOUNTING FOOT

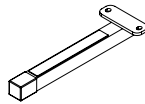

VERTICAL LADDER STOP

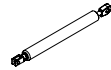

DAMPER

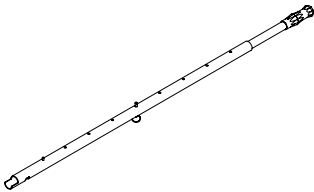

TELESCOPING HANDLE

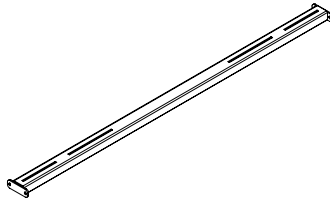

70" CROSSMEMBER

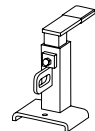

FIXED LADDER HOOK

DESCRIPTION	2275-3-01 QTY	2277-3-01 QTY
5/16" WASHER	18	44
5/16 x 1-3/4" BOLT	6	6
5/16 x 2" SCREW	4	4
RED CAP	1	1
1" SPACER	4	4
5/16 NYLON LOCK NUT	12	36
3/8 WASHER	4	4
3/8 x 7/8" BOLT	2	2
3/8 NYLON LOCK NUT	2	2
MOUNTING PLATE		2
COUPLING BUSHING	1	1
CLEVIS PIN	1	1
5/16 x 7/8" CARRIAGE BOLT	4	18
E-CLIP	2	2
DAMPER ROD	2	2
5/16 x 1-1/4" CARRIAGE BOLT		4
5/16 x 1-1/4" BOLT		2
CURVED MOUNTING BRACKET		2
MOUNTING FOOT BOLT PLATE		2
UNIVERSAL CLAMP		2
5/16 x 1-3/4" CARRIAGE BOLT		2

NOTE: SOME ADDITIONAL PARTS MAY BE INCLUDED FOR USE WITH OTHER LADDER RACKS.

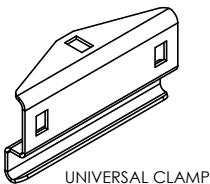
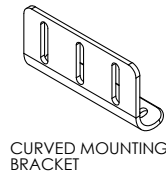
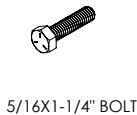
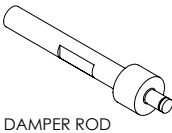
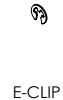
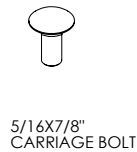
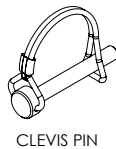
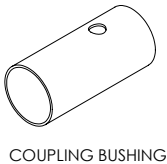
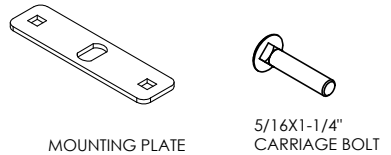
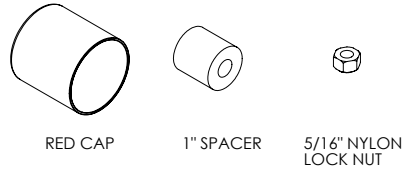
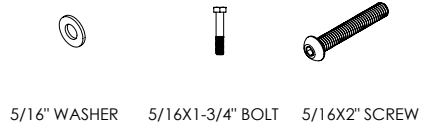

STEP 1 - INSTALL VERTICAL TUBE AND DAMPER

Using the damper, damper rod and (1) e-clip, install the eyelet end of the damper to the damper rod using (1) e-clip. The damper comes with a preinstalled clip on the clevis end side. Remove clip, slide clevis end over the drive tube cam, and reinstall clip. The needle nose pliers will help with this operation.

Using (2) 5/16x2" screws, (2) 1" spacers, (1) 5/16" nylon lock nut, (1) 5/16" washer, and (1) damper rod, install the vertical ladder stop to each drop down unit. The inner mounting point will use the 5/16" washer and nut, While the outer mounting point will use the damper rod for the 5/16x2" screw. It is recommended to use thread locking compound on the 5/16x2" screw that threads into the damper rod. Torque both the 5/16" nut and damper rod to 10 ft-lbs.

Repeat with the other drop down unit.

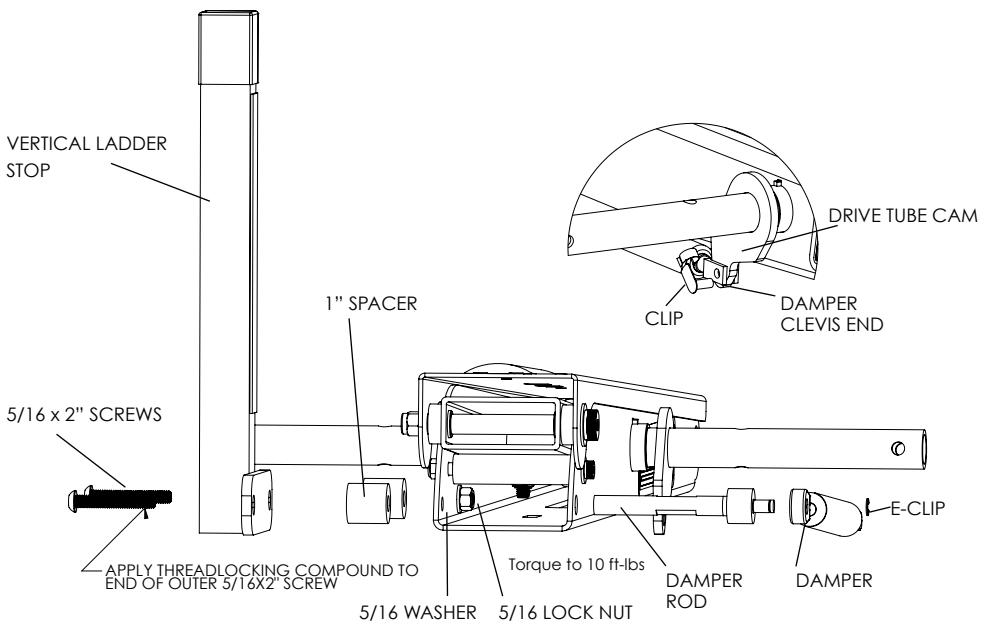

STEP 2 - INSTALL LADDER HOOKS

Using (1) 3/8x7/8" bolt, (1) 3/8" nylon lock nut, and (2) 3/8" washers install the fixed ladder hook to the drop down unit. The hook should be located according to the diagram in the upper set of holes, but may be adjusted depending on ladder dimensions and user preference. Torque nut to 26 ft-lbs.

Repeat for second drop down unit.

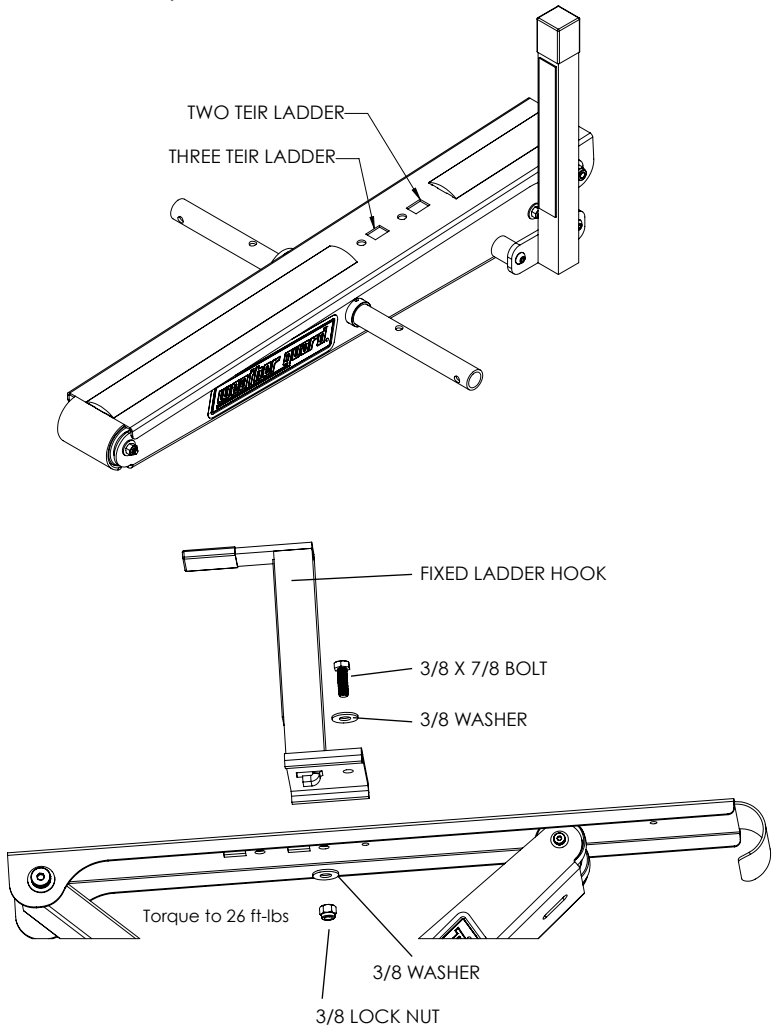



• FOR 2275-3-01, PROCEED TO STEP 5

STEP 3 - MOUNT MOUNTING FEET TO CROSS MEMBER

Only use one carriage bolt, washer, and nut per mounting foot.

Using (1) 5/16x7/8" carriage bolt, (1) 5/16" washer, and (1) 5/16" nylon lock nut per mounting foot, install two mounting feet per cross member. Please refer to the table and diagram for mounting foot location and orientation.

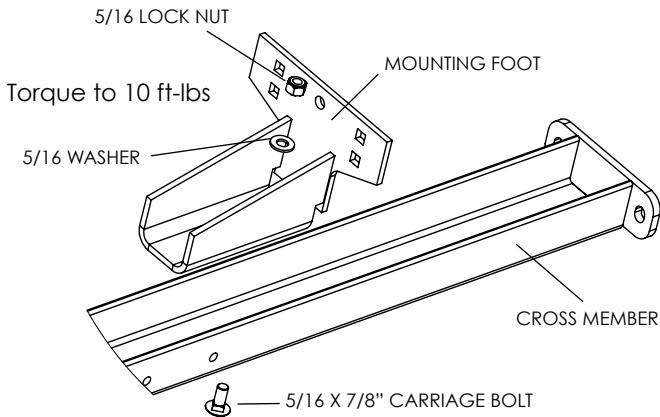

INSTALL MOUNTING FEET ACCORDING TO TABLE

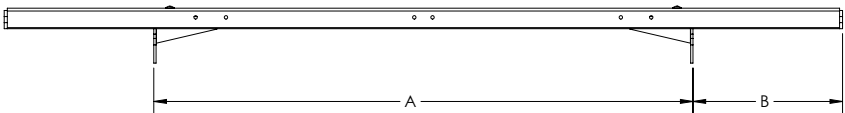

MOUNTING FOOT DISTANCE		
VEHICLE	DIM "A"	DIM "B"
FORD TRANSIT CONNECT (FRONT)	46-1/4"	6-3/8"
FORD TRANSIT CONNECT (REAR)	47-1/4"	5-7/8"
RAM PROMASTER CITY (FRONT)	42"	8-1/2"
RAM PROMASTER CITY (REAR)	41-3/8"	8-13/16"
CHEVY CITY EXPRESS	45-3/8"	6-13/16"
NISSAN NV200	45-3/8"	6-13/16"

STEP 4 - INSTALL CURVED MOUNTING BRACKETS

Most vans will use a mounting channel kit for installing the EZGLIDE2™ van rack. Follow STEP 4A for these applications. For gutter mounting, follow STEP 4B.

STEP 4A - FOR CHANNEL MOUNTING APPLICATIONS

Using (2) 5/16X7/8" carriage bolt, (2) 5/16" washer, and (2) 5/16" nylon lock nut per mounting foot install a curved mounting bracket to each mounting foot. Torque nuts to 10 ft-lbs.

If using an impact driver to torque nuts, it is recommended that the carriage bolt orientation be reversed to engage the square cut outs in the mounting foot.

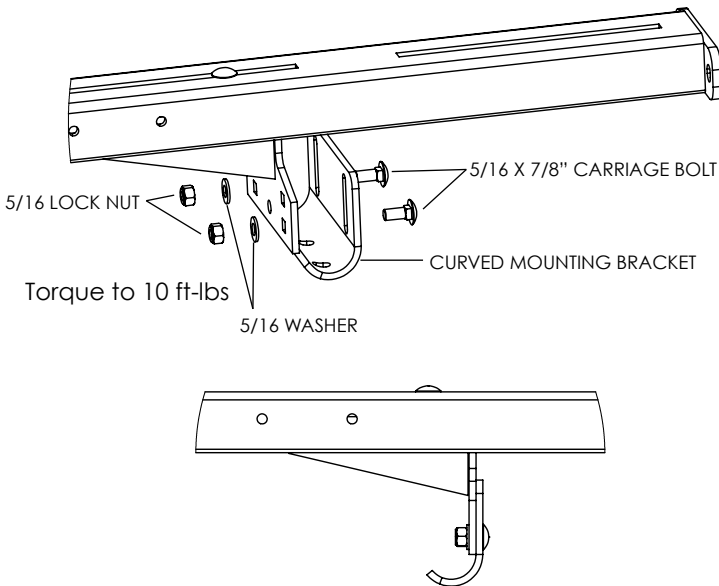

Most vehicle installations will benefit from having the lowest installed height with the mounting bracket lining up with the start of the curve on the curved mounting bracket. Due to vehicle roof curvatures some adjustment for final assembly height may be required after the crossmembers are installed on the roof.

STEP 4B - GUTTER MOUNT APPLICATIONS

FOR GMC SAVANA AND CHEVROLET EXPRESS VANS

Assemble the curved mounting bracket and the universal mounting clamp to the mounting base with (2) 5/16-18x1-1/4" carriage bolts, (2) 5/16 washers and (2) 5/16 lock nuts. Do not tighten. Insert (1) 5/16-18x1-3/4" carriage bolt into the curved section of the mounting bracket and through the square hole in the universal mounting clamp. Hold it in place with (1) 5/16 washer and (1) 5/16 lock nut. Do not tighten.

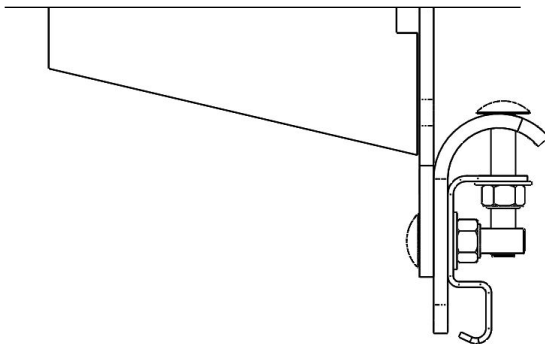
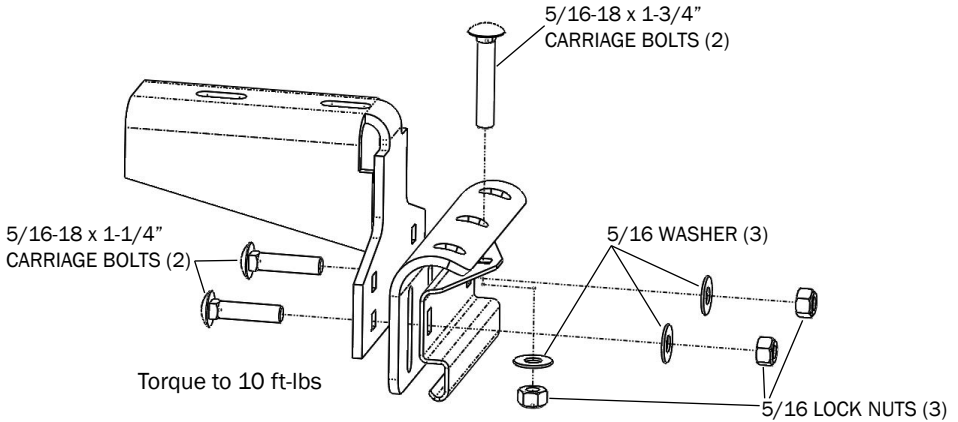

STEP 4B - GUTTER MOUNT APPLICATIONS (cont.)

FOR FORD ECONOLINE VANS

Assemble the curved mounting bracket to the cross member mounting base with (2) 5/16-18x7/8" carriage bolts, (2) 5/16 washers and (2) 5/16 lock nuts as shown in the figure below. Loosly tighten to allow some adjustment at this time.

Assemble the universal mounting clamp to the curved mounting bracket with (2) 5/16-18x1-1/4" carriage bolts, (2) 5/16 washers and (2) 5/16 lock nuts. Do not tighten. Next, insert (1) 5/16-18x1-3/4" carriage bolt into the top of the curved mounting bracket and through the square hole in the universal mounting clamp. Hold it in place with (1) 5/16 washer and (1) 5/16 lock nut. Do not tighten.

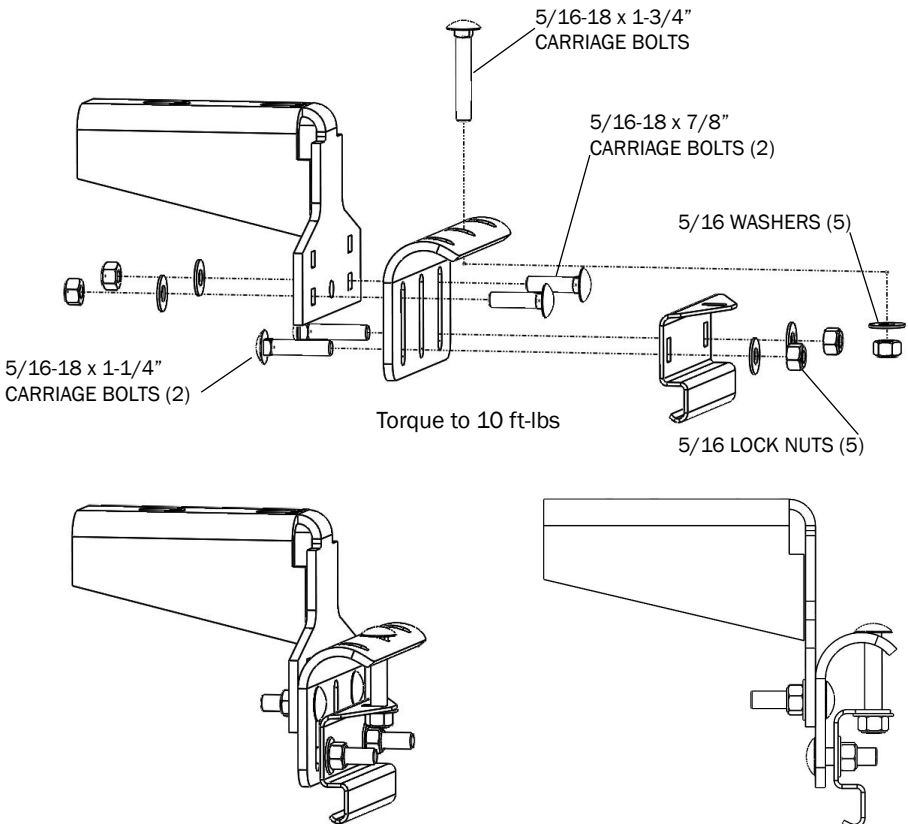

STEP 5 - INSTALL DROP DOWN MECHANISMS TO CROSS MEMBERS

If adding the 2265-3-01 or 2267-3-01 to an existing rack, installation will be easier if you can get more access between the rear cross member and van roof. Begin by loosening the 5/16 Lock Nuts holding the cross member to the mounting channels. Remove and retain hardware for re-assembly in Step 6.

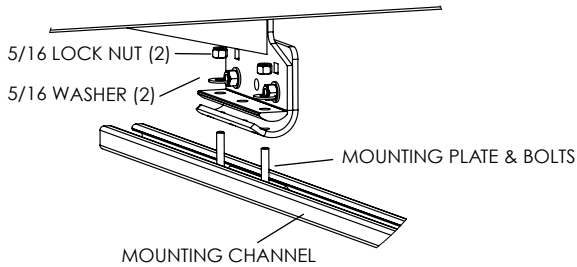

Using (2) 5/16x3/4" carriage bolt, (2) 5/16" washer and (2) 5/16" nylon lock nut per drop down mechanism, install each drop down mechanism to each cross members. The end of the bottom bracket on the drop down mechanism should line up with the end of the cross member. Torque nuts to 10 ft-lbs.

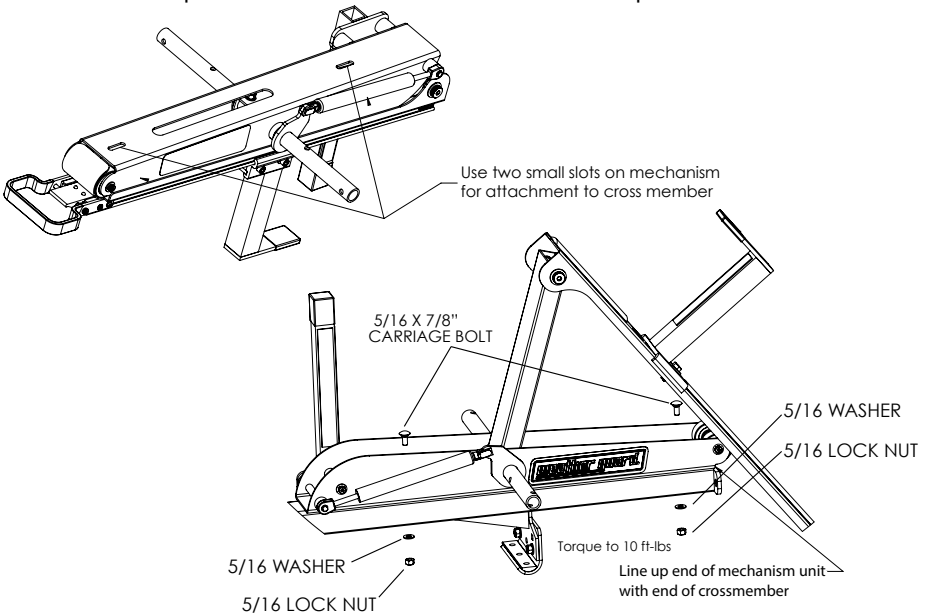

STEP 6 - MOUNT REAR CROSSMEMBER TO VEHICLE

Most vans will use a mounting channel kit for installing the EZGLIDE2™ van rack. Follow STEP 6A for these applications. For gutter mounting, follow STEP 6B.

STEP 6A - MOUNTING CHANNEL APPLICATIONS

Insert (2) 5/16-18x1-1/4" carriage bolts into each mounting plate. Position mounting plate assemblies into channel in the approximate location of the cross member before inserting the roof mounting bolts and attaching the mounting channels to the van roof.

Using (2) 5/16" washers, (2) 5/16" nylon lock nuts, and (1) mounting foot bolt plate foot, install the rear cross member on the mounting channel. The cross member that has the slide down

rear position.

The EZ GLIDE2 can be installed on either the street side or curb side of the van. Decide which side to install the drop-down before mounting it to the vehicle.

Locate the cross member approximately 1-3" from the end of the mounting channel and hand tighten each 5/16" nut. The nuts will need to be kept loose until step 7 is complete.

MOUNTING PLATE

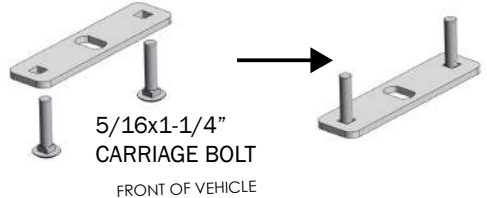

ATTACH MOUNTING CHANNEL TO VAN AFTER POSITIONING MOUNTING PLATES

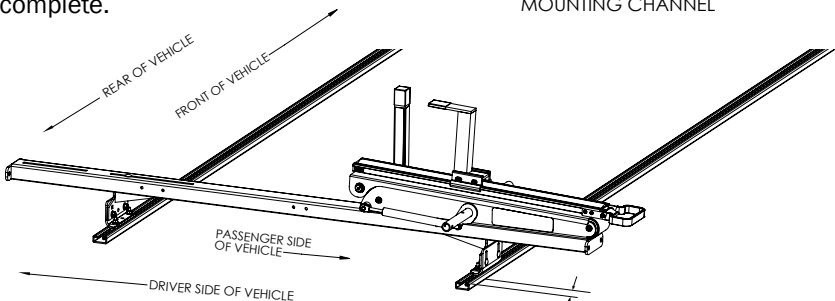
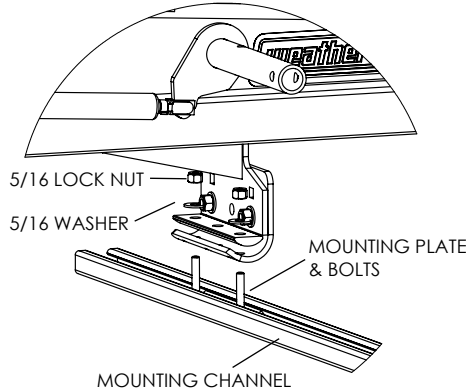
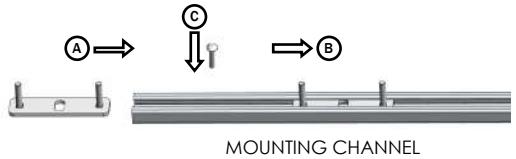

IT IS RECOMMENDED THAT THE REAR CROSSMEMBER BE LOCATED APPROXIMATELY 1-3" FROM THE REAR OF THE MOUNTING CHANNEL

STEP 6B - GUTTER MOUNTING APPLICATIONS

Place rear crossmember on vehicle near the rear of the van into the mounting gutter and position the universal mounting clamp around the outer edge of the gutter. Do not tighten at this time to allow flexibility while installing the connecting tubes.

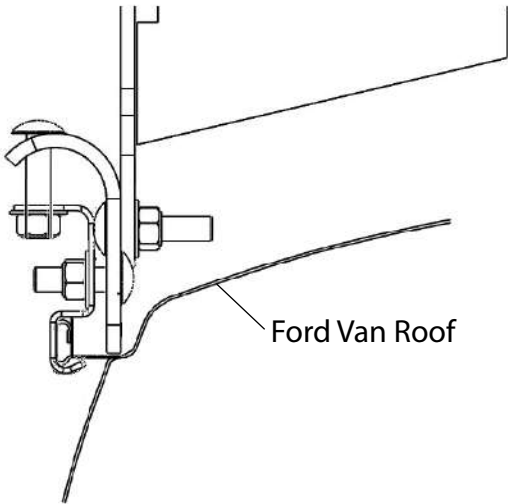
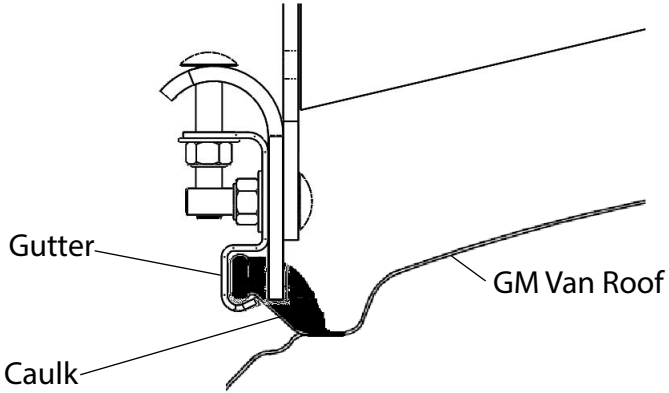

STEP 7 - INSTALL CENTER CONNECTING TUBE

Select the connecting tube, 89", 70" or 36" long that best fits your van and the load you are carrying. 130" WB Transit vans should use a 70" tube.

Rotate and position the connecting tube on the drive tube until all 4 mounting holes line up. Using (2) 5/16x1-3/4" bolts, (4) 5/16" washers, and (2) 5/16" nuts, install the connecting tube. Torque 5/16 nuts to 10 ft-lbs.

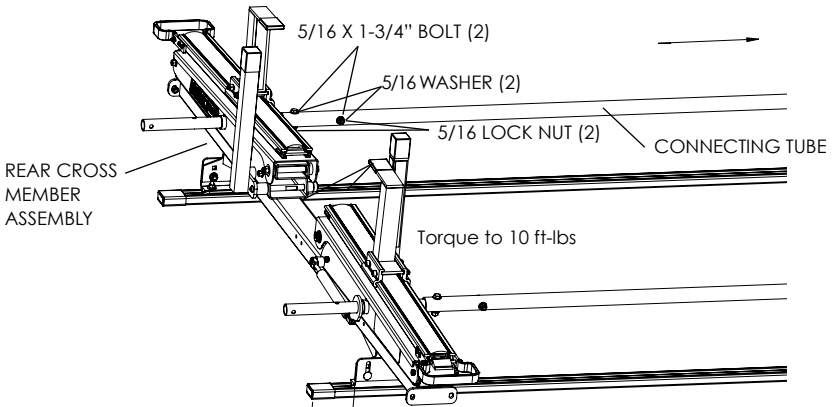

Using (2) 5/16x1-3/4" bolts, (4) 5/16" washers, and (2) 5/16" nuts, install the connecting tube on the front drive tube. Rotate and position the center connecting tube until all 4 mounting holes line up and then drop cross member onto stud plates. Torque 5/16 nuts to 10 ft-lbs.

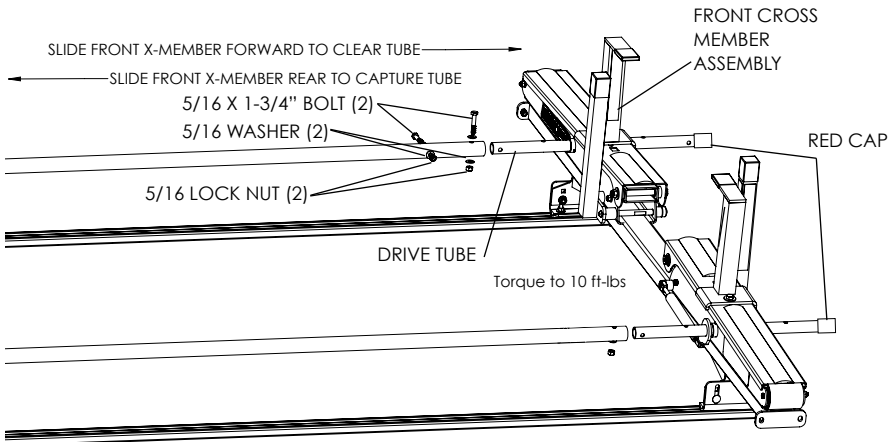

STEP 8 - INSTALL REAR DRIVE TUBE

Using (2) 5/16x1-3/4" bolts, (4) 5/16" washers, and (2) 5/16" nylon lock nuts, install the drive tube to the rear drop down mechanism. Rotate and position tube until all 4 mounting holes line up and torque nuts to 10 ft-lbs.

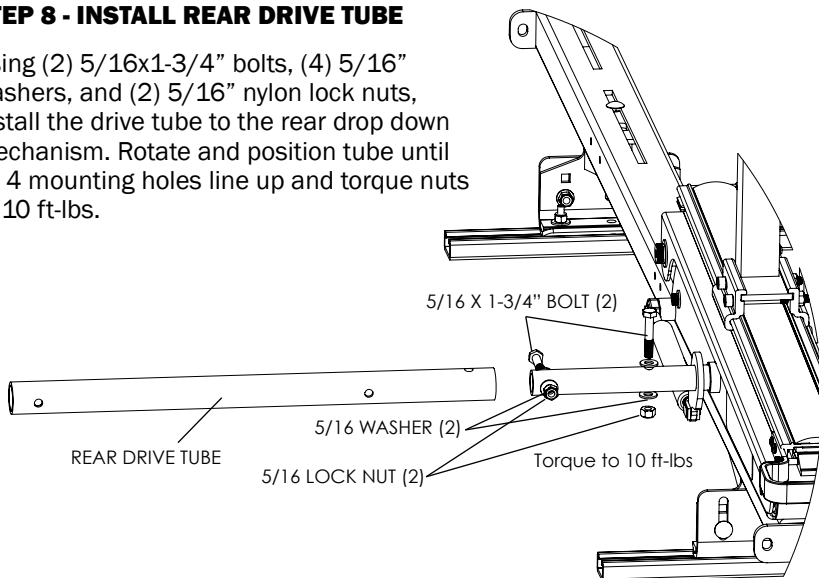

STEP 9 - INSTALL REAR COUPLING

Install the rear coupling to the drive tube using the coupling bushing and clevis pin. The coupling should be installed with the red cap on top and the open end pointing AWAY from the center of the van.

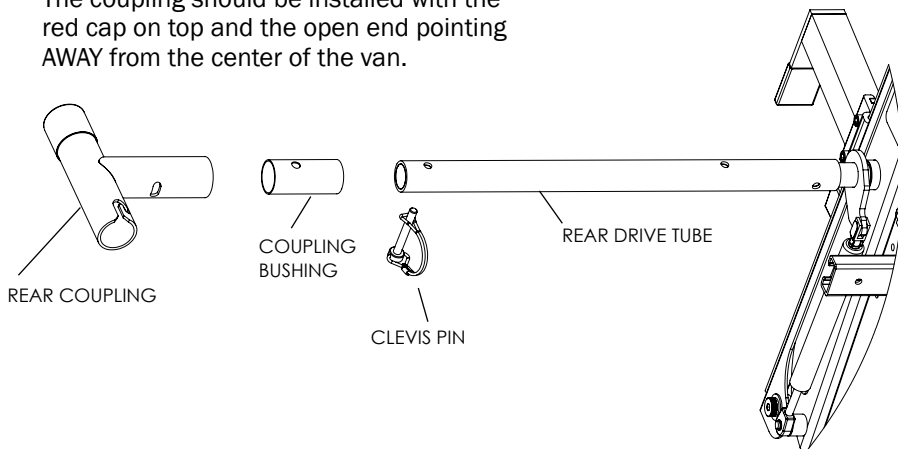

STEP 10 - POSITION AND SECURE LADDER RACK ASSEMBLY

clearance between the back of the vehicle and the handle for full rotation. If more or less clearance is desired slide the rack forward or backwards in the mounting channels. Once the desired position is found, torque all 5/16" nuts to 10 ft-lbs to lock the position of the rack.

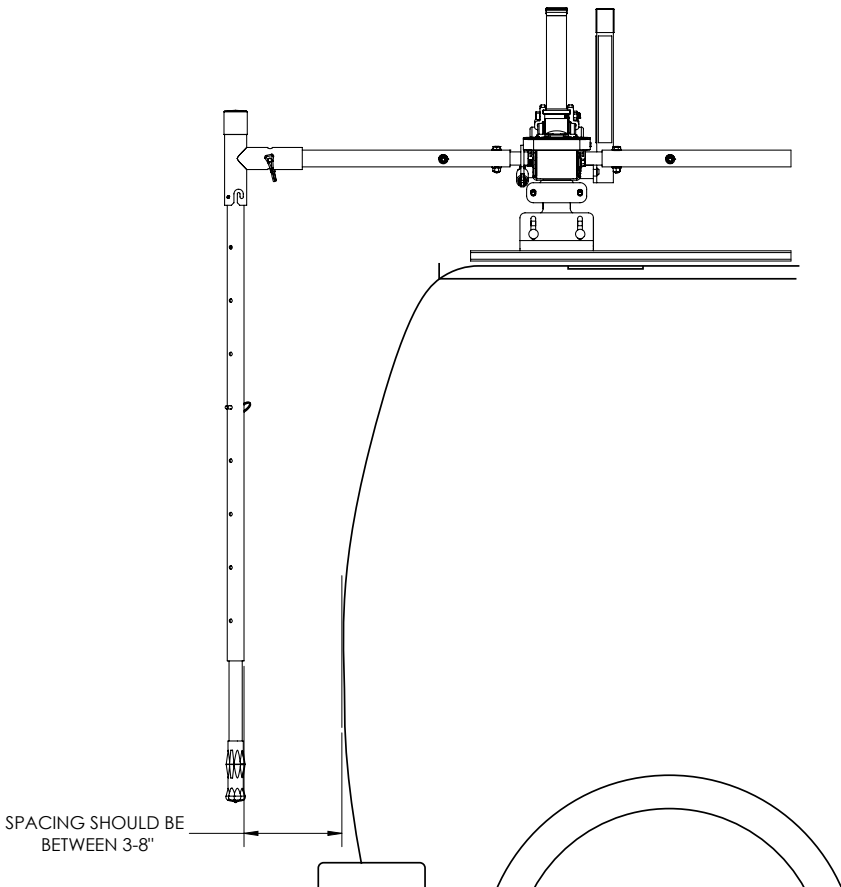

STEP 11 - ADJUST LADDER HOOKS

Measure width of ladder where it will rest on the hook. Loosen the 5/16-18 set bolt with 1/2" wrench and move the sliding part of the ladder hook in or out to best fit the ladder.

Test fit the ladder on the hook. Make and final adjustments and tighten the 5/16 bolt to 10 ft-lbs.

The adjustable ladder hook can be set from 5" to 9-1/4" widths. The welded loop on the fixed section of the hook provides a fastening point for cables to secure ladders to the rack.

Do not exceed the van manufacturer's maximum roof load rating. This information is available from OEM's body bulder website.

Like any roof load, ladders should be evenly distributed between the cross-members.

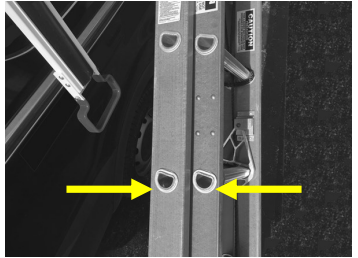

2265-3-01 & 2267-3-01 EZGLIDE²™ SERVICE PARTS

PART NO	DESCRIPTION	FITS MODEL NUMBER
70512	REPLACEMENT 70" CONNECTING TUBE FOR EZGLIDE ² ™ DROP-DOWN VAN RACK	2261-3-01, 2265-3-01
70513	REPLACEMENT 36" CONNECTING TUBE FOR EZGLIDE ² ™ DROP-DOWN VAN RACK	2267-3-01, 2265-3-01, 2267-3-01
70514	REPLACEMENT LADDER STOP KIT FOR EZGLIDE ² ™ DROP-DOWN VAN RACK	ALL MODELS
70546	REPLACEMENT ADJUSTABLE LADDER HOOK KIT FOR EZGLIDE ² ™ FIXED DROP-DOWN MECHANISM	ALL MODELS
70517	REPLACEMENT BOLT KIT FOR MOUNTING CHANNEL KIT, 85 IN	2085-0-01
70520	REPLACEMENT RED PLASTIC CAP KIT FOR EZGLIDE ² ™ DROP-DOWN VAN RACK	ALL MODELS
70521	REPLACEMENT REAR HANDLE KIT FOR EZGLIDE ² ™ DROP-DOWN VAN RACK	ALL MODELS
70522	REPLACEMENT RUB STRIP KIT FOR EZGLIDE ² ™ FIXED DROP-DOWN MECHANISM	ALL MODELS
70524	REPLACEMENT DAMPER FOR EZGLIDE ² ™ DROP-DOWN VAN RACK	ALL MODELS
70528	REPLACEMENT BOLT KIT FOR MODEL 2271-3-01 EZGLIDE ² ™ DROP-DOWN VAN RACK	2271-3-01, 2261-3-01
70529	REPLACEMENT BOLT KIT FOR MODEL 2275-3-01 EZGLIDE ² ™ DROP-DOWN VAN RACK	2275-3-01, 2265-3-01
70530	REPLACEMENT BOLT KIT FOR MODEL 2277-3-01 EZGLIDE ² ™ DROP-DOWN VAN RACK	2277-3-01, 2267-3-01
70532	REPLACEMENT EZGLIDE ² ™ FIXED DROP-DOWN MECHANISM	ALL MODELS
70533	REPLACEMENT BUSHING KIT FOR EZGLIDE ² ™ DROP-DOWN VAN RACK	ALL MODELS