



**VAN SOLUTIONS**  
FOR THE WAY YOU WORK™

**EZGlide2™**

# INSTALLATION MANUAL



**Model 2271-3-01**



**ATTENTION: PLEASE READ AND UNDERSTAND ALL INSTRUCTIONS AND WARNINGS BEFORE ASSEMBLING, INSTALLING OR USING THIS PRODUCT.**

**CAUTION**

Be safe - always wear protective eye wear to keep debris out of your eyes when installing WEATHER GUARD® Van Products

**WARNING**

Prior to drilling, check under vehicle for fuel, tanks, fuel lines, brake lines, electric wires, etc. To avoid cutting or puncturing them. Do not use Blind Fasteners in these areas.

**Tools Needed**

- THREADLOCKER COMPOUND
- 1/2" SOCKET AND/OR WRENCH
- 3/16" HEX KEY/DRIVER
- 1/4" HEX KEY/DRIVER
- 2X 9/16 SOCKET AND/OR WRENCH
- 7/16" SOCKET AND/OR WRENCH
- SAW RECOMMENDED FOR RAM PROMASTER 118" WHEELBASE
- DRILL WITH 21/64" DRILL BIT RECOMMENDED FOR RAM PROMASTER 118" WHEEBASE
- TORQUE SETTABLE DRIVER OR TORQUE WRENCH.
- 3/8" OPEN END WRENCH

**BEFORE YOU BEGIN**

The EZGLIDE2™ drop-down ladder rack is designed to work with OEM side gutters or with Weather Guard Mounting Channel kits to provide the best support for your ladders and to take advantage of OEM provided roof mounting points. If you have not already installed the mounting channel kit to the van roof, install it now before proceeding.

If you are installing this product on a van with OEM side gutters, you do not need to use a mounting channel kit.

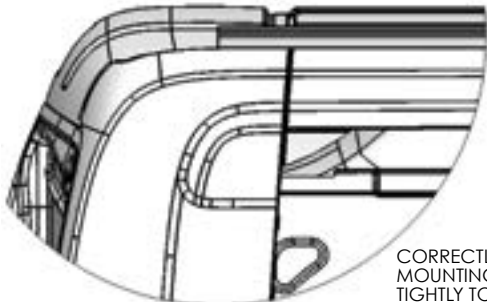

CORRECTLY INSTALLED MOUNTING CHANNELS FIT TIGHTLY TO THE VAN ROOF.

**CONTENTS**

**EZGLIDE2 PARTS LIST ..... 4**

**STEP 1 INSTALL VERTICAL TUBE AND DAMPER ..... 6**

**STEP 2 INSTALL LADDER HOOKS ..... 7**

**STEP 3 MOUNT MOUNTING FEET TO CROSS MEMBERS ..... 8**

**STEP 4 INSTALL CURVED MOUNTING BRACKETS ..... 9**

**STEP 4B INSTALL CURVED MOUNTING BRACKETS, GUTTER MOUNT..... 10**

**STEP 5 INSTALL DROP DOWN MECHANISMS TO CROSS MEMBERS..... 11**

**STEP 6 MOUNT REAR CROSS MEMBERS TO VEHICLE..... 12**

**STEP 6B MOUNT CROSS MEMBERS TO VEHICLE, GUTTER MOUNT..... 13**

**STEP 7 INSTALL CENTER CONNECTING TUBE AND FRONT CROSS MEMBER ..... 14**

**STEP 8 INSTALL REAR DRIVE TUBE ..... 15**

**STEP 9 INSTALL REAR COUPLING..... 15**

**STEP 10 POSITION AND SECURE LADDER RACK ASSEMBLY..... 16**

**STEP 11 INSTALL ACCESSORY VERTICAL LADDER STOPS ..... 16**

**EZGLIDE2™ SPARE PARTS LIST .....17**

**EZ GLIDE2 PARTS LIST**

DESCRIPTION	QTY
FIXED DROP DOWN	2
89" CONNECTING TUBE	1
36" CONNECTING TUBE	1
REAR DRIVE TUBE	1
REAR COUPLING	1
MOUNTING FOOT	4
VERTICAL LADDER STOP	4
DAMPER	2
TELESCOPIC HANDLE	1
70" CROSS-MEMBER	2
FIXED LADDER HOOK	2

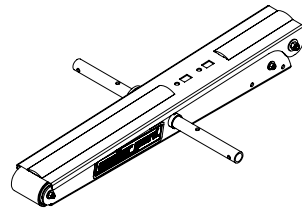

FIXED DROP DOWN

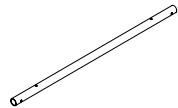

36" CONNECTING TUBE

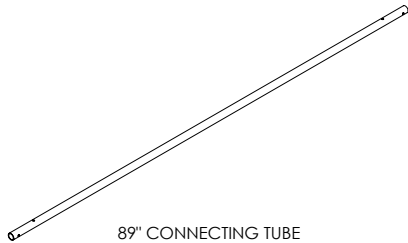

89" CONNECTING TUBE



REAR DRIVE TUBE

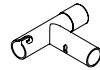

REAR COUPLING



MOUNTING FOOT

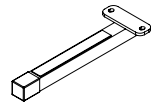

VERTICAL LADDER STOP

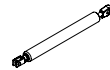

DAMPER

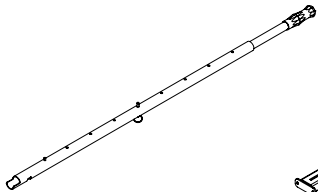

TELESCOPING HANDLE

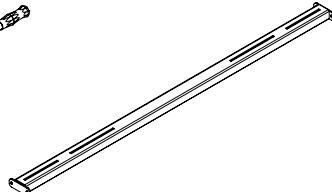

70" CROSSMEMBER

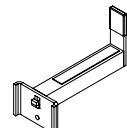

FIXED LADDER HOOK

DESCRIPTION	QTY
5/16" WASHER	54
5/16 x 1-3/4" BOLT	6
5/16 x 2" SCREW	8
RED CAP	1
1" SPACER	4
5/16 NYLON LOCK NUT	44
3/8 WASHER	4
3/8 x 7/8" BOLT	2
3/8 NYLON LOCK NUT	2
STUD PLATE	4
COUPLING BUSHING	1
CLEVIS PIN	1
5/16 x 3/4" CARRIAGE BOLT	16
E-CLIP	2
DAMPER ROD	2
UNIVERSAL CLAMP	4
LOOP CLAMP	1
SPRING CLIP	2
5/16 x 1-1/4" BOLT	8
CURVED MOUNTING BRACKET	4
MOUNTING FOOT BOLT PLATE	4

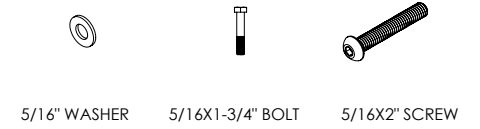

5/16" WASHER 5/16X1-3/4" BOLT 5/16X2" SCREW

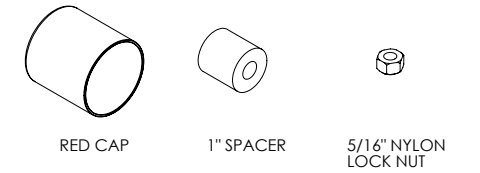

RED CAP 1" SPACER 5/16" NYLON LOCK NUT

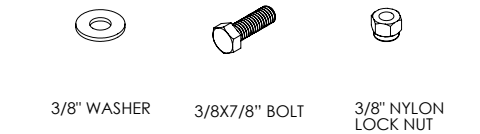

3/8" WASHER 3/8X7/8" BOLT 3/8" NYLON LOCK NUT

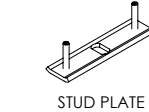

STUD PLATE

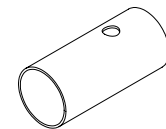

COUPLING BUSHING



CLEVIS PIN



5/16X3/4" CARRIAGE BOLT



E-CLIP

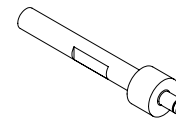

DAMPER ROD



UNIVERSAL CLAMP



LOOP CLAMP



SPRING CLIP



5/16X1-1/4" BOLT

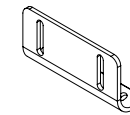

CURVED MOUNTING BRACKET

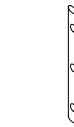

MOUNTING FOOT BOLT PLATE

**STEP 1 - INSTALL VERTICAL TUBE AND DAMPER**

Using the damper, damper rod and 1-e-clip, install the eyelet end of the damper to the damper rod using 1-e-clip. The damper comes with a preinstalled clip on the clevis end side. Remove clip, slide clevis end over the drive tube cam, and reinstall clip.

Using 2-5/16x2" screws, 2-1" spacers, 1-5/16" nylon lock nut, 1-5/16" washer, and 1-damper rod, install the vertical ladder stop to each drop down unit. The inner mounting point will use the 5/16" washer and nut, while the outer mounting point will use the damper rod for the 5/16x2" screw. It is recommended to use thread locking compound on the 5/16x2" screw that threads into the damper rod. Torque both the 5/16" nut and damper rod to 17 ft-lbs. Hold flat spots on damper rod with a 3/8" open end wrench while tightening.

Repeat with the other drop down unit.

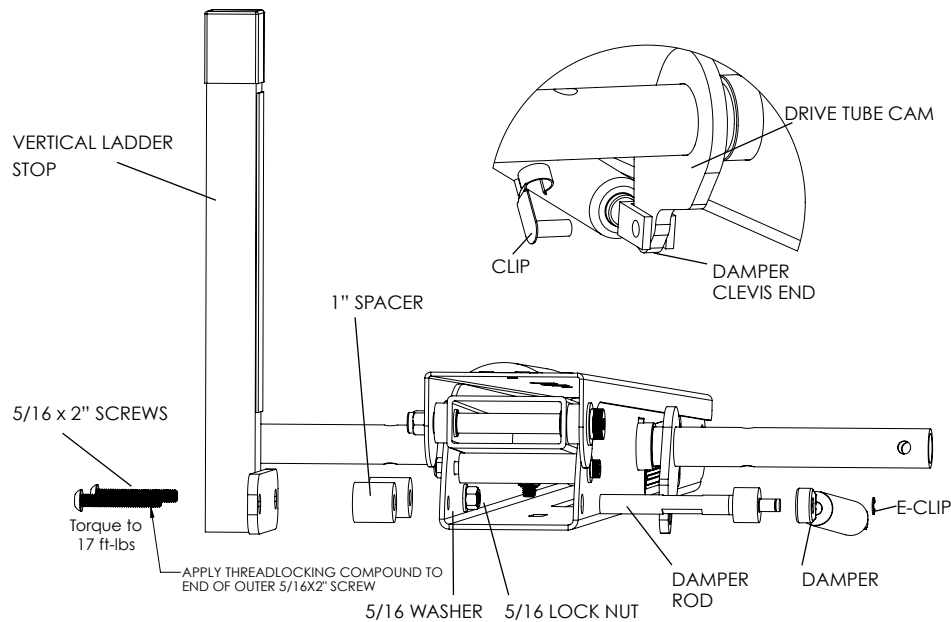

**STEP 2 - INSTALL LADDER HOOKS**

Using 1-3/8x7/8" bolt, 1-3/8" nylon lock nut, and 2-3/8" washers install the fixed ladder hook to the drop down unit. The hook should be located according to the diagram in the upper set of holes, but may be adjusted depending on ladder dimensions and user preference. Torque nut to 30 ft-lbs.

Repeat for second drop down unit.

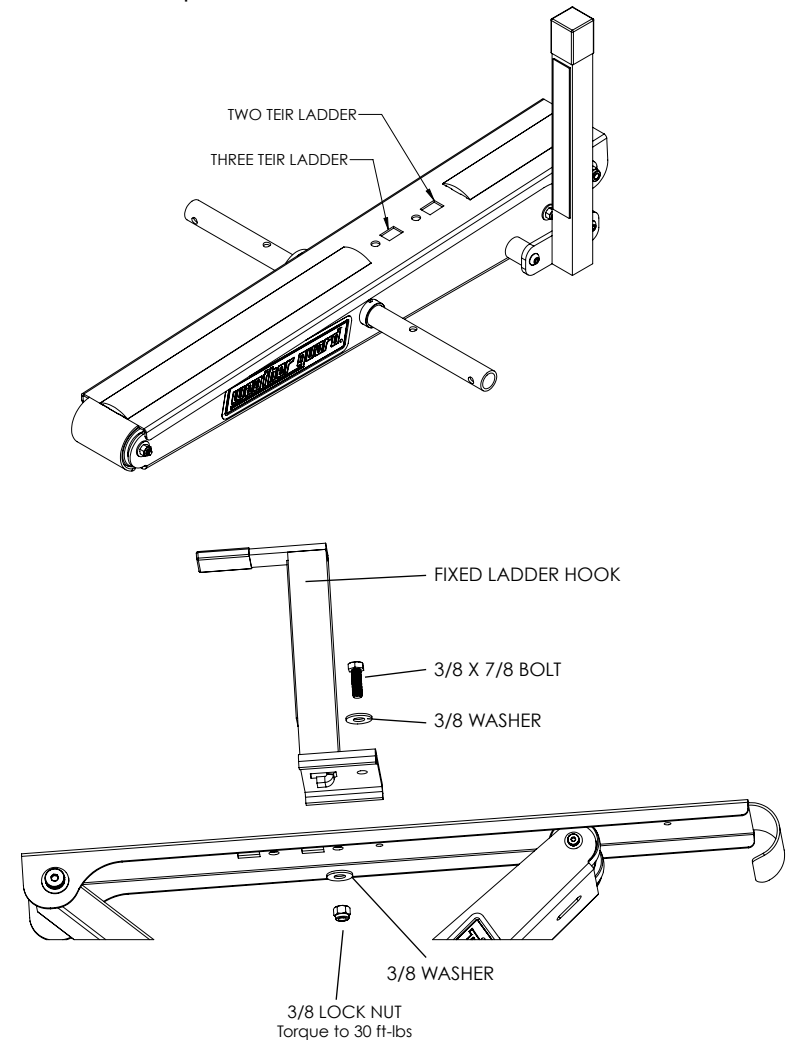

**STEP 3 - MOUNT MOUNTING FEET TO CROSS MEMBERS**

Only use one carriage bolt, washer, and nut per mounting foot.

Using 1-5/16x3/4" carriage bolt, 1-5/16" washer, and 1-5/16" nylon lock nut per mounting foot, install two mounting feet per cross member. Please refer to the table and diagram for mounting foot location and orientation.

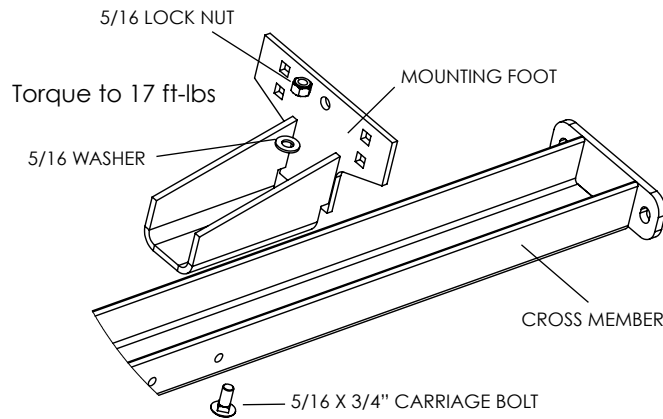

INSTALL MOUNTING FEET ACCORDING TO TABLE

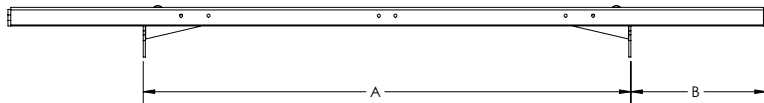

MOUNTING FOOT DISTANCE			
VEHICLE	DIM "A"		DIM "B"
FORD TRANSIT CONNECT (LOW-ROOF)	55-1/2"		6-3/4"
NISSAN NV	59-3/8"		4-13/16"
GMC SAVANNA*	F: 58-7/8"	R: 57-7/8"	F: 5-1/16" R: 5-5/8"
CHEVY EXPRESS*	F: 58-7/8"	R: 57-7/8"	F: 5-1/16" R: 5-5/8"
FORD E-SERIES*	F: 62-7/8"	R: 60-3/4"	F: 3-1/16" R: 4-1/8"

\*Due to the curvature of the gutter on each van, the dimensions given are a reference point. Please make appropriate adjustments to ensure a tight and secure fit, with the cross member centered on the width of the van.

**STEP 4 - INSTALL CURVED MOUNTING BRACKETS**

Using 2-5/16x3/4" carriage bolt, 2-5/16" washer, and 2-5/16" nylon lock nut per mounting foot install a curved mounting bracket to each mounting foot. Torque nuts to 17 ft-lbs.

If using an impact driver to torque nuts, it is recommended that the carriage bolt orientation be reversed to engage the square cut outs in the mounting foot.

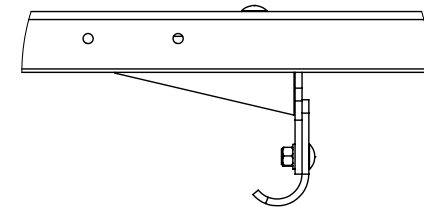
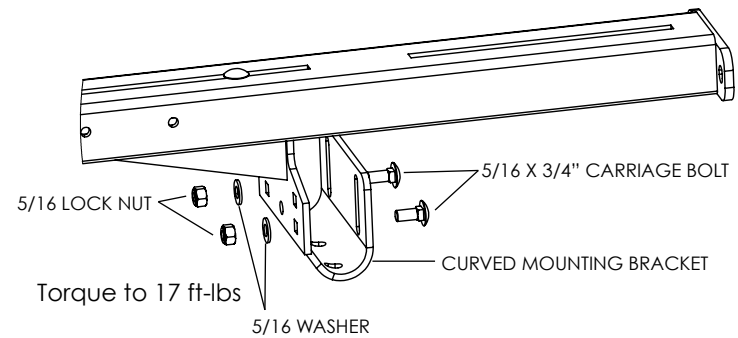

Most vehicle installations will benefit from having the lowest installed height with the mounting bracket lining up with the start of the curve on the curved mounting bracket. Due to vehicle roof curvatures some adjustment for final assembly height may be required after the crossmembers are installed on the roof.

**STEP 4B - INSTALL CURVED MOUNTING BRACKETS, GUTTER MOUNT**

Using the dimensions shown below, mark a drill point on the curved mounting bracket. Use a 7/16" drill bit to drill a through hole.

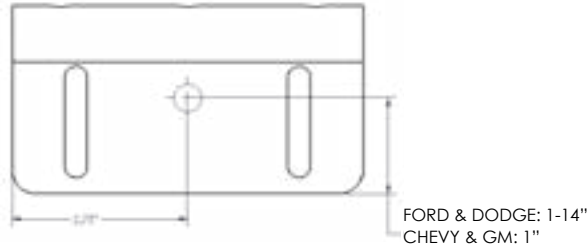

Using 2-5/16x3/4" carriage bolt, 2-5/16" washer, and 2-5/16" nylon lock nut per mounting foot install a curved mounting bracket to each mounting foot. Torque nuts to 17 ft-lbs.

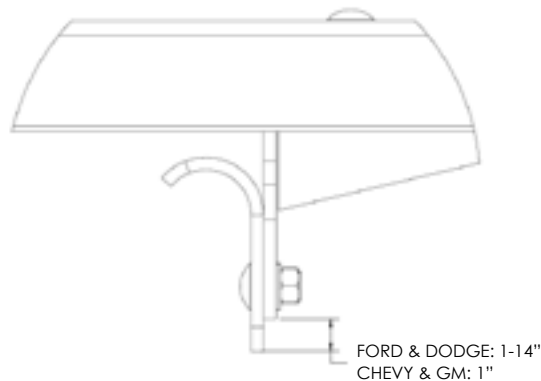
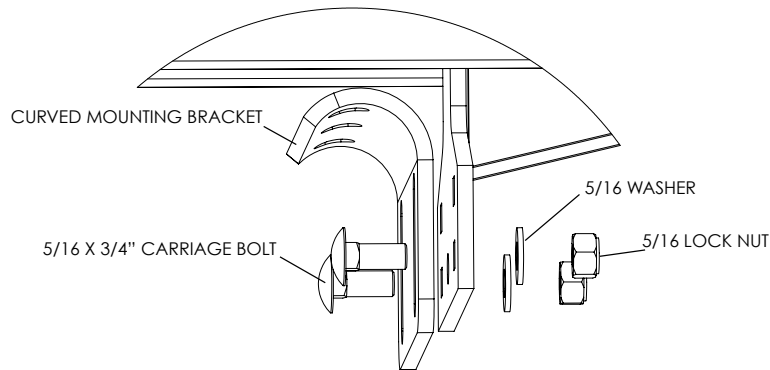

**STEP 5 - INSTALL DROP DOWN MECHANISMS TO CROSS MEMBERS**

Using 2-5/16x3/4" carriage bolt, 2-5/16" washer, and 2-5/16" nylon lock nut per drop down mechanism, install each drop down mechanism to the cross members. The end of the bottom bracket on the drop down mechanism should line up with the end of the cross member. Torque nuts to 17 ft-lbs.

On single side installations, there will be one drop down mechanism per cross member. On dual drop down setups, you may install two mechanisms per cross member.

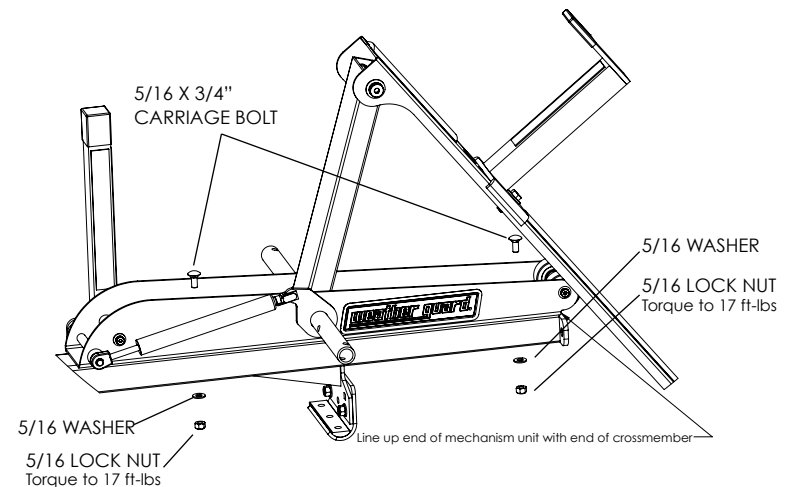
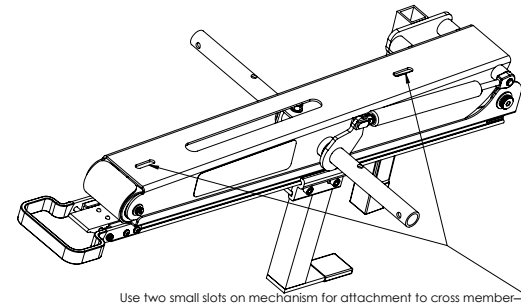
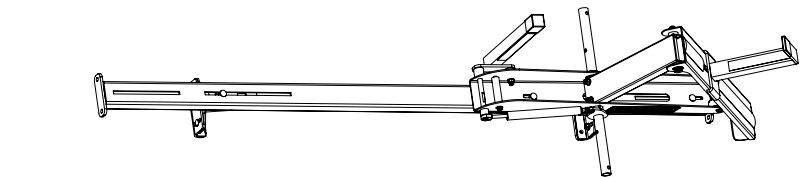



## STEP 6 - MOUNT REAR CROSS MEMBERS TO VEHICLE

Slide two stud plates per mounting channel into mounting channel if not already done. If installing a dual setup with 3 cross members, 3 stud plates will be used per mounting channel. Using 2-5/16" washers, 2-5/16-18" nylon lock nuts, and 1 mounting foot bolt plate per mounting foot, install the rear cross member on the mounting channel. The cross member that has the slide down mechanism should be installed in the rear position.

The EZ GLIDE2 can be installed on either the street side or curb side of the van. Decide which side to install the drop-down before mounting it to the vehicle.

Locate the cross member approximately 1-3" from the end of the mounting channel and hand tighten each 5/16-18" nut. The 5/16-18" nuts will need to be kept loose until step 7 is complete.

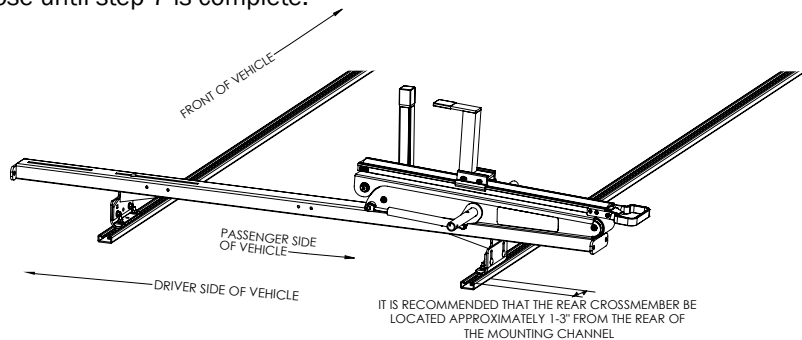
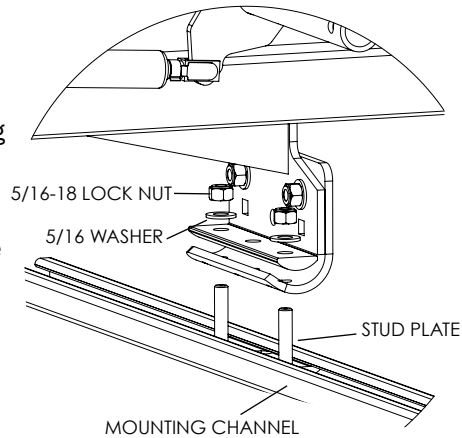

On some van installations it is necessary to place the curved mounting bracket on top of the mounting channel end caps and pinch them to the mounting channel. It may also be necessary to slit the end cap so the 5/16-18" stud bolts align with the holes in the mounting bracket.

## STEP 6B - MOUNT CROSS MEMBERS TO VEHICLE, GUTTER MOUNT

On vehicles that include a rain gutter, such as the Ford Econoline, Chevrolet Express, and GMC Savana vans, mounting channels are not required. Using 2-5/16x3/4" carriage bolt, 2-5/16" washer, and 2-5/16" nylon lock nut per mounting foot install a curved mounting bracket to each mounting foot as shown in the diagram. Torque nuts to 17 ft-lbs

Set the inverted curved mounting bracket into the gutter, and using 1- universal clamp, 1- 5/16x1-1/4" carriage bolt, 1- 5/16" washer, and 1-5/16 nylon lock nut, clamp the universal onto the gutter as shown in the diagram. Torque nut to 10 ft-lbs. After fully tightened, use 1- 5/16x1-1/4" carriage bolt, 1- 5/16" washer, and 1-5/16 nylon lock nut to connecting the universal clamp through the curved mounting bracket and mounting foot. Hand tighten each 5/16" nut, as these will need to be kept loose until Step 7 is complete.

On Chevy Express and GMC Savanna installations, the vertical 5/16-18 bolt, nut and washer are not used.

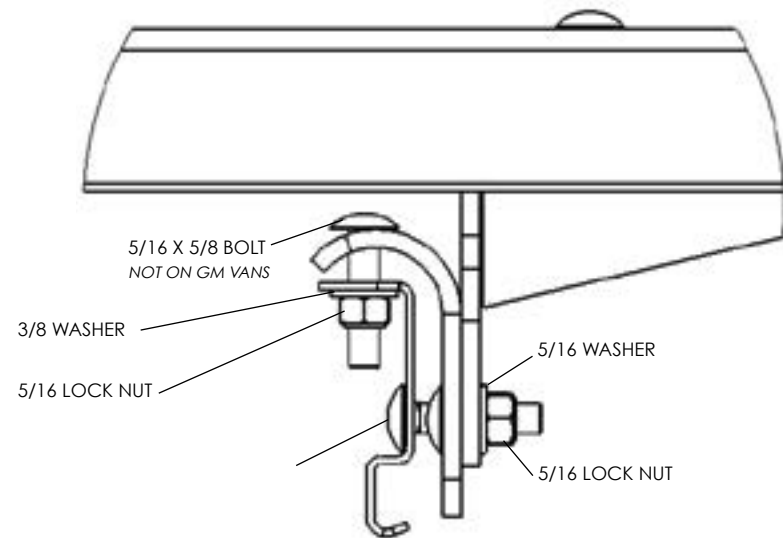

**STEP 7 - INSTALL CENTER CONNECTING TUBE AND FRONT CROSS MEMBER**

Rotate and position the connecting tube on the drive tube until all 4 mounting holes line up. Using 2-5/16x1-3/4" bolts, 4-5/16" washers, and 2-5/16" nuts, install the connecting tube. Torque 5/16 nuts to 17 ft-lbs.

The 2271-3-01 ladder rack includes two connecting tubes. Use the shorter connecting tube for 5' to 8' step ladders or extension ladders up to 16'. Use the longer connecting tube for 10' to 12' step ladders or 20' to 40' extension ladders.

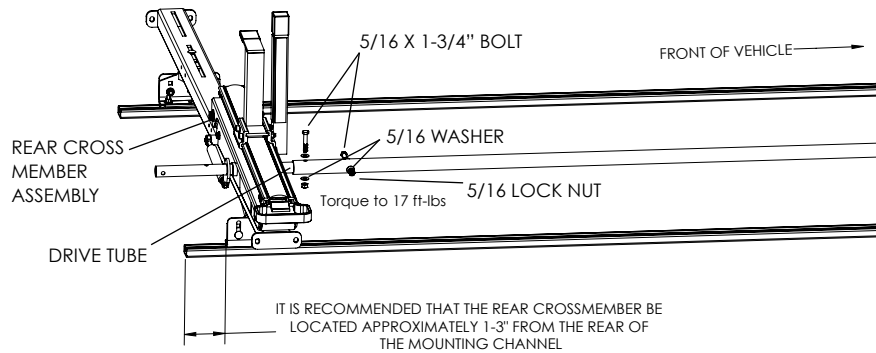

Using 2-5/16x1-3/4" bolts, 4-5/16" washers, and 2-5/16" nuts, install the connecting tube on the front drive tube. Rotate and position the center connecting tube until all 4 mounting holes line up and then drop cross member onto stud plates. Torque 5/16 nuts to 17 ft-lbs.

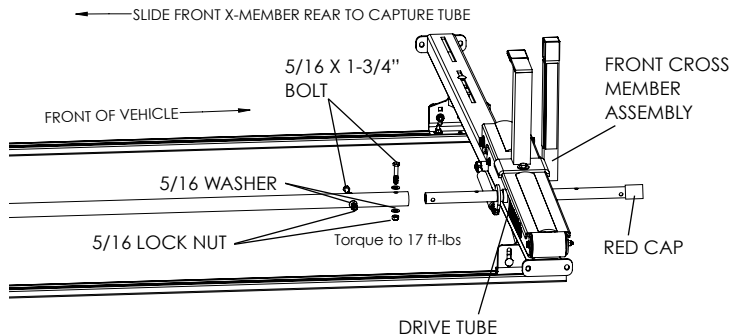

On Ford Transit installations it is ok to place the curved mounting bracket on top of the mounting channel end caps and pinch them to the mounting channels.

**STEP 8 - INSTALL REAR DRIVE TUBE**

Using 2-5/16x1-3/4" bolts, 4-5/16" washers, and 2-5/16" nylon lock nuts, install the drive tube to the rear drop down mechanism. Rotate and position tube until all 4 mounting holes line up and torque nuts to 17 ft-lbs.

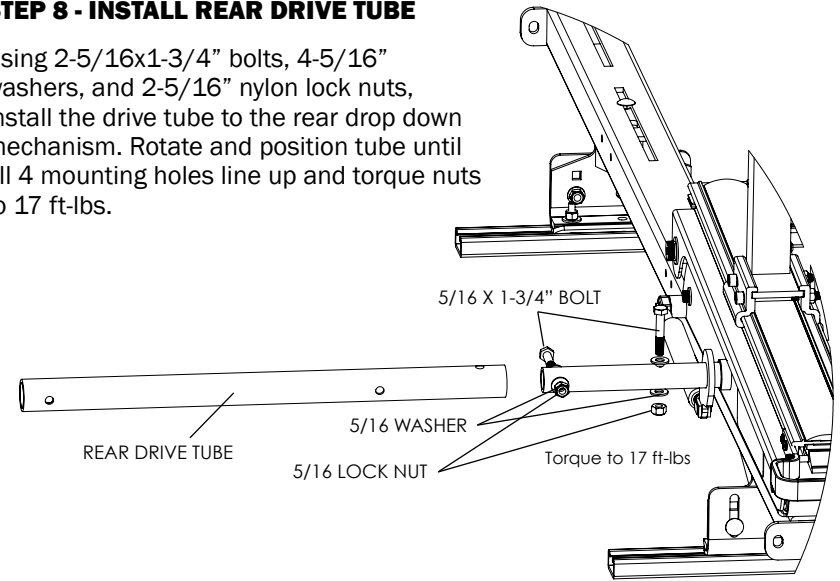

**STEP 9 - INSTALL REAR COUPLING**

Install the rear coupling to the drive tube using the coupling bushing and clevis pin. The coupling should be installed with the red cap on top and the open end pointing AWAY from the center of the van.

The rear coupling may fit too tightly when first assembled. If it sticks, rotate it a couple times until it moves freely.

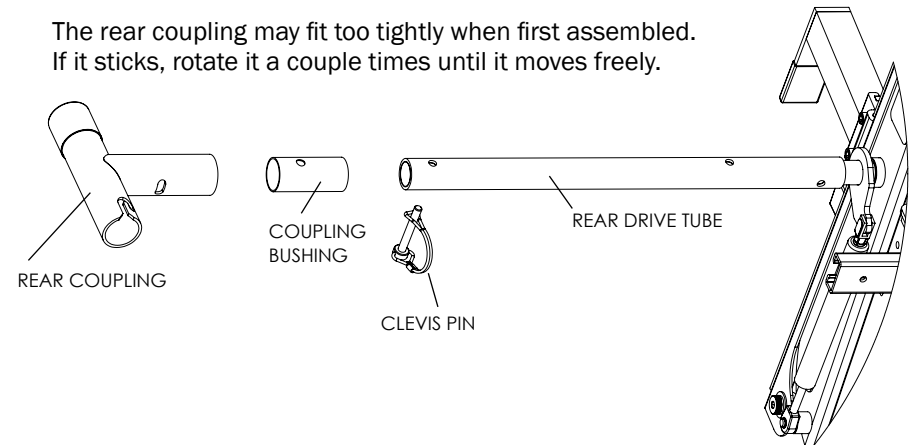





### STEP 10 - POSITION AND SECURE LADDER RACK ASSEMBLY

Insert the handle into the rear coupler and ensure there is sufficient clearance between the back of the vehicle and the handle for full rotation. If more or less clearance is desired slide the rack forward or backwards in the mounting channels. Once the desired position is found, torque all 5/16-18" nuts to 17 ft-lbs to lock the position of the rack. For gutter mount installations, please torque each 5/16-18" nut to 17 ft-lbs.

For Ford and Dodge applications, install 1-5/16X1-1/4" carriage bolt, 1- 5/16 washer, and 1-5/16" lock nut, in the horizontal position as shown in the 4b diagram and torque each nut to 17 ft-lbs.

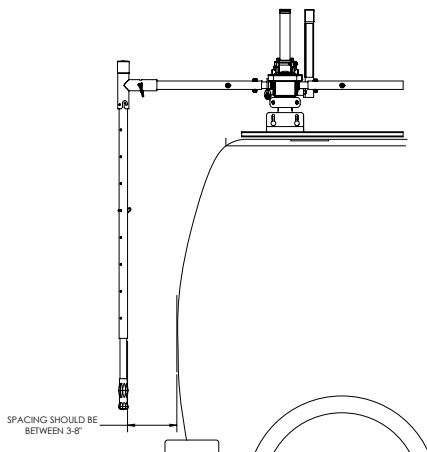

### STEP 11 - INSTALL VERTICAL LADDER STOPS

Using 2-5/16x1-1/4" bolts, 4- 5/16" washers, and 2-5/16" nylon lock nuts per vertical ladder stop, install 1 vertical ladder stop at the end of each cross member. Torque nuts to 17 ft-lbs.

If a dual side setup was installed do not install the ladder stops.

Your drop down ladder rack also includes two spring clips that may be installed to the inside of the van, that allow the handle to be safely stored when the handle is not in use.

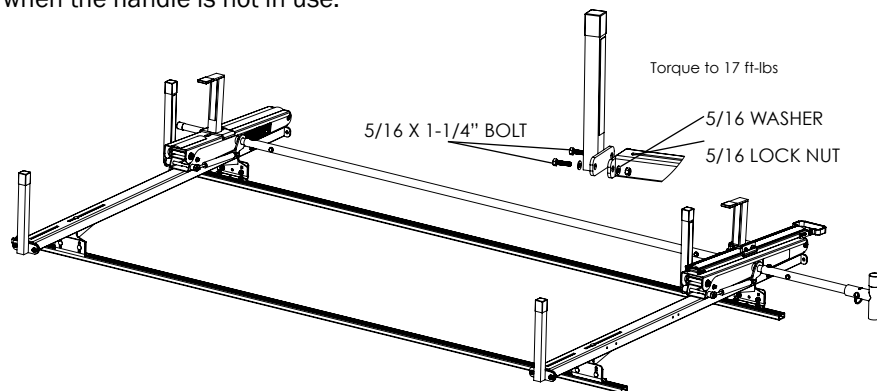

### 2271-3-01 EZGLIDE2™ SERVICE PARTS

PART NO	DESCRIPTION	FITS MODEL NUMBER
70511	REPLACEMENT 89" CONNECTING TUBE FOR EZGLIDE2™ DROP-DOWN VAN RACK	
70512	REPLACEMENT 70" CONNECTING TUBE FOR EZGLIDE2™ DROP-DOWN VAN RACK	
70513	REPLACEMENT 36" CONNECTING TUBE FOR EZGLIDE2™ DROP-DOWN VAN RACK	
70514	REPLACEMENT LADDER STOP KIT FOR EZGLIDE2™ DROP-DOWN VAN RACK	ALL MODELS
70515	REPLACEMENT LADDER HOOK KIT FOR EZGLIDE2™ FIXED DROP-DOWN MECHANISM	ALL MODELS
70517	REPLACEMENT BOLT KIT FOR MOUNTING CHANNEL KIT, 85 IN	2085-0-01
70518	REPLACEMENT BOLT KIT FOR MOUNTING CHANNEL KIT, 102 IN	2102-0-01
70519	REPLACEMENT BOLT KIT FOR MOUNTING CHANNEL KIT, 102 IN	2113-0-01
70520	REPLACEMENT RED PLASTIC CAP KIT FOR EZGLIDE2™ DROP-DOWN VAN RACK	ALL MODELS
70521	REPLACEMENT REAR HANDLE KIT FOR EZGLIDE2™ DROP-DOWN VAN RACK	ALL MODELS
70522	REPLACEMENT RUB STRIP KIT FOR EZGLIDE2™ FIXED DROP-DOWN MECHANISM	ALL MODELS
70524	REPLACEMENT DAMPER FOR EZGLIDE2™ DROP-DOWN VAN RACK	ALL MODELS
70528	REPLACEMENT BOLT KIT FOR MODEL 2271-3-01 EZGLIDE2™ DROP-DOWN VAN RACK	2271-3-01
70529	REPLACEMENT BOLT KIT FOR MODEL 2275-3-01 EZGLIDE2™ DROP-DOWN VAN RACK	2275-3-01,