



VAN SOLUTIONS
FOR THE WAY YOU WORK™

EZGlide2™

INSTALLATION MANUAL



Models 2265-3-01 & 2267-3-01



ATTENTION: PLEASE READ AND UNDERSTAND ALL INSTRUCTIONS AND WARNINGS BEFORE ASSEMBLING, INSTALLING OR USING THIS PRODUCT.

⚠ CAUTION

Be safe - always wear protective eye wear to keep debris out of your eyes when installing WEATHER GUARD® Van Products

⚠ WARNING

Prior to drilling, check under vehicle for fuel, tanks, fuel lines, brake lines, electric wires, etc. To avoid cutting or puncturing them. Do not use Blind Fasteners in these areas.

Tools Needed

- THREADLOCKER COMPOUND
- 1/2" SOCKET AND/OR WRENCH
- 3/16" HEX KEY/DRIVER
- 1/4" HEX KEY/DRIVER
- 2X 9/16 SOCKET AND/OR WRENCH
- 7/16" SOCKET AND/OR WRENCH
- SAW RECOMMENDED FOR RAM PROMASTER 118" WHEELBASE
- DRILL WITH 21/64" DRILL BIT RECOMMENDED FOR RAM PROMASTER 118" WHEELBASE
- TORQUE SETTABLE DRIVER OR TORQUE WRENCH.
- 3/8" OPEN END WRENCH

BEFORE YOU BEGIN

The best time to install the EZGLIDE2™ dual drop-down ladder rack when first installing the rack on the vehicle. After checking that your product is complete, follow along with the single drop-down installation instructions, adding the dual drop-down parts at the same time.

These instructions are written assuming that you are adding a dual-drop down kit to an existing installation.

CONTENTS

EZGLIDE2 PARTS LIST 4

STEP 1 INSTALL VERTICAL TUBE AND DAMPER 6

STEP 2 INSTALL LADDER HOOKS 7

STEP 3 MOUNT MOUNTING FEET TO CROSS MEMBERS 8

STEP 4 INSTALL CURVED MOUNTING BRACKETS 9

STEP 5 INSTALL DROP DOWN MECHANISMS TO CROSS MEMBERS..... 10

STEP 6 INSTALL CENTER CONNECTING TUBE 11

STEP 7 MOUNT CENTER CROSS MEMBERS TO VEHICLE..... 12

STEP 8 INSTALL CENTER CONNECTING TUBE 13

STEP 9 INSTALL REAR DRIVE TUBE 14

STEP 10 INSTALL REAR COUPLING..... 14

STEP 10 POSITION AND SECURE LADDER RACK ASSEMBLY 15

EZGLIDE2 SPARE PARTS LIST..... 16

EZ GLIDE2 PARTS LIST

DESCRIPTION	2265-3-0 QTY	2267-3-0 QTY
FIXED DROP DOWN	2	2
36" CONNECTING TUBE	-	1
70" CONNECTING TUBE	1	-
REAR DRIVE TUBE	1	1
REAR COUPLING	1	1
MOUNTING FOOT	-	2
VERTICAL LADDER STOP DAMPER	2	2
60" CROSS-MEMBER	-	1
FIXED LADDER HOOK	2	2

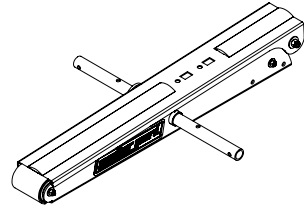

FIXED DROP DOWN

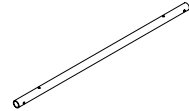

36" CONNECTING TUBE

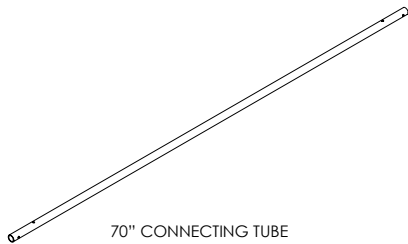

70" CONNECTING TUBE

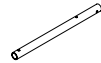

REAR DRIVE TUBE

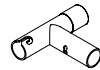

REAR COUPLING



MOUNTING FOOT

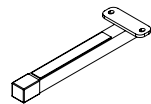

VERTICAL LADDER STOP

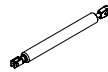

DAMPER

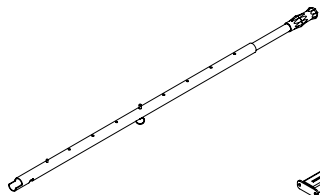

TELESCOPING HANDLE

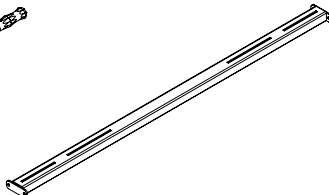

60" CROSSMEMBER

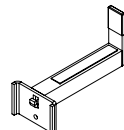

FIXED LADDER HOOK

DESCRIPTION	2265-3-0 QTY	2267-3-0 QTY
5/16" WASHER	18	36
5/16 x 1-3/4" BOLT	6	6
5/16 x 2" SCREW	4	4
RED CAP	1	1
1" SPACER	4	4
5/16 NYLON LOCK NUT	12	28
3/8 WASHER	4	4
3/8 x 7/8" BOLT	2	2
3/8 NYLON LOCK NUT	2	2
STUD PLATE	-	2
COUPLING BUSHING	1	1
CLEVIS PIN	1	1
5/16 x 3/4" CARRIAGE BOLT	-	10
E-CLIP	2	2
DAMPER ROD	2	2
5/16 x 1-1/4" CARRIAGE BOLT	-	4
UNIVERSAL CLAMP	-	-
5/16 x 1-1/4" BOLT	-	2
CURVED MOUNTING BRACKET	-	2
MOUNTING FOOT BOLT PLATE	-	2

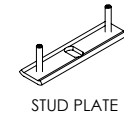
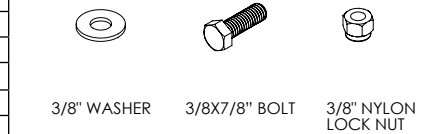
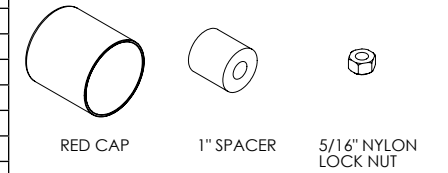
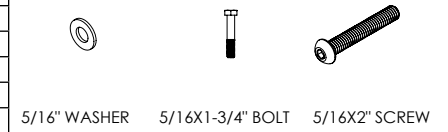

STUD PLATE

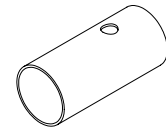

COUPLING BUSHING



CLEVIS PIN



5/16X3/4" CARRIAGE BOLT



E-CLIP

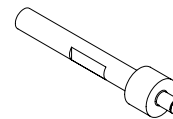

DAMPER ROD



UNIVERSAL CLAMP (NOT USED)



5/16 x 1-1/4" CARRIAGE BOLT



5/16X1-1/4" BOLT

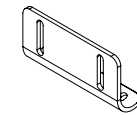

CURVED MOUNTING BRACKET

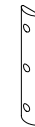

MOUNTING FOOT BOLT PLATE

STEP 1 - INSTALL VERTICAL TUBE AND DAMPER

Using the damper, damper rod and 1-e-clip, install the eyelet end of the damper to the damper rod using 1-e-clip. The damper comes with a preinstalled clip on the clevis end side. Remove clip, slide clevis end over the drive tube cam, and reinstall clip.

Using 2-5/16x2" screws, 2-1" spacers, 1-5/16" nylon lock nut, 1-5/16" washer, and 1-damper rod, install the vertical ladder stop to each drop down unit. The inner mounting point will use the 5/16" washer and nut, while the outer mounting point will use the damper rod for the 5/16x2" screw. It is recommended to use thread locking compound on the 5/16x2" screw that threads into the damper rod. Torque both the 5/16" nut and damper rod to 17 ft-lbs. Hold flat spots on damper rod with 3/8" open end wrench while tightening screws.

Repeat with the other drop down unit.

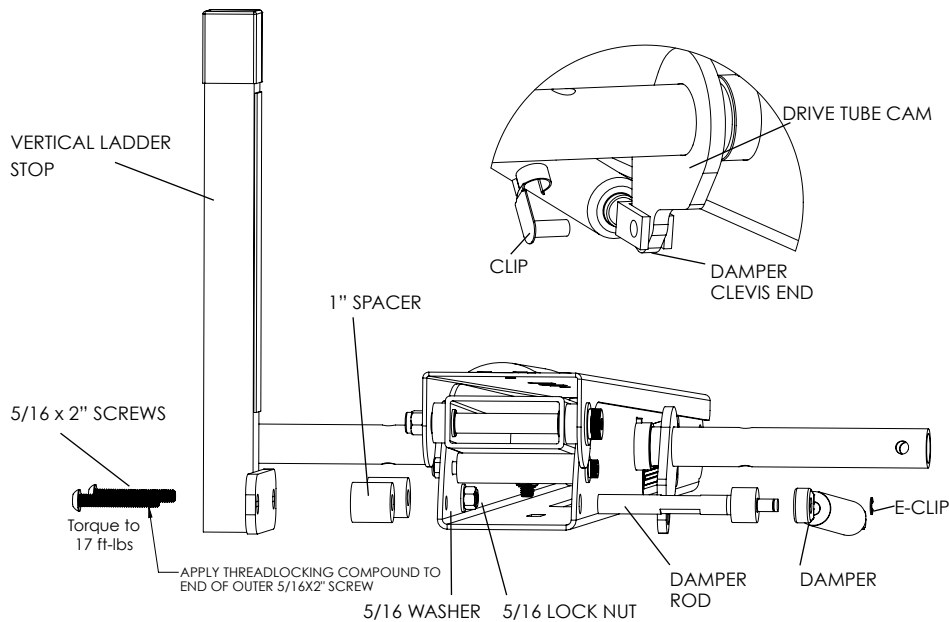

STEP 2 - INSTALL LADDER HOOKS

Using 1-3/8x7/8" bolt, 1-3/8" nylon lock nut, and 2-3/8" washers install the fixed ladder hook to the drop down unit. The hook should be located according to the diagram in the upper set of holes, but may be adjusted depending on ladder dimensions and user preference. Torque nut to 30 ft-lbs.

Repeat for second drop down unit.

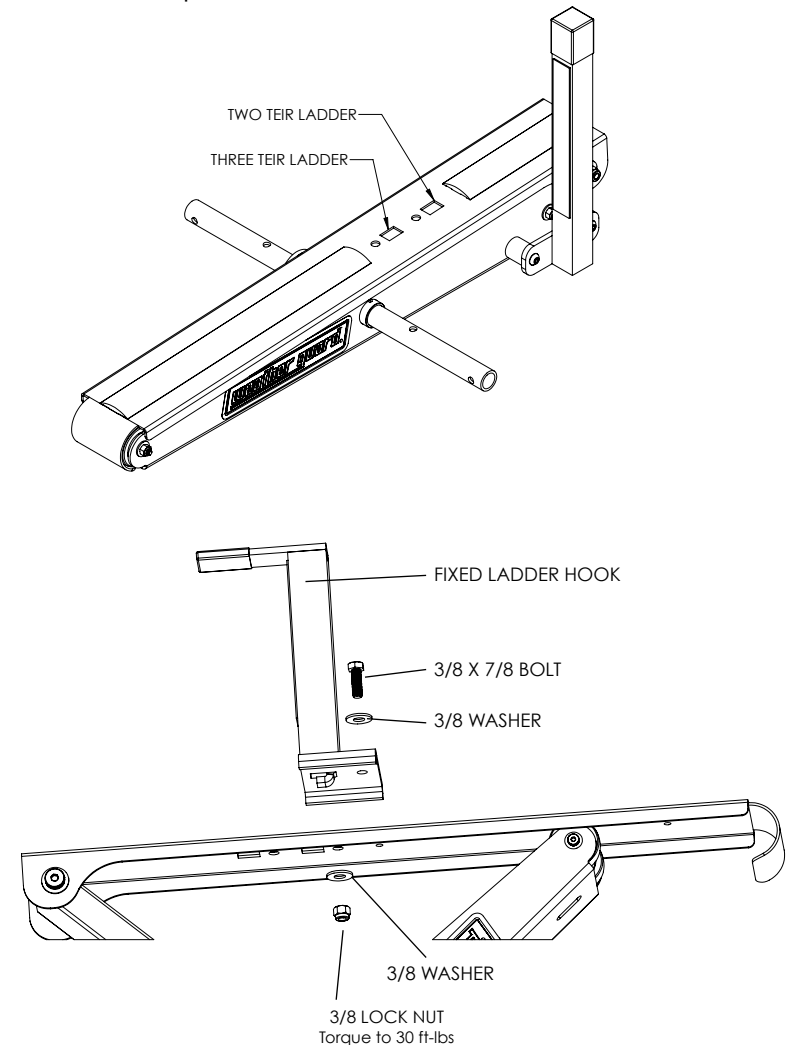

STEP 3 - MOUNT MOUNTING FEET TO CROSS MEMBER

• FOR 2265-3-01, PROCEED TO STEP 5

Only use one carriage bolt, washer, and nut per mounting foot.

Using 1-5/16x3/4" carriage bolt, 1-5/16" washer, and 1-5/16" nylon lock nut per mounting foot, install two mounting feet per cross member. Please refer to the table and diagram for mounting foot location and orientation.

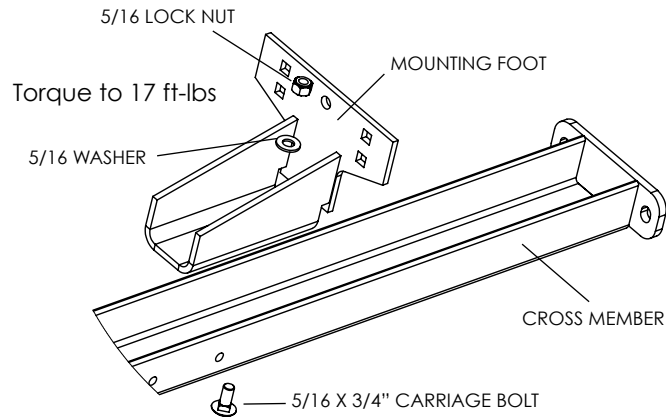

INSTALL MOUNTING FEET ACCORDING TO TABLE

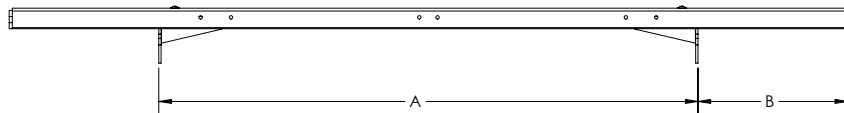

MOUNTING FOOT DISTANCE		
VEHICLE	DIM "A"	DIM "B"
FORD TRANSIT CONNECT (FRONT)	46-1/4"	6-3/8"
FORD TRANSIT CONNECT (REAR)	47-1/4"	5-7/8"
RAM PROMASTER CITY (FRONT)	42"	8-1/2"
RAM PROMASTER CITY (REAR)	41-3/8"	8-13/16"
CHEVY CITY EXPRESS	45-3/8"	6-13/16"
NISSAN NV200	45-3/8"	6-13/16"

STEP 4 - INSTALL CURVED MOUNTING BRACKETS

Using 2-5/16x3/4" carriage bolt, 2-5/16" washer, and 2-5/16" nylon lock nut per mounting foot install a curved mounting bracket to each mounting foot. Torque nuts to 17 ft-lbs.

If using an impact driver to torque nuts, it is recommended that the carriage bolt orientation be reversed to engage the square cut outs in the mounting foot.

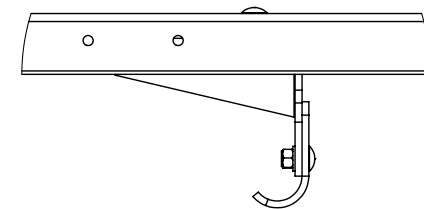
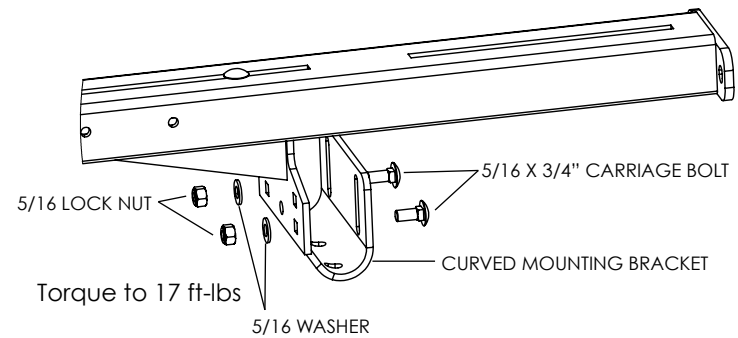

Most vehicle installations will benefit from having the lowest installed height with the mounting bracket lining up with the start of the curve on the curved mounting bracket. Due to vehicle roof curvatures some adjustment for final assembly height may be required after the crossmembers are installed on the roof.

STEP 5 - INSTALL DROP DOWN MECHANISMS TO CROSS MEMBERS

Installation will be easier if you can get more access between the rear cross member and van roof. Begin by loosening the 5/16-18 Lock Nuts holding the cross member to the mounting channels. Remove and retain hardware for re-assembly in Step 6.

Check that both sliding mechanisms are on the same cross member and both fixed mechanisms are on the same cross member.

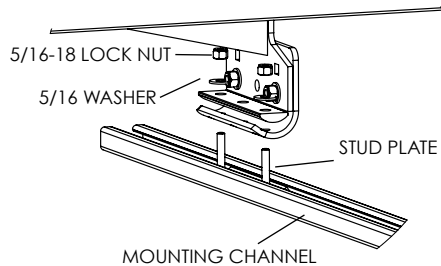

Using 2-5/16x3/4" carriage bolt, 2-5/16" washer and 2-5/16" nylon lock nut per drop down mechanism, install each drop down mechanism to the cross members. The end of the bottom bracket on the drop down mechanism should line up with the end of the cross member. Torque nuts to 17 ft-lbs.

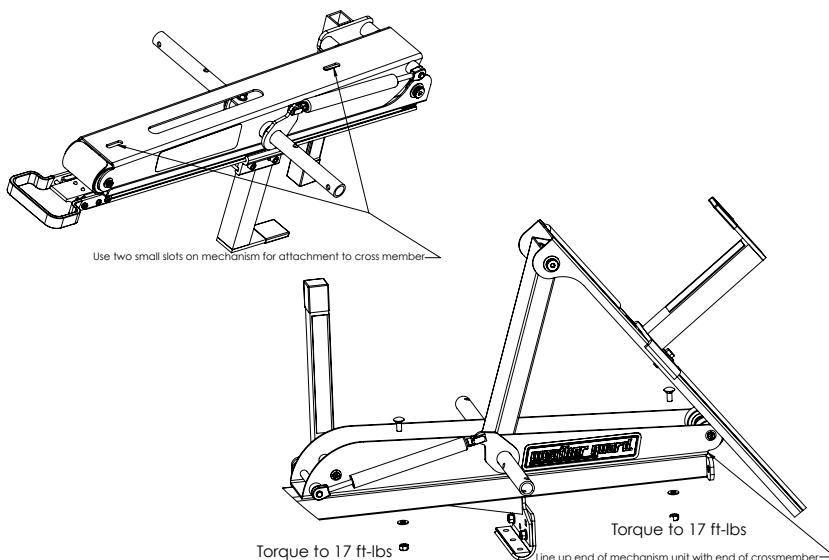

STEP 6 - INSTALL CENTER CONNECTING TUBE

• **FOR 2265-3-01, PROCEED TO STEP 7**

Rotate and position the connecting tube on the drive tube until all 4 mounting holes line up. Using 2-5/16x1-3/4" bolts, 4-5/16" washers, and 2-5/16" nuts, install the connecting tube. Torque 5/16 nuts to 17 ft-lbs.

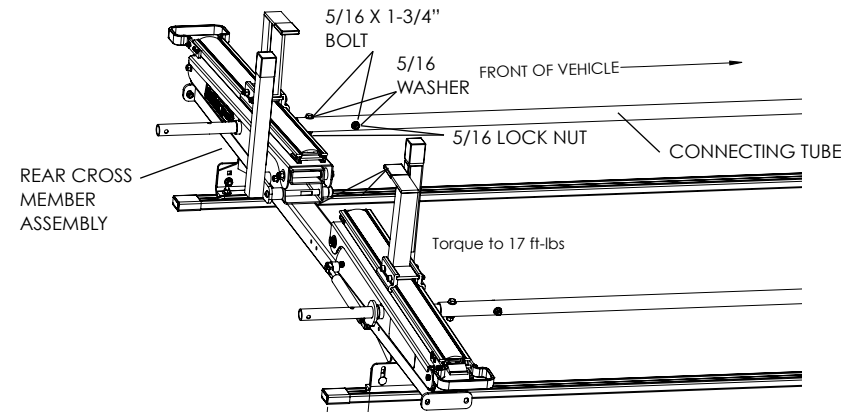

Using 2-5/16x1-3/4" bolts, 4-5/16" washers, and 2-5/16" nuts, install the connecting tube on the front drive tube. Rotate and position the center connecting tube until all 4 mounting holes line up and then drop cross member onto stud plates. Torque 5/16 nuts to 17 ft-lbs.

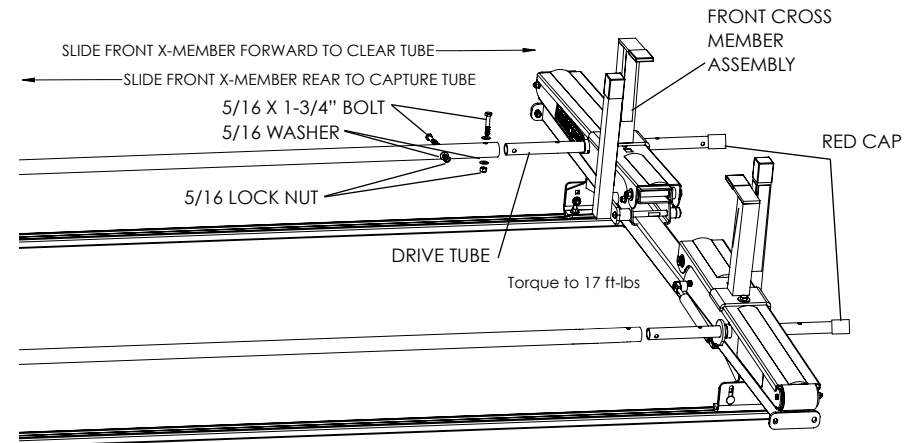



STEP 7 - MOUNT CENTER CROSS MEMBERS TO VEHICLE

Slide two stud plates per mounting channel into mounting channel if not already done. If installing a dual setup with 3 cross members, 3 stud plates will be used per mounting channel. Using 2-5/16" washers, 5/16-18" nylon lock nuts, and 1 mounting foot bolt plate per mounting foot, install the rear cross member on the mounting channel. The cross member that has the slide down mechanism should be installed in the rear position.

The EZ GLIDE2 can be installed on either the street side or curb side of the van. Decide which side to install the drop-down before mounting it to the vehicle.

Locate the cross member approximately 1-3" from the end of the mounting channel and hand tighten each 5/16-18" nut. The 5/16-18" nuts will need to be kept loose until step 7 is complete.

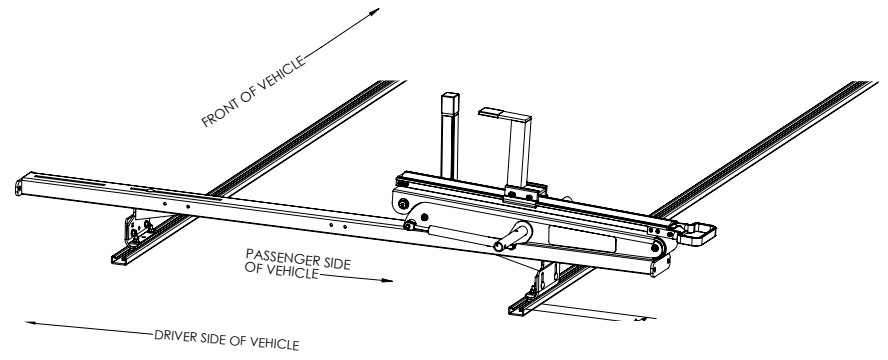
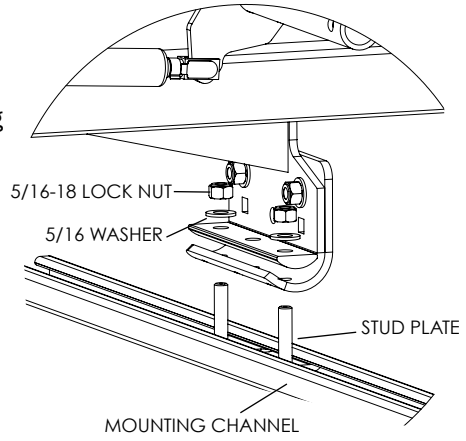

STEP 8 - INSTALL CENTER CONNECTING TUBE

Rotate and position the connecting tube on the drive tube until all 4 mounting holes line up. Using 2-5/16x1-3/4" bolts, 4-5/16" washers, and 2-5/16" nuts, install the connecting tube. Torque 5/16 nuts to 17 ft-lbs. Using 2-5/16x1-3/4" bolts, 4-5/16" washers, and 2-5/16" nuts, install the connecting tube on the front drive tube. Rotate and position the center connecting tube until all 4 mounting holes line up and then drop cross member onto stud plates. Torque 5/16 nuts to 17 ft-lbs.

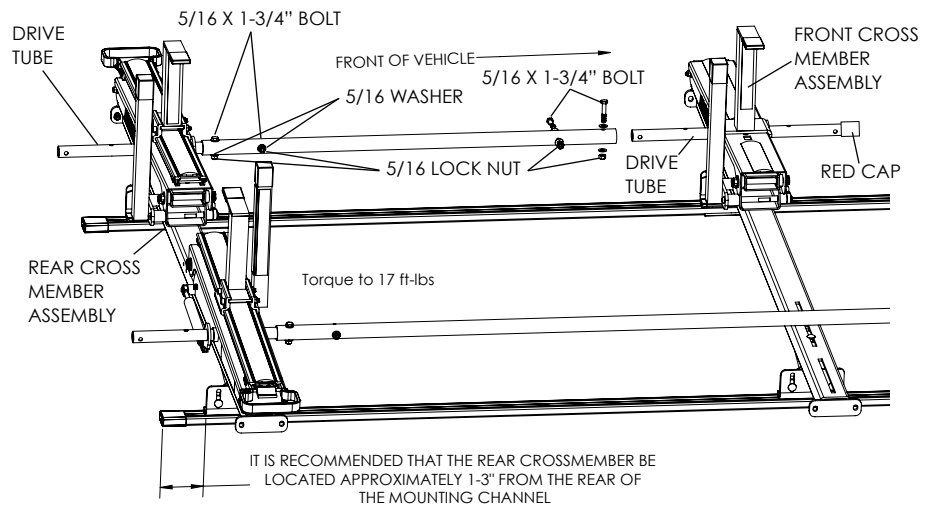

STEP 9 - INSTALL REAR DRIVE TUBE

Using 2-5/16x1-3/4" bolts, 4-5/16" washers, and 2-5/16" nylon lock nuts, install the drive tube to the rear drop down mechanism. Rotate and position tube until all 4 mounting holes line up and torque nuts to 17 ft-lbs.

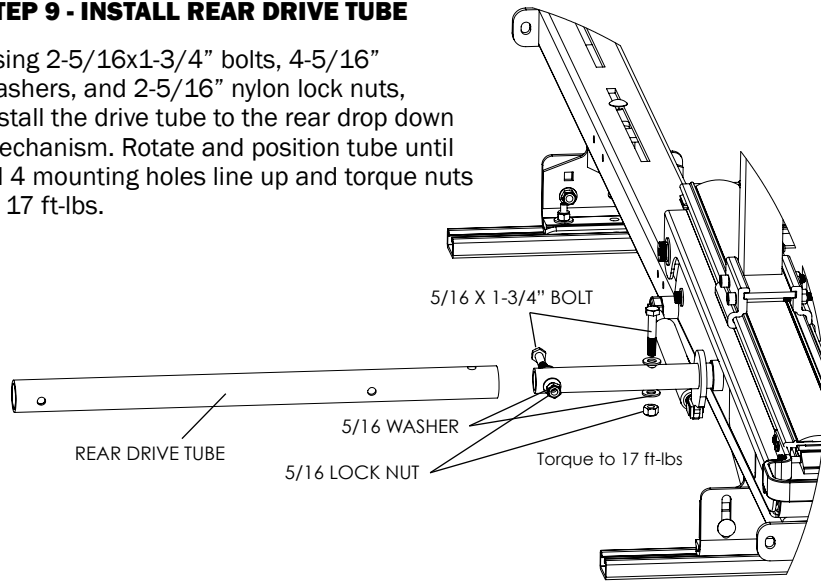

STEP 10 - INSTALL REAR COUPLING

Install the rear coupling to the drive tube using the coupling bushing and clevis pin. The coupling should be installed with the red cap on top and the open end pointing AWAY from the center of the van.

The rear coupling may fit too tightly when first assembled. If it sticks, rotate it a couple of times until it moves freely.

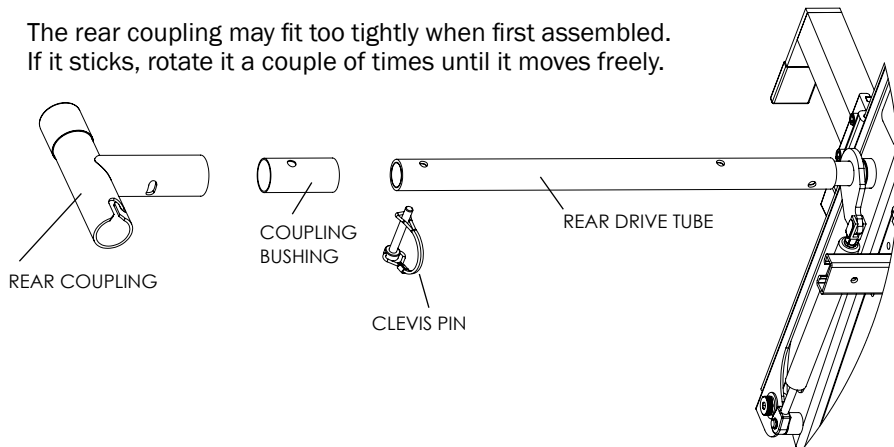

STEP 11 - POSITION AND SECURE LADDER RACK ASSEMBLY

Insert the handle into the rear coupler and ensure there is sufficient clearance between the back of the vehicle and the handle for full rotation. If more or less clearance is desired slide the rack forward or backwards in the mounting channels. Once the desired position is found, torque all 5/16-18" nuts to 17 ft-lbs to lock the position of the rack.

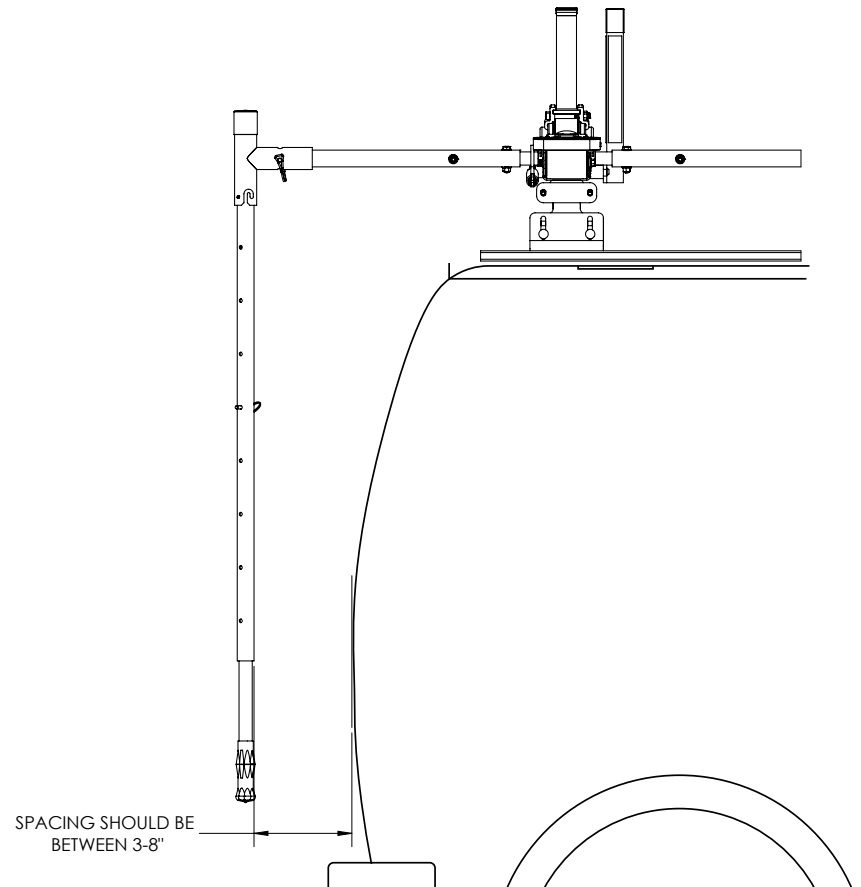

2265-3-01 & 2267-3-01 EZGLIDE2™ SERVICE PARTS

PART NO	DESCRIPTION	FITS MODEL NUMBER
70512	REPLACEMENT 70" CONNECTING TUBE FOR EZGLIDE2™ DROP-DOWN VAN RACK	2261-3-01, 2265-3-01
70513	REPLACEMENT 36" CONNECTING TUBE FOR EZGLIDE2™ DROP-DOWN VAN RACK	2267-3-01, 2265-3-01, 2267-3-01
70514	REPLACEMENT LADDER STOP KIT FOR EZGLIDE2™ DROP-DOWN VAN RACK	ALL MODELS
70515	REPLACEMENT LADDER HOOK KIT FOR EZGLIDE2™ FIXED DROP-DOWN MECHANISM	ALL MODELS
70517	REPLACEMENT BOLT KIT FOR MOUNTING CHANNEL KIT, 85 IN	2085-0-01
70520	REPLACEMENT RED PLASTIC CAP KIT FOR EZGLIDE2™ DROP-DOWN VAN RACK	ALL MODELS
70521	REPLACEMENT REAR HANDLE KIT FOR EZGLIDE2™ DROP-DOWN VAN RACK	ALL MODELS
70522	REPLACEMENT RUB STRIP KIT FOR EZGLIDE2™ FIXED DROP-DOWN MECHANISM	ALL MODELS
70524	REPLACEMENT DAMPER FOR EZGLIDE2™ DROP-DOWN VAN RACK	ALL MODELS
70528	REPLACEMENT BOLT KIT FOR MODEL 2271-3-01 EZGLIDE2™ DROP-DOWN VAN RACK	2271-3-01, 2261-3-01
70529	REPLACEMENT BOLT KIT FOR MODEL 2275-3-01 EZGLIDE2™ DROP-DOWN VAN RACK	2275-3-01, 2265-3-01
70530	REPLACEMENT BOLT KIT FOR MODEL 2277-3-01 EZGLIDE2™ DROP-DOWN VAN RACK	2277-3-01, 2267-3-01
70532	REPLACEMENT EZGLIDE2™ FIXED DROP-DOWN MECHANISM	ALL MODELS
70533	REPLACEMENT BUSHING KIT FOR EZGLIDE2™ DROP-DOWN VAN RACK	ALL MODELS