

# ASSEMBLY AND INSTALLATION INSTRUCTIONS

## All Purpose Rack - Models 205 • 215 • 216 • 2055 • 2056

**Approximate Assembly and Installation time:**  
 205: 36 min. per unit (.6 hrs.)  
 215 & 216: 48 min. per unit (.8 hrs.)  
 2055 & 2056: 18 min. per unit (.3 hrs.)  
 Depending on van equipment installation experience

The distinctive, trademarked **RED TIPS** are your assurance of **WEATHER GUARD®** Equipment quality.

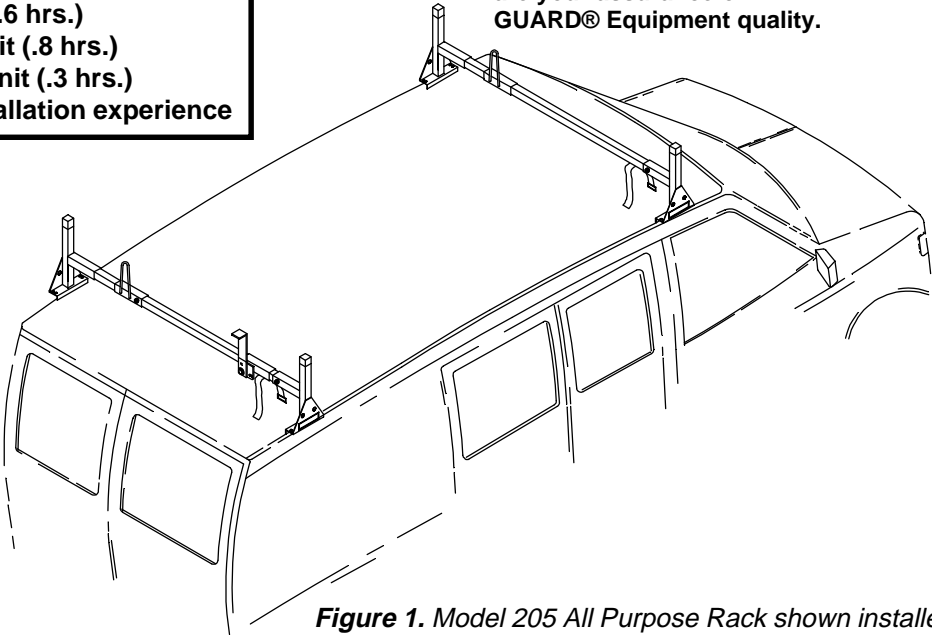

*Figure 1. Model 205 All Purpose Rack shown installed*

### IMPORTANT BEFORE YOU BEGIN

Read these instructions and warnings completely before installation.

**NOTE:** We have found varying tolerances between the top of the doors and the rain gutters on the 1992 to present full-size vans. Before placing van rack on vehicle, check the door clearance with the bottom clamp, by holding it to the underside of the rain gutter and slowly opening the door. If the door hits, you will have to move the clamp to where more clearance is available. Some cases may require moving the clamps rearward of the driver and passenger side doors.

**⚠ WARNING**

This product is only intended for, and only safe for, transporting ladders, lumber, pipe and other similar materials. It is the responsibility of the user to secure these materials to the rack before transporting. Any modifications made to this product, or use of this product for any other purpose than its intended use, could create a hazardous condition that can cause serious personal injury or property damage.

**⚠ CAUTION**

Load should be approximately centered front to rear on all vehicles. Failure to do this will cause damage to the vehicle roof.

### BOLT KITS

The following bolt kits are provided with each model. Check the bolt kit to be sure the following parts are included:

Model	205	215 216	2055 2056	Description
Bolt Kit	32-0146	32-0147	32-0148	
Quan.	8	12	4	1/4-20 x 1-1/2" Carriage Bolt
	8	12	4	1/4-20 Nylon Lock Nut
	8	12	4	1/4" Flat Washer
	7	10	3	3/8-16 x 3/4" Thread Cutting Bolt
	8	12	4	1/4-20 x 1" Carriage Bolt

### TOOLS REQUIRED

- 7/16" Open or Box End Wrench
- 9/16" Open or Box End Wrench



# PARTS LIST

205	215	216*	2055	2056*	Description
4	6	4	2	0	Stand (p/n 23-0198)
0	0	2	0	2	Center Stand (Ford) (p/n 23-0199)
1	2	2	1	1	Crossmember (p/n 20-0188)
4	6	6	2	2	Universal Clamp (p/n 21-0826)
2	3	3	1	1	Tie Down Loops (p/n 23-0109)
4	6	6	2	2	Mounting Cushion (p/n 21-0629)
1	1	1	1	1	Sealant (p/n 21-9121)
4	6	6	2	2	Spacer, Clamp (p/n 21-0827)
1	1	1	0	0	Ladder Stop Assembly
2	2	2	0	0	Ladder Straps
1	1	1	0	0	Front Crossmember (p/n 23-0394)

**\*NOTE:** Models 216 and 2056 are used exclusively on Ford and Chevy GMT600/GMC Savana vans due to the upward bow in the center of the gutter. The front and rear Stands have 7" long sockets. The third (center) Stand can be identified by the 5" socket that is 5/8" lower (*Stand B as shown in Figure 3.*) for the Ford and GM.

## Step 1. Rack Assembly

The Ladder Stop Assembly will face rearward on the rear Crossmember/Stand Assembly. If desired, it may be assembled on the driver side. Fasten the Crossmembers in the Stands.

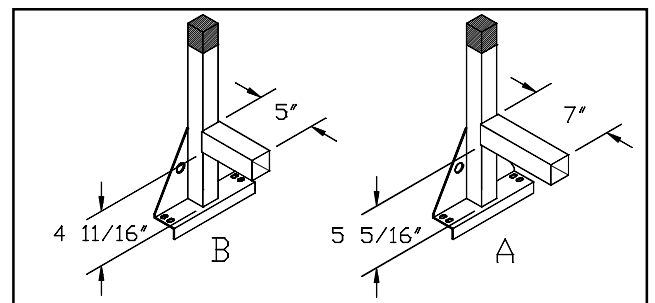

Figure 3. Center Stand Identification

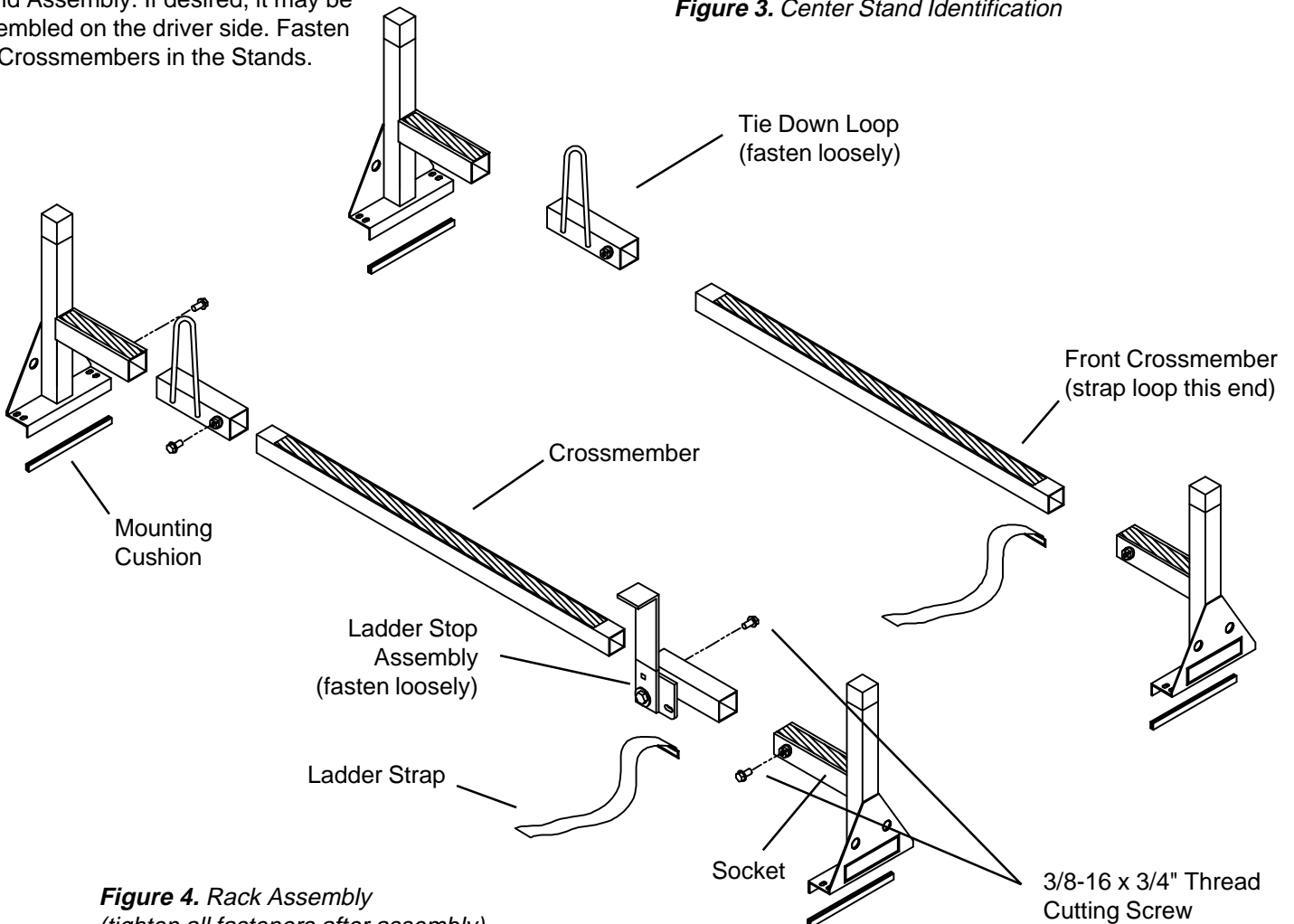
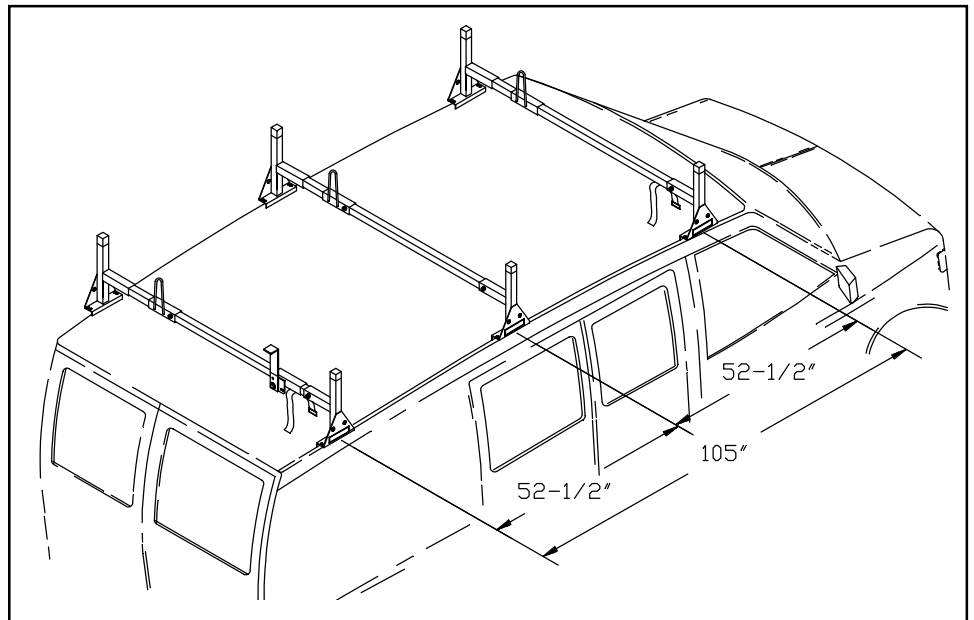

Figure 4. Rack Assembly  
(tighten all fasteners after assembly)

## Step 2. Rack placement.

The preferred rack placement will locate the rear of the front stands even with the rear edge of the front doors. When installing a three crossmember van rack, use the dimensions shown in *Figure 5*. All measurements are from center to center of the stands. The van rack placement on the roof can vary somewhat, and the dimensions (shown in *Figure 5*) may vary due to variations in the gutter bow.

**NOTE:** Gutter widths vary, some vans will require the Crossmember to be cut. All Crossmembers for Chevy GMT 600/GMC Savana vans will have to be cut to length, as well as the rear Crossmember on a Ford van. Insert each crossmember end into a Stand. Carefully place each Crossmember/Stand in position (see *Figure 5*), laying the Crossmember on/across the roof. On the opposite side of the van from the Stands, place a Stand in the gutter so the Stand socket is alongside the Crossmember. Raise the Crossmember end off the roof so that it and the Stand socket are horizontal. Mark the Crossmember 1" short of the Stand upright tube. Remove the Stand and Stand Crossmember from the van. Cut the Crossmember end off at the mark.



**Figure 5.** Stand Placement Dimensions

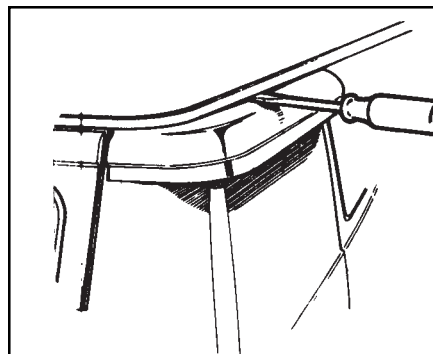

**NOTE:** Some vans have a guard over the sliding door track, spot welded in place. If the Clamp will not fit between the spotwelds, see *Figure 6*. If the Clamp will not fit between the spotwelds, place a flat screwdriver at the restricting weld and strike it with a hammer to break the weld. This will give the guard flexibility to insert the clamp under the rain gutter.

**Figure 6.** Breaking Weld

## Step 3. Fasten Clamps.

Fasten the clamps to the Stands according to your application. See below for GM application and Page 4 for all other applications

**GM application:** The Stand must contact the roof gutter, the Clamp must engage under the gutter, and the bolt holes must align as shown in *Figure 7*. **DO NOT** install as shown in *Figure 8*. Due to excess body caulk in some gutters on GM vans, the Carriage Bolts will be unable to align to the holes in the Stands. In those cases, a portion of the caulk might have to be cut out of the gutter and then re-caulked after the rack is installed.

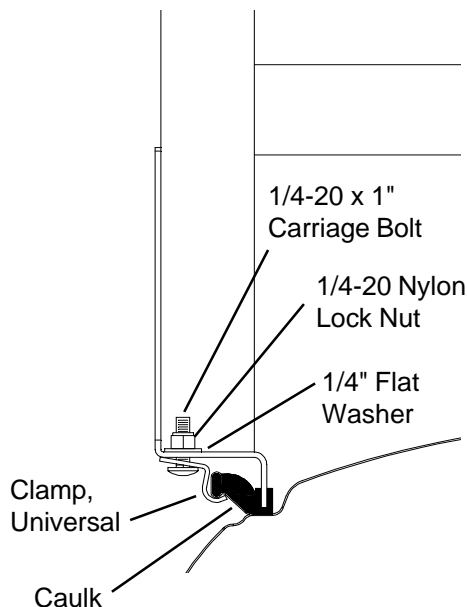

**Figure 7.** Clamping to a GM van



**Figure 8.** Example of unacceptable mounting. Not enough engagement of clamp and Stand does not contact bottom of gutter.

**All other applications:** The Stand must contact the vans gutter and installed as shown in *Figure 9*. A Spacer will need to be installed between the Clamp and the Stand.

At the end of the first week of use, check all of the fasteners for proper tightness and then check every three months thereafter.

#### Step 4. Sealant

Seal all seams and crevices, such as socket tube ends.

**WARRANTY WILL BE VOID IF SEALANT IS NOT APPLIED TO ALL SEAMS AND CREVICES**

#### Step 5. Tie Down Loop and Ladder Stop.

Secure the Tie Down Loop to the Crossmember after determining where you want it to hold your ladder. With a Ladder on the rack, locate the Ladder Stop inside of the ladder and then secure. Insert a strap through the loop on the Ladder Stop and on the front Crossmember. **Refer to the warning decal on the Ladder Stop.**

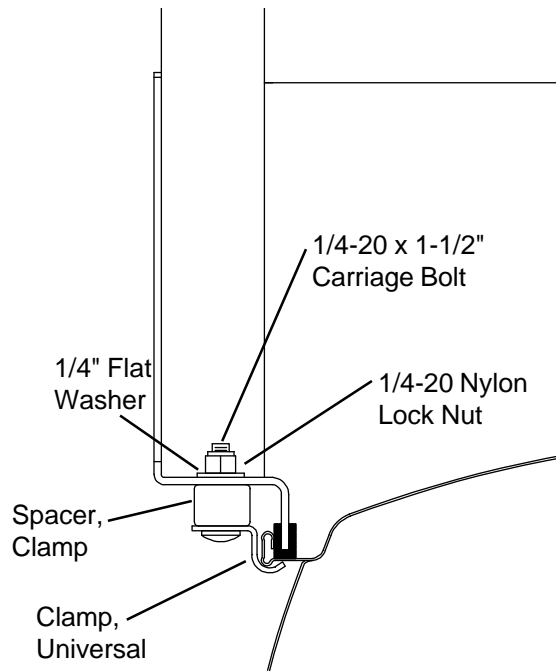

*Figure 9. Clamping to a Ford or Dodge*

### **! WARNING**

Ladders must be secured per ANSI standard A142.2-1990 paragraph 8.4.4. Ladder damage will occur from road shock and vehicle vibration if the ladder is not properly secured to the ladder rack. Bouncing and side to side motion of a improperly secured ladder will cause wear and weaken the ladder. Using a damaged ladder could lead to a structural collapse and could result in a serious injury or death.

### **-NOTICE-**

**Any modification or unintended use of this product shall immediately void all manufacturers warranties. Manufacturer disclaims all liability for injuries to persons or property resulting from any modification to, or unintended use of this product.**