

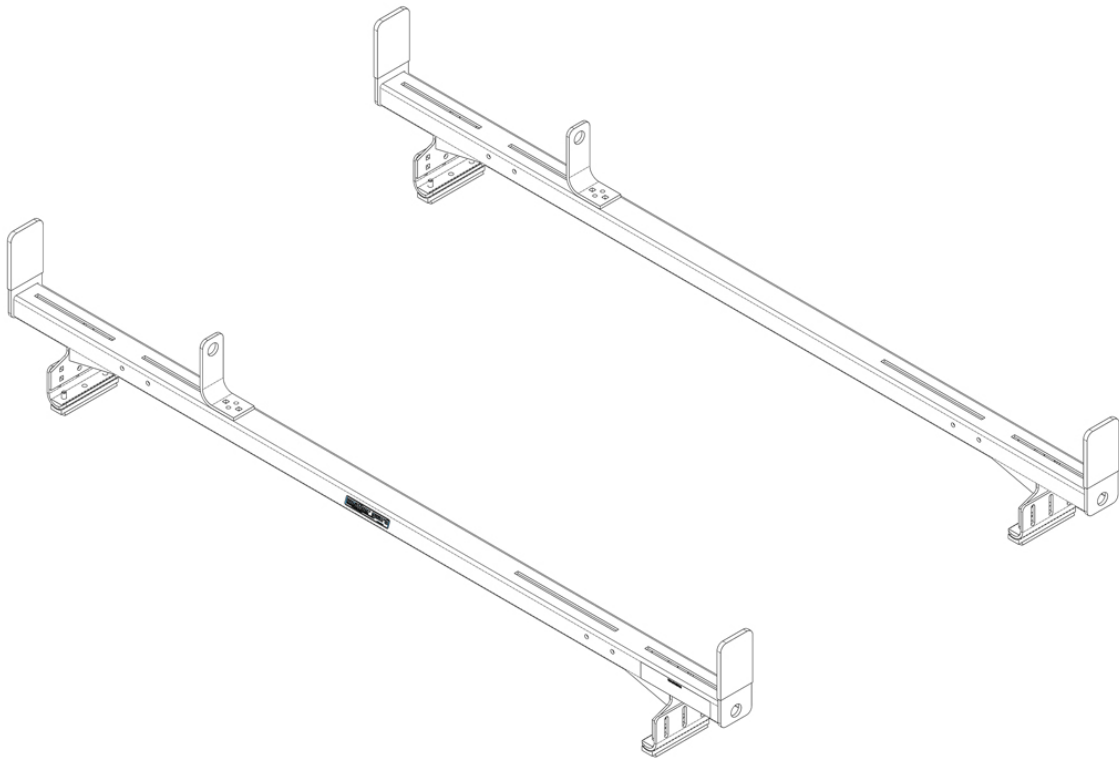

**VAN SOLUTIONS**  
FOR THE WAY YOU WORK™

**ASSEMBLY AND INSTALLATION INSTRUCTIONS FOR  
FULL SIZE ALL PURPOSE VAN RACK &  
ACCESSORY CROSS MEMBER**



**MODELS 209-3-03 AND 2097-3-03**

**ATTENTION: PLEASE READ AND UNDERSTAND ALL INSTRUCTIONS AND WARNINGS BEFORE ASSEMBLING, INSTALLING OR USING THIS PRODUCT.**

**! BEFORE YOU BEGIN**

- WEATHER GUARD® ladder racks are designed to work with OEM side gutters or with WEATHER GUARD® Mounting Channel kits to provide the best support for your ladders and to take advantage of OEM provided roof mounting points. If you have not already installed the mounting channel kit to the van roof, install it now before proceeding.
- We recommend that you use mounting channels to mount the ladder rack on to the roof due to the mounting channels being able to distribute the load more evenly. We have provided spacers that can be used to mount directly to the roof, but please consult the vehicle manufacturer to determine the load capacity allotted for the roof.
- Review vehicle manufacturer’s roof mount recommendation.
- Perform the installation on a leveled surface.
- Always wear protective eyewear to keep debris out of your eyes when installing WEATHER GUARD® Van Products.
- All of the nylon lock nuts are torqued to 17 ft-lb when ready.

**MOUNTING LONG LADDERS ON VANS**

Ladders transported on a vehicle should be properly supported and the overhang of the ladders beyond supporting points should be limited. Transporting a ladder with excessive overhang can result in reduced ladder life. Inspect your ladder before each use. Follow ANSI 14.2-2007 for direction on securing ladders to ladder racks.

Follow manufacturer’s guidelines for maximum allowable roof load. Do not overload the vehicle’s roof.

**HARDWARE KIT**

DESCRIPTION	209-3-03	2097-3-03
5/16-18 x 1-3/4" SS Carriage Bolt	4	2
5/16-18 x 1-1/4" SS Carriage Bolt	8	
5/16-18 x 7/8" SS Carriage Bolt	16	8
5/16-18 SS Nylon Lock Nut	36	18
5/16" SS Washer	36	18
1/4-20 x 1/2" SS Taptite Screw	0	0
1/2" OD 1/8" SS Spacers	8	4
M8-1.25 x 40mm SS Cap Screw	4	2

**TOOLS REQUIRED**

- Electric drill-driver
- 1/2" ratchet wrench
- 1/2" and 3/8" socket
- Needle nose pliers
- Open end wrenches 7/16" and 9/16"

# 209-3-03 & 2097-3-03 FULL SIZE ALL PURPOSE VAN RACK & ACCESSORY CROSS MEMBER

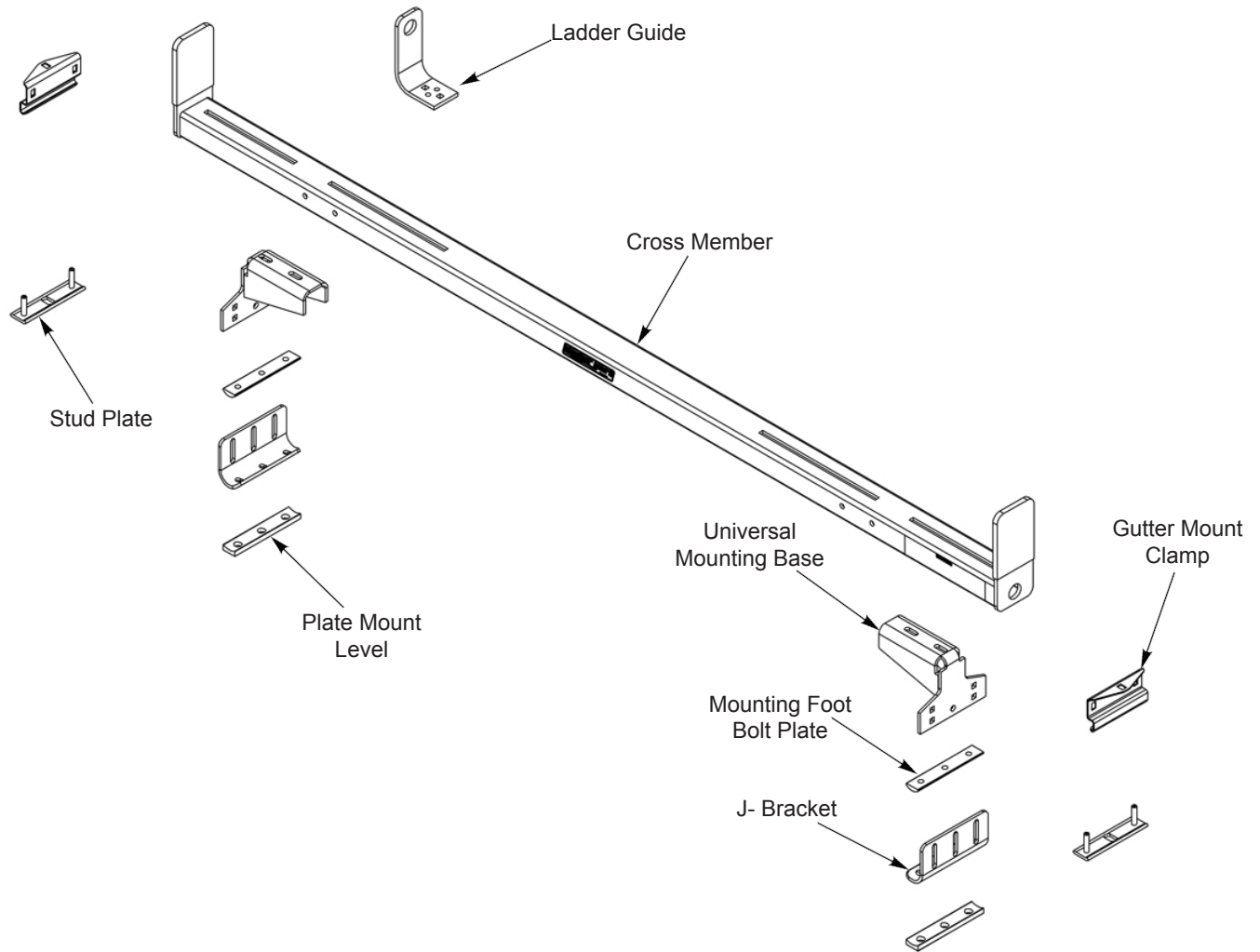

## 209-3-03

DESCRIPTION	QTY.
Cross Member	2
Ladder Guide	2
Universal Mounting Base	4
Mounting Level Plate	4
Mounting Foot Bolt Plate	4
J-Bracket	4
Stud Plate	4
Gutter Mount Clamp	4
Velcro Strap	2

## 2097-3-03

DESCRIPTION	QTY.
Cross Member	1
Ladder Guide	1
Universal Mounting Base	2
Mounting Level Plate	2
Mounting Foot Bolt Plate	2
J-Bracket	2
Stud Plate	2
Gutter Mount Clamp	2
Velcro Strap	0

## INSTALLATION INSTRUCTIONS

### STEP 1A. LOOSELY INSTALL J-BRACKET TO UNIVERSAL MOUNTING BASE

(Ford Transit, RAM Promaster, Nissan NV, and MB Sprinter)

Using (2) 7/8" tall carriage bolts, (2) washers, and (2) nylon lock nuts.

**NOTE:** J-bracket can be installed in multiple configurations to result in the best fitment to your vehicle. Bolts can be installed from both direction. Most vehicle installations will benefit from having the lowest installed height with the mounting bracket lining up with the start of the curve on the J-bracket. Due to vehicle roof curvatures, some adjustment for final assembly height may be required after the cross members are installed on the roof.

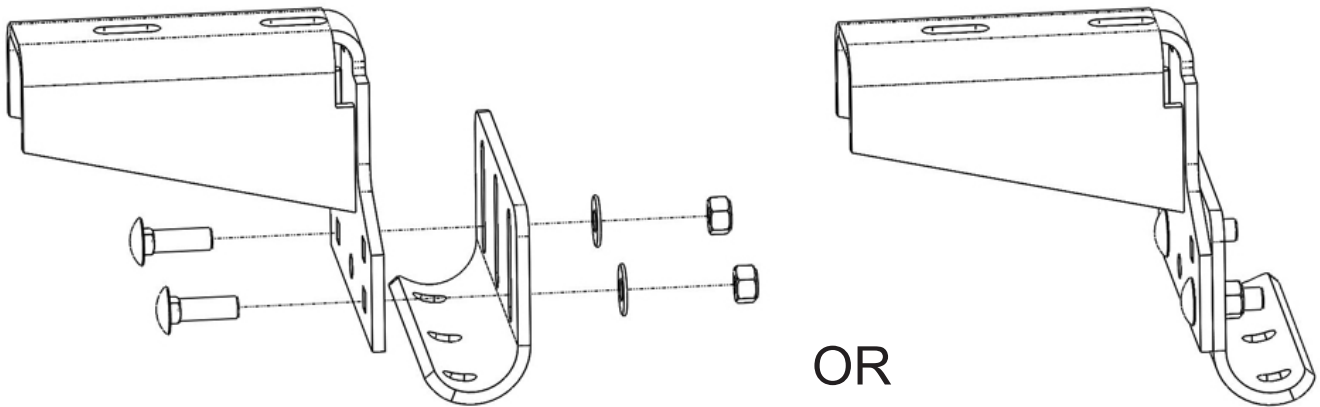

### STEP 1B. LOOSELY ASSEMBLE GUTTER MOUNT CLAMP AND J-BRACKET TO UNIVERSAL MOUNTING BASE

(GMC Savana / Chevy Express, and Ford E-Series)

Using (2) 1-1/4" tall carriage bolts, (1) 1-3/4" tall carriage bolt, (3) washers, and (3) nylon lock nuts.

**NOTE:** J-bracket must be installed as shown but it can be mounted on either top or bottom set of square holes on the universal mounting base (bottom mounting position shown below).

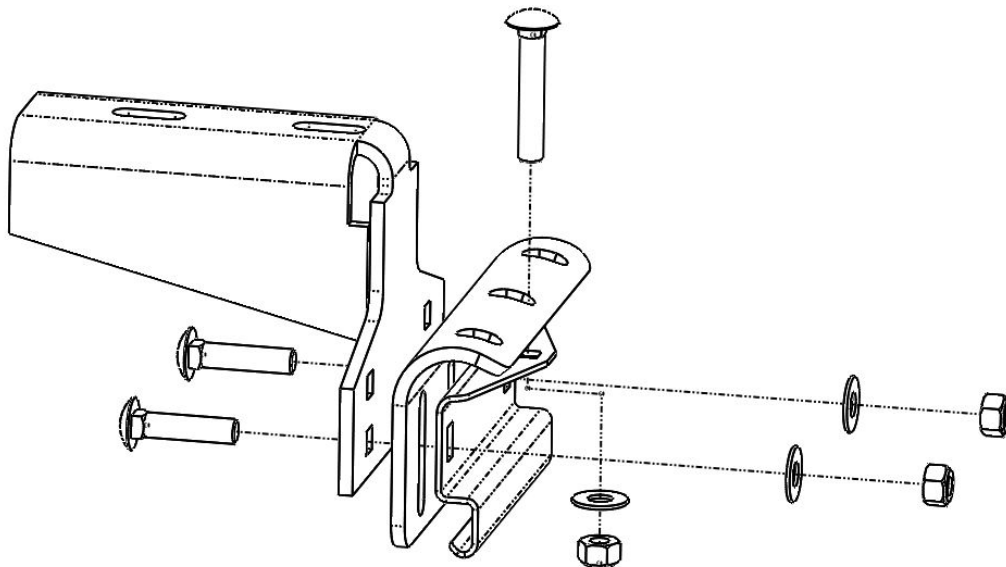

## INSTALLATION INSTRUCTIONS

### STEP 2. MOUNT MOUNTING FEET TO CROSS MEMBERS

Use one 7/8" carriage bolt, washer and nylon lock nut per mounting foot, Install feet to cross member, Refer to table and diagram below for mounting foot location and orientation.

**NOTE:** Mounting feet can be installed in the other direction if need be (Toes in vs. Toes out).

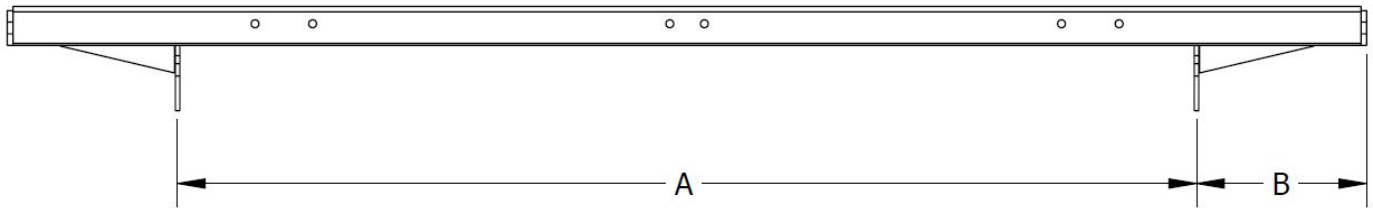

### MOUNTING FOOT DISTANCE

VEHICLE	A		B		MOUNTING METHOD
Ford Transit	55-1/2"		6-3/8"		WG Mounting Channel
RAM Promaster	59-5/8"		5-7/8"		WG Mounting Channel
Nissan NV	59-3/8"		8-1/2"		WG Mounting Channel
MB Sprinter *	53-1/4"		8-13/16"		WG/OEM Mounting Channel
GMC Savana / Chevy Express *	F: 58-7/8"	F: 57-7/8"	F: 5-1/16"	F: 5-5/8"	Gutter Mount
Ford E-Series *	F: 62-7/8"	F: 60-3/4"	F: 3-1/16"	F: 4-1/8"	Gutter Mount

**\* Due to the curvature of the gutter on each van, the dimensions given are a reference point. Please make appropriate adjustments to ensure a tight and secure fit, with the cross member centered on the width of the van.**

## INSTALLATION INSTRUCTIONS

### STEP 3. INSTALL LADDER GUIDES

Place the ladder on the rack to adjust the ladder guide position to fit your ladder.  
Using (2) 7/8" tall carriage bolts, (2) washers, and (2) nylon lock nuts, fasten the ladder guide.

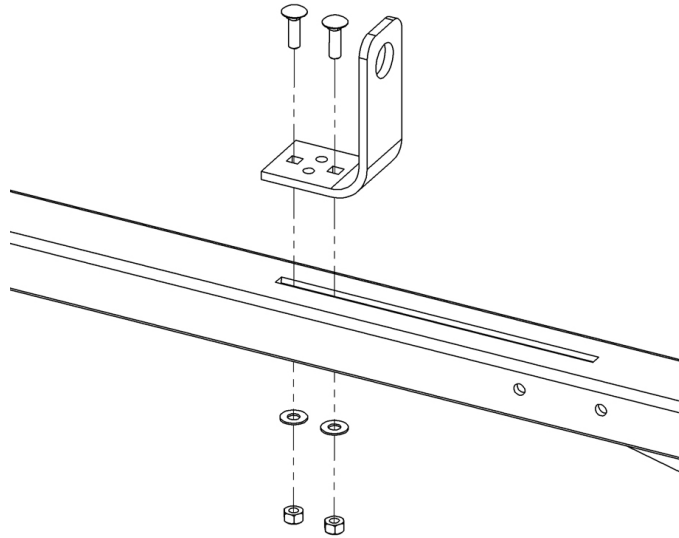

### STEP 4A. MOUNT CROSS MEMBERS TO VEHICLE - (Ford Transit, Nissan NV, and MB Sprinter)

Slide two stud plates per mounting channel if not already done. Lift the assembled ladder rack and place it on the stud plates on all four corners. Use (2) washers, (2) nylon lock nuts, and a bolt plate to fasten each mounting foot.

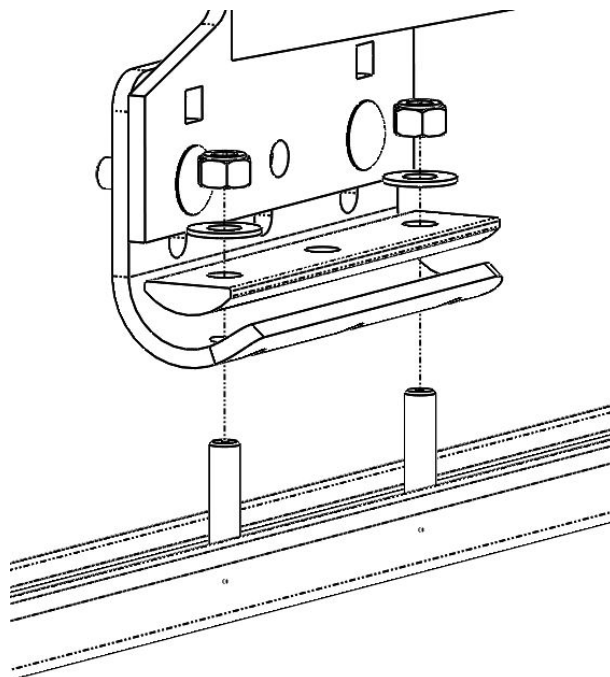

## INSTALLATION INSTRUCTIONS

### STEP 4B. MOUNT CROSS MEMBERS TO VEHICLE - (GMC Savana / Chevy Express, and Ford E-Series)

Make sure that the gutter is clamped between the gutter clamp and the inverted J-bracket.

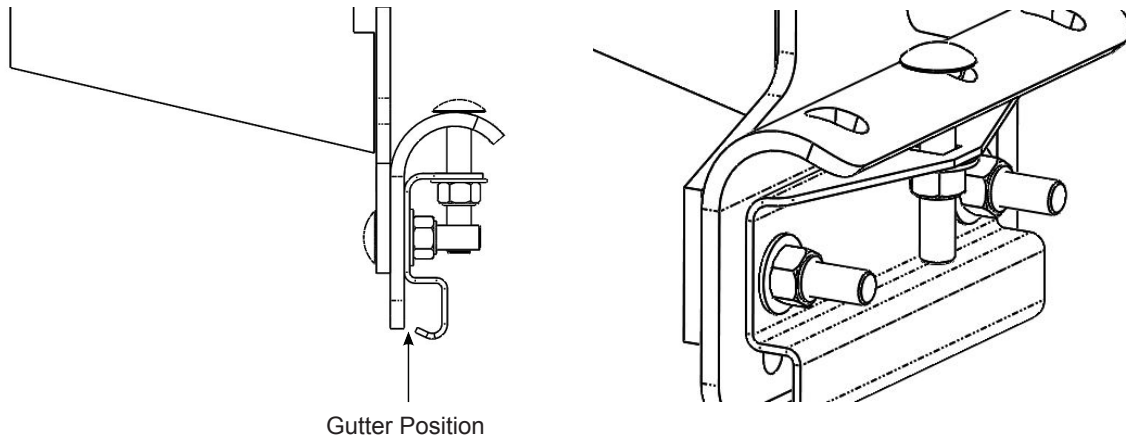

Position the cross member to desired position and tighten the two nuts to 17 ft-lb. Vertically constrain the inverted J-bracket and the gutter clamp using one 1-3/4" carriage bolt, washer, and a nut.

### STEP 4C. MOUNT CROSS MEMBERS TO VEHICLE - (RAM Promaster)

The 2113-0-01 or 2115-0-01 mounting channel kits are used on RAM Promaster vans. For 159" wheel-base and the 159" wheel-base extended versions as well as 136" wheel-base with the 2113-0-01 mounting channel kit, the rear cross member is mounted directly to the rear-most mounting point on the roof. The front cross member and the center cross member (if used), mount to the channels as shown in step 10A.

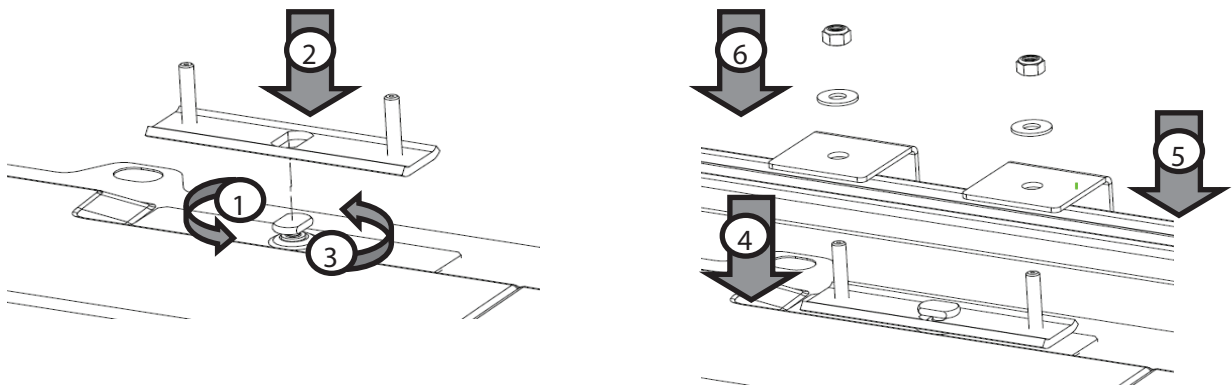

1. Rotate roof cleat 90°
2. Place stud plate over cleat.
3. Rotate roof cleat back to the original position.
4. Place channel over studs.
5. Place brackets over the channel.
6. Retain with 5/16-18 nut and washer.

### STEP 5. TIGHTEN DOWN ALL HARDWARE

Make sure everything is aligned and installed properly and torqued to 17 ft-lb.

## SERVICE PARTS

<b>PART NO.</b>	<b>DESCRIPTION</b>
7870	Ladder Guide
7877	Velcro Strap
2070-3-01	70" Cross Member & Mounting Feet
72214	Bolt Kit AP
72216	Bolt Kit 125
72217	Gutter Clamp Kit



 **WARNING**

This product can reduce the driver's ability to clearly see roadways, vehicular or pedestrian traffic and other objects through the rear and side windows of the vehicle, which can cause an accident. Extra precautions should be taken when driving a vehicle with this product. Make all adjustments necessary to ensure maximum visibility, including but not limited to, changing mirror and seating positions. State and local laws may prohibit obstruction of windows in a moving vehicle.

These instructions are to be followed using the parts and fasteners supplied for proper installation. Any modifications or improper installation of this product will create a hazardous condition that could result in death, serious personal injury and/or property damage.

 **CAUTION**

Prior to drilling, so as not to cut electric wires, fuel lines, brake lines, etc., check behind and underneath drilling and mounting locations. To keep debris out of your eyes when checking the underside of the vehicle, or when drilling, always wear protective eye wear. Failure to heed this warning will result in death or serious injury.

**– NOTICE –**

Any modification or unintended use of this product shall immediately void all manufacturers warranties. Manufacturer disclaims all liability for injuries to persons or property resulting from any modification to, or unintended use of this product.

