

# ASSEMBLY AND INSTALLATION INSTRUCTIONS

## Model 1285 Accessory Screen

(Fits Model 1280 Full Size Truck Rack)

### IMPORTANT BEFORE YOU BEGIN

Read these instructions and warnings completely before assembly and installation.

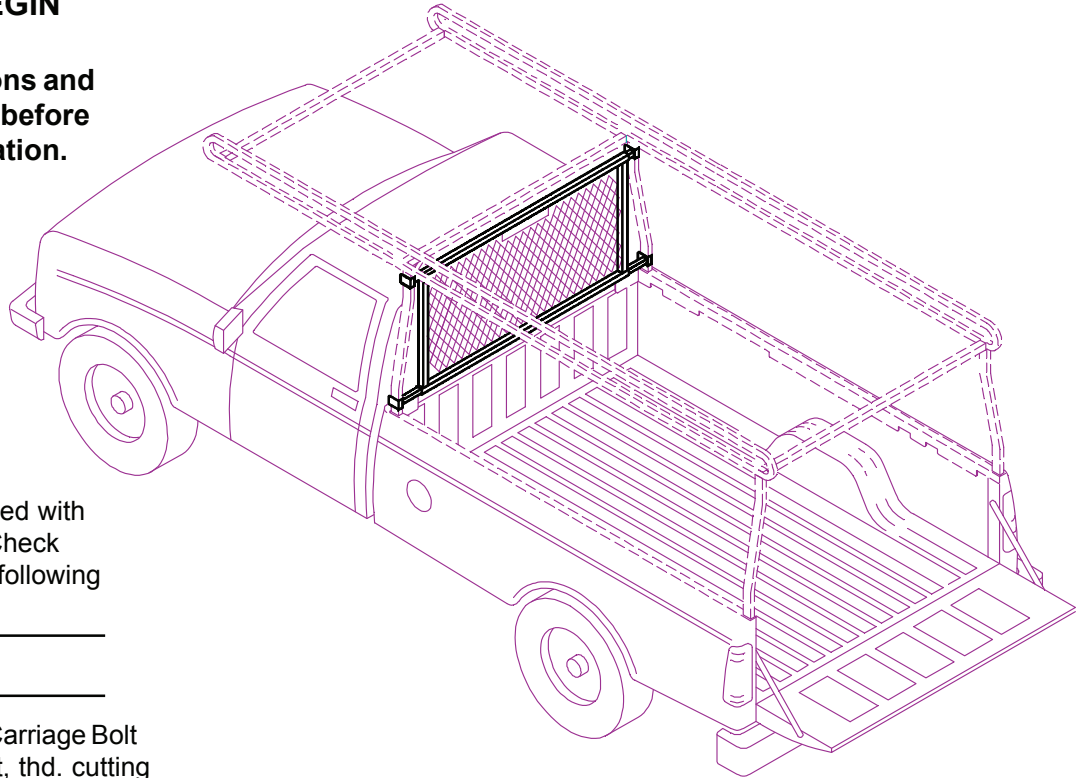

### BOLT KIT

Bolt Kit #32-0094 is provided with your Accessory Screen. Check this bolt kit to be sure the following parts are included:

Quan.	Description
-------	-------------

4	5/16-18 x 2-1/4 Carriage Bolt
4	3/8-16 x 3/4 Bolt, thd. cutting
4	5/16-18 Nylon Lock Nut
4	5/16 Flat Washer

### PARTS LIST

- 1- Screen Assembly
- 4- Screen Sockets
- Tube E-6000 Sealant

### TOOLS REQUIRED

- 1/2" & 9/16" Open or Box End Wrench

## ⚠ WARNING

This product can reduce the driver's ability to clearly see roadways, vehicular or pedestrian traffic and other objects through the rear and side windows of the vehicle, which can cause an accident. Extra precautions should be taken when driving a vehicle with this product. Make all adjustments necessary to ensure maximum visibility, including but not limited to, changing mirror and seating positions. State and local laws may prohibit obstruction of windows in a moving vehicle.

**weather guard**

### Step 1. Socket Assembly.

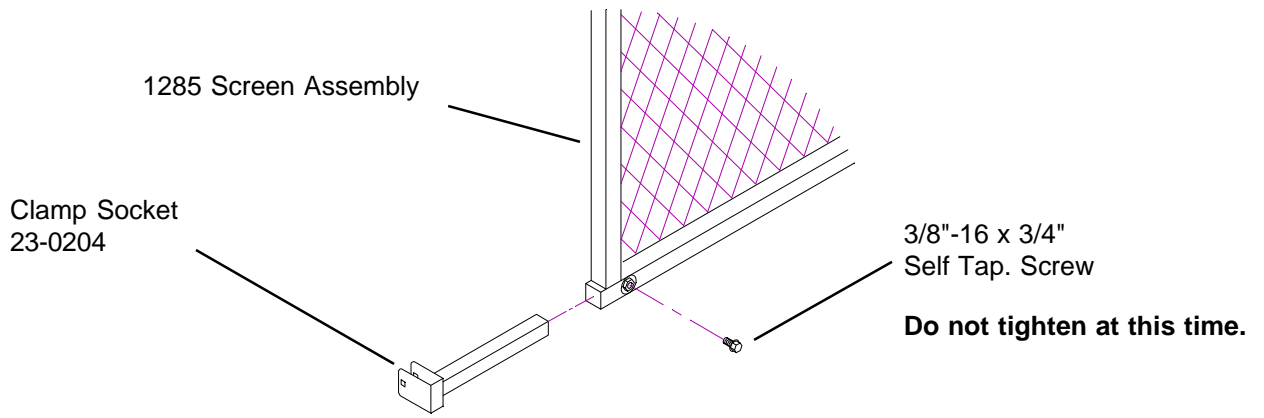

### Step 2. Frame to Rack Assembly.

Center screen between the ladder rack legs.

**NOTE: The cutout in the screen must be in alignment with the light mounted on the rear of cab.**

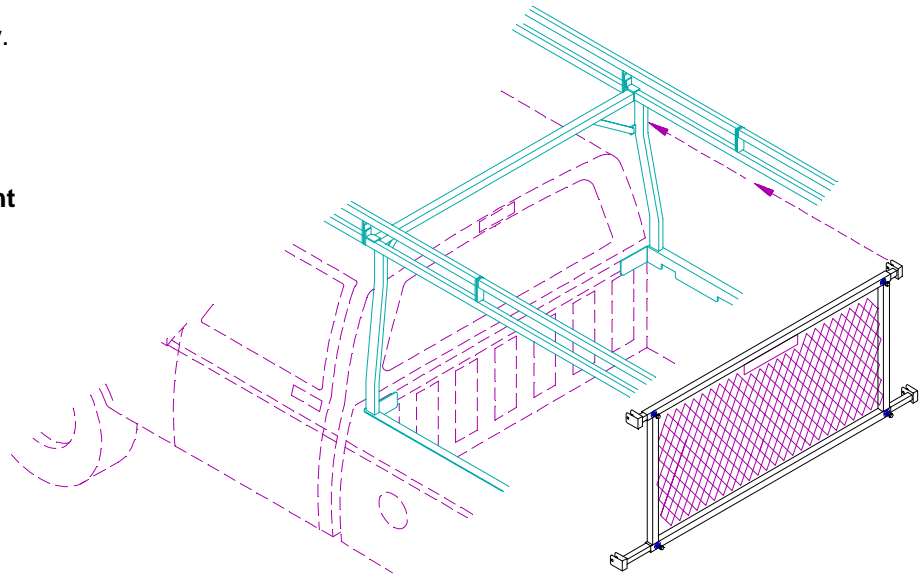

### Step 3. Clamping and Sealant

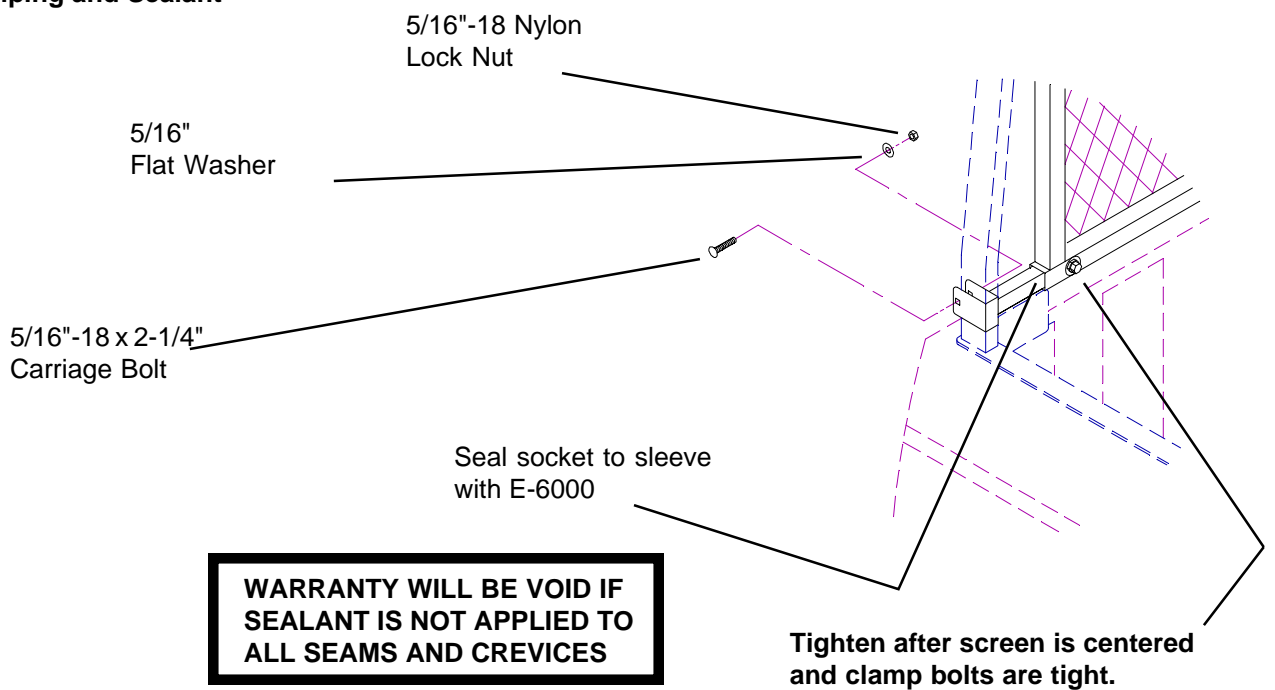

## **WEATHER GUARD® REFINISHING PROCEDURES**

All WEATHER GUARD® products are finished with a polyester powder coating, and it is important to follow these procedures to get proper adhesion. As Knaack LLC cannot control the finishing of the products, Knaack LLC's warranty on paint is not applicable on refinished products.

- 1.** Sand the surface to be painted with 180-200 grit sand paper to rough up the surface. This should be followed by wet sanding with a 400 grit wet or dry paper.
- 2.** Wipe down the sanded surface with ketone based thinner. This removes the dust and softens the powder coating for better paint adhesion.
- 3.** Wipe sanded area with a tack rag to remove loose dust and particles before painting.

**NOTE: Do not use a lacquer over the powdered coating.**