



TRUCK STORAGE SOLUTIONS
SECURING YOUR REPUTATION®

INSTALLATION MANUAL

PROTECT-A-RAIL® CAB PROTECTOR

ATTENTION: PLEASE READ AND UNDERSTAND ALL INSTRUCTIONS AND WARNINGS BEFORE ASSEMBLING, INSTALLING OR USING THIS PRODUCT.

MODELS 1904-X-02, 1905-X-02, 1906-X-02, 1907-X-02

Note: X represents the color code for your model: 0 = Clear | 3 = White | 5 = Black | 52 = Matte Black

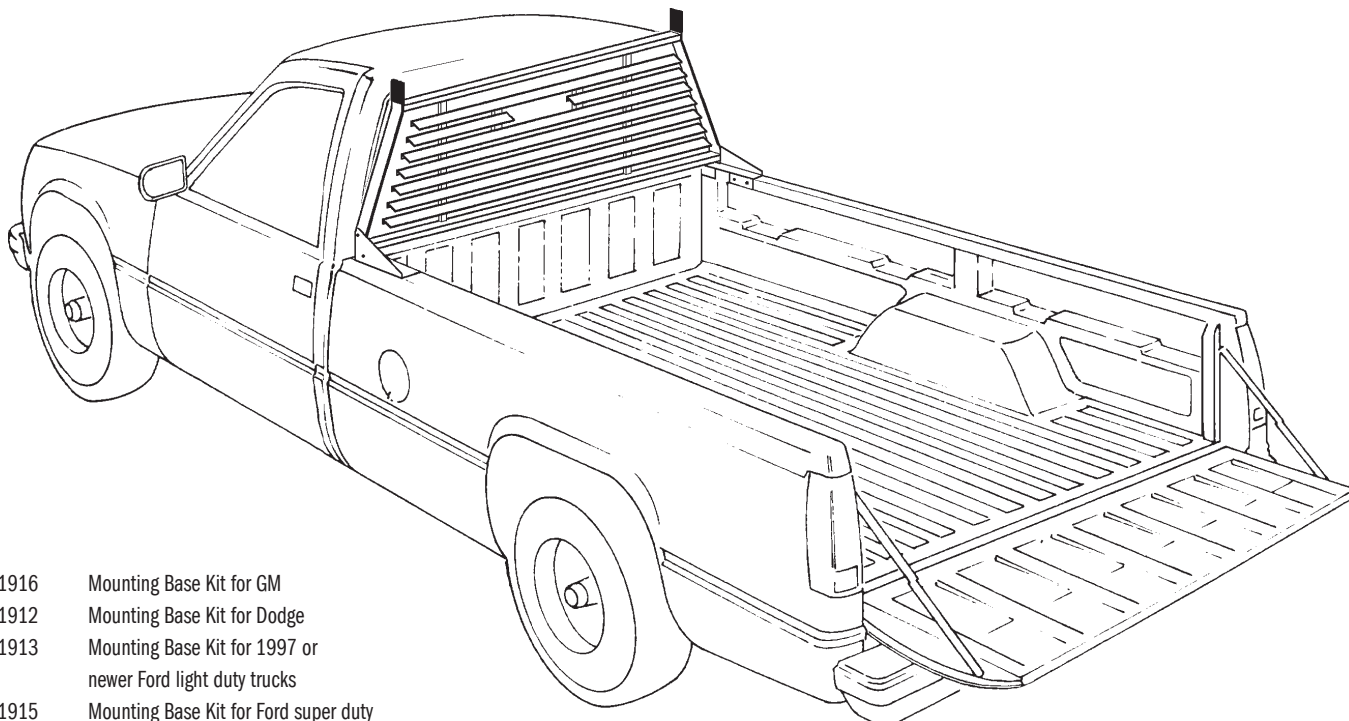

- 1916 Mounting Base Kit for GM
- 1912 Mounting Base Kit for Dodge
- 1913 Mounting Base Kit for 1997 or newer Ford light duty trucks
- 1915 Mounting Base Kit for Ford super duty and 1996 or older light duty trucks
- 1921 Mounting Base Kit for 5'7" Dodge Bed

⚠ NOTICE

Use specific aluminum upfit components when installing WEATHER GUARD® products to aluminum truck beds. Follow additional instructions if mounting to an aluminum truck bed. There may be left over components depending on upfit.

Any modification or unintended use of this product shall immediately void all manufacturers warranties. Manufacturer disclaims all liability for injuries to persons or property resulting from any modification to, or unintended use of this product.

⚠ DANGER

Any modifications made to, or unintended use of this product, could create a hazardous condition that can cause death, serious personal injury or property damage.

⚠ WARNING

Prior to drilling, so as not to cut or puncture fuel tanks, fuel lines, electric wires, etc., check under vehicle for locations. All floor mounting bolts near the gas tank area should be installed from the underside of the vehicle, to guard against the gas tank being punctured in the event of a collision. This would mean not using Blind Fastener in this area. Holes drilled in this area should be 3/8". This product can reduce the driver's ability to clearly see roadways, vehicular or pedestrian traffic and other objects through the rear and side windows of the vehicle, which may cause an accident. Extra precautions should be taken when driving a vehicle with this product. Make all adjustments necessary to ensure maximum visibility, including but not limited to, changing mirror or seating positions. State and local laws may prohibit obstruction or windows in a moving vehicle.











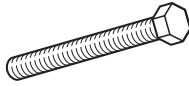

⚠ CAUTION

To keep debris out of your eyes when checking the underside of the vehicle, or when drilling, always wear protective eyewear.

TOOLS REQUIRED

- Electric Drill
- Drill Bits - 7/32", 1/4", 1/2"
- Open or Box End Wrenches - 7/16", 1/2", 9/16"
- 3/8" Drive Ratchet
- Sockets - 7/16", 1/2"
- C-clamp
- Utility Knife

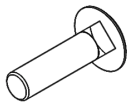
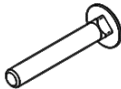
PARTS LIST

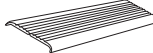
 (2) 5/16-18 x 1-1/4" Hex Head Bolt	 (4) 1/4-20 x 1-1/4" Hex Head Bolt	 (1) 5/16-18 x 2-1/4" Black Oxide Bolt	 (2) 5/16" Lock Washer	 (4) 5/16" Flat Washer
 (10) 1/4" Flat Washer	 (2) 5/16-18 Blind Fastener	 (1) Installation Tool	 (6) 1/4-20 Nylon Lock Nut	 (4) 5/16-18 Nylon Lock Nut
 (4) 5/16-18 x 1" Carriage Bolt	 (2) 1/4-20 x 1-1/2" Carriage Bolt	 (2) Shims	Note: The rubber mounting pad comes as a single piece and must be separated into two pieces, one for each side of the truck.  Rubber Mounting Pad	

ALUMINUM BED UPFIT KIT PARTS LIST - 32-0243

 (4) Vinyl Tape	 (1) Zinc Rich Primer	 (8) 1/2" x 1" Plastic Washer	 (4) 11/32" x 7/8" Plastic Washer	 (8) 5/16" x 3/4" Plastic Washer
--	--	--	--	---

BLIND FASTENER INSTALLATION

Place a drop of oil on black oxide bolt for lubrication before assembling.

Place the Blind Fastener in the hole and use 1/2" or 7/16" wrench to tighten black oxide bolt until fastener is fully seated (it will start out hard and get easier as fastener "bulbs" out).

Make sure the Blind Fastener and Installation Tool do not turn during installation.

ALUMINUM TRUCK BED INSTALLATION

Coat drilled holes with Zinc Rich Primer. Insert Blind Fastener through one 1/2" x 1" plastic washer. Insert Blind Fastener into drilled hole. Place second 1/2" x 1" plastic washer through the bottom of the Blind Fastener. Continue following installation instructions above to install Blind Fasteners.

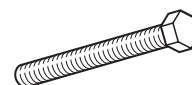

Black Oxide Bolt



Flat Washer

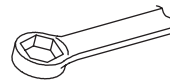

9/16" Wrench

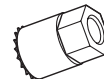

Installation Tool



Blind Fastener

INSTALLATION INSTRUCTIONS

Note: If your truck bed is constructed of aluminum, use zinc rich primer to coat drilled holes.

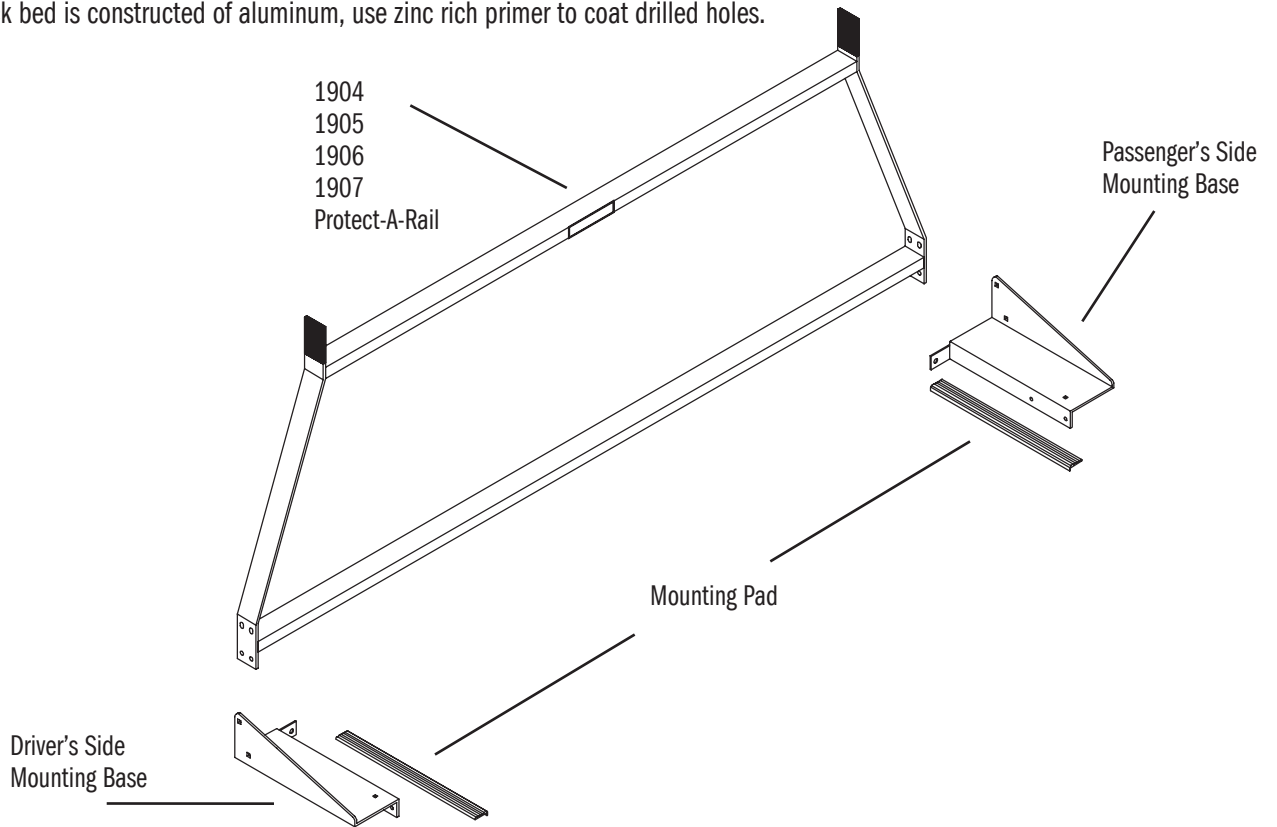

PERFORM THE FOLLOWING STEPS TO THE DRIVER SIDE & PASSENGER SIDE

STEP 1 Protect-A-Rail to Mounting Base Procedure

Place frame of unit between the bases and install fasteners (snug but do not tighten at this time).

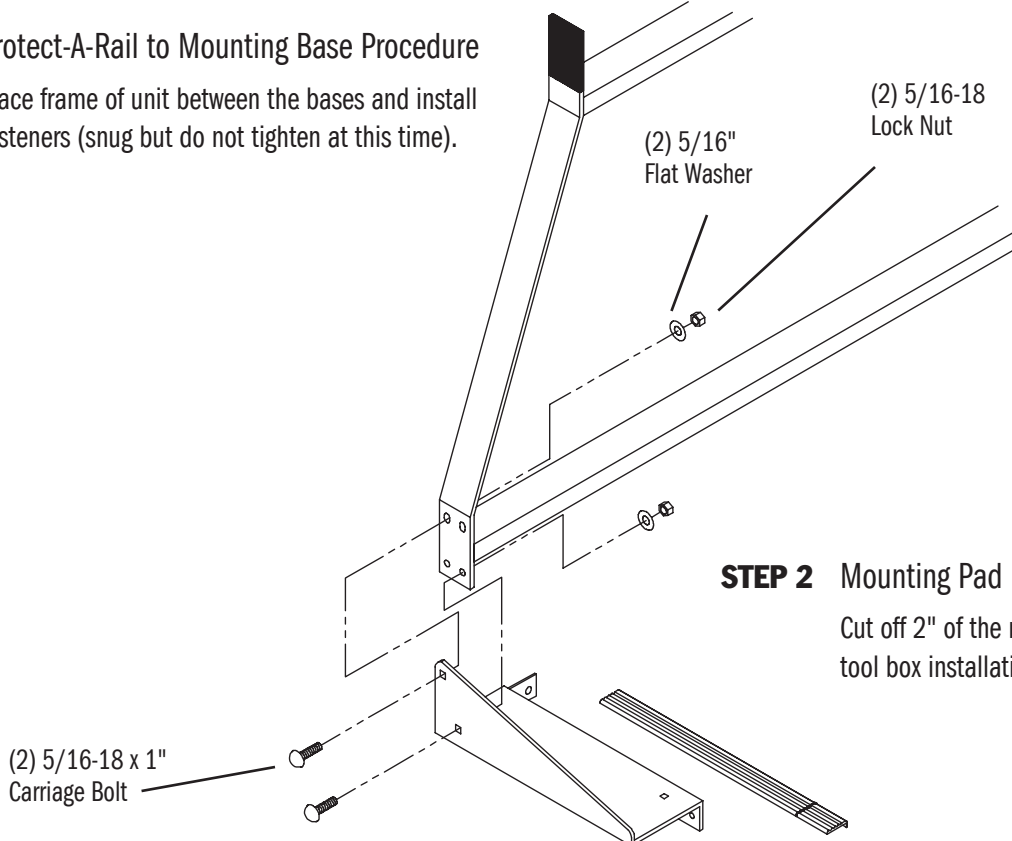

STEP 2 Mounting Pad

Cut off 2" of the mounting pad and save for tool box installation.

STEP 3 Protect-A-Rail Location

Note: - Remove any plastic tabs from the under side of the truck top tail that are in the way.

Tape washer, clamp, and drill top, side, and front (with mounting pads in places).

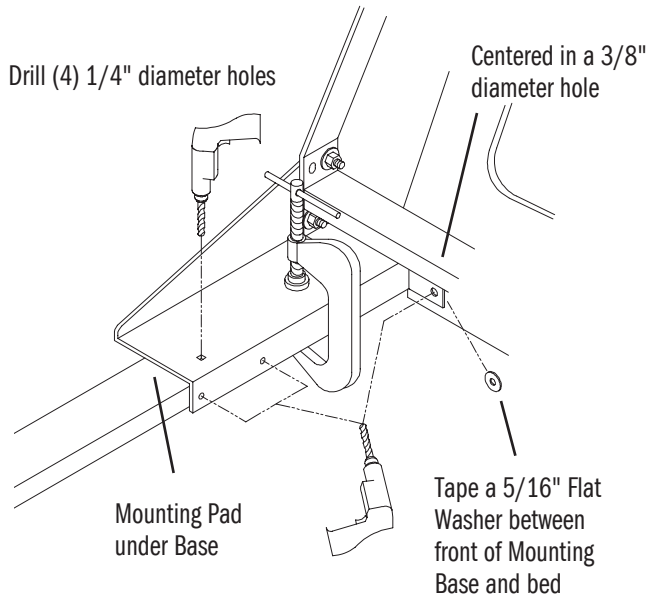

STEP 4 Re-drill Procedure

Unclamp, move Protect-A-Rail, remove flat washer, re-drill front hole, and install Blind Fastener.

ALUMINUM TRUCK BED INSTALLATION:

Follow additional instructions if mounting to an aluminum truck bed as explained in the Blind Fastener Installation on page 2.

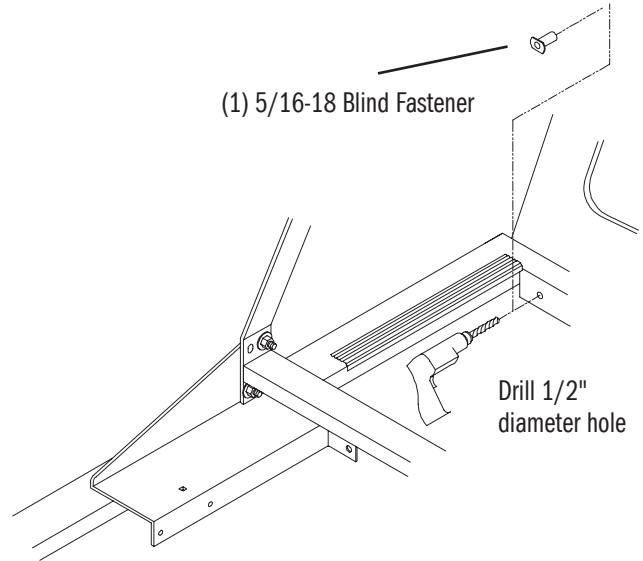

STEP 5 Protect-A-Rail Installation

Replace rack and install top, side, and front fasteners (tighten all fasteners).

ALUMINUM TRUCK BED INSTALLATION:

Use one 5/16" x 3/4" plastic washer as a barrier between the 1/4" flat washer and the aluminum truck bed.

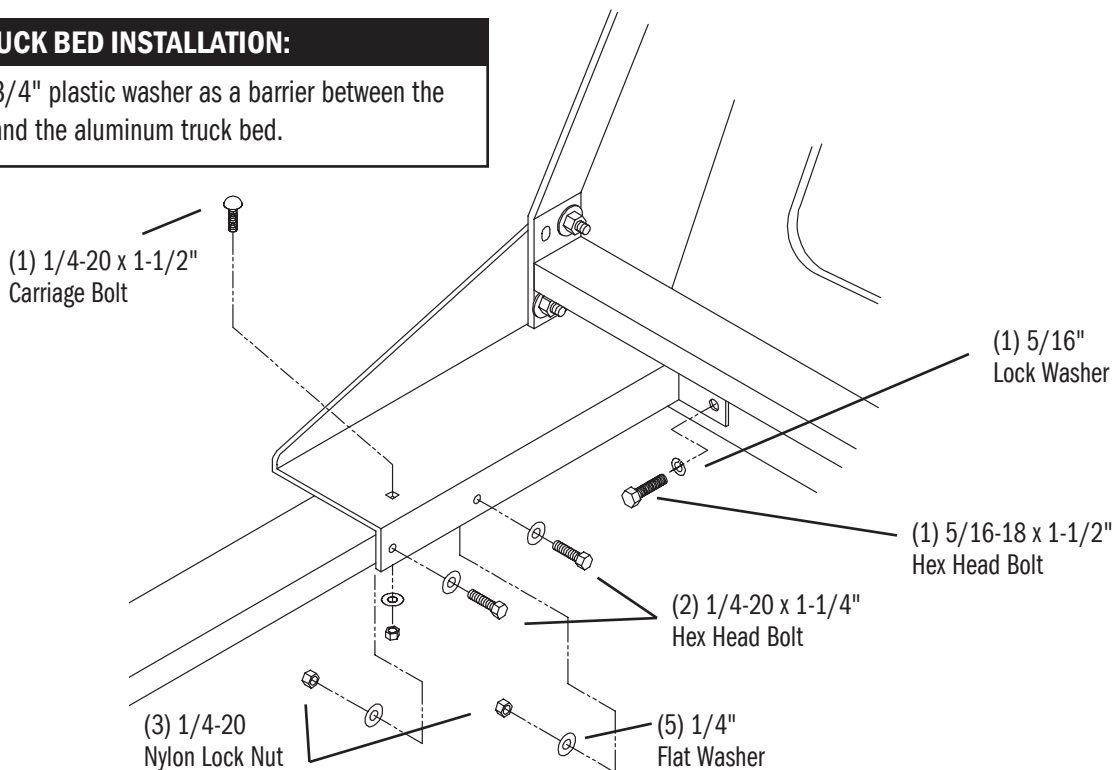

STEP 6 (Optional) Cross, Saddle and Side Box Mounting Procedure

If a truck mounted box is to be used with the Protect-A-Rail, use the 3/16" thick shims that are provided along with the 2" mounting pads that were cut off in Step 1. This will ensure a level mounting of the box. Make sure the box cover(s) can be fully opened without hitting the louvered Protect-A-Rail. Check to make sure all fasteners are tight.

ALUMINUM TRUCK BED INSTALLATION:

Use vinyl tape as a barrier between the "J" Bolt and truck bed.

