



**TRUCK STORAGE SOLUTIONS**  
SECURING YOUR REPUTATION®

# INSTALLATION MANUAL

## ALUMINUM & STEEL PORK CHOP BOX

**ATTENTION: PLEASE READ AND UNDERSTAND ALL INSTRUCTIONS AND WARNINGS BEFORE ASSEMBLING, INSTALLING OR USING THIS PRODUCT.**

**MODELS** 160-X-01, 161-X-01, 162-X-01, 163-X-01, 170-X-01, 171-X-01, 172-X-01, 173-X-01

**Note:** X represents the color code for your model: 0 = Clear | 3 = White | 5 = Black



### ⚠ NOTICE

Use specific aluminum upfit components when installing WEATHER GUARD® products to aluminum truck beds. Follow additional instructions if mounting to an aluminum truck bed. There may be left over components depending on upfit.

Any modification or unintended use of this product shall immediately void all manufacturers warranties. Manufacturer disclaims all liability for injuries to persons or property resulting from any modification to, or unintended use of this product.

### ⚠ DANGER

Danger of explosion. Do not use this product for storing or transporting flammables, explosives, hazardous materials, or hazardous waste, such as containers of gasoline, solvents, gun powder, dynamite, propane tanks, acetylene tanks and cutting torches. This product is only intended and safe for use in storing and transporting small tools, equipment and other similar materials. Any modifications made to, or unintended use of this product, could create a hazardous condition that can cause death, serious personal injury or property damage.

### ⚠ WARNING

Prior to drilling, so as not to cut or puncture fuel tanks, fuel lines, electric wires, etc., check under vehicle for locations. All floor mounting bolts near the gas tank area should be installed from the underside of the vehicle, to guard against the gas tank being punctured in the event of a collision. This would mean not using Blind Fastener in this area. Holes drilled in this area should be 3/8".









### ⚠ CAUTION

Before marking the leg mounting holes, check inside the box for location of gas spring housing and components that may obstruct safe drilling. To keep debris out of your eyes when checking the underside of the vehicle, or when drilling, always wear protective eyewear.

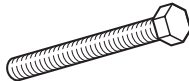
## TOOLS REQUIRED

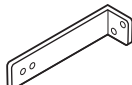
- Electric Drill
- Drill Bits - 3/16", 3/8", 1/2"
- Open or Box End Wrenches - (2) 1/2", 9/16"
- Hammer
- Oil/Grease
- Center Punch
- Carpenter's Square
- Pencil/Marker

## PARTS LIST

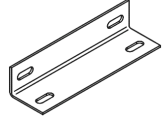
 (6) 5/16-18 x 1" Hex Head Bolt	 (3) 5/16-18 x 1-1/4" Hex Head Bolt	 (1) 5/16-18 x 2-1/4" Black Oxide Bolt	 (3) 5/16" Lock Washer	 (14) 5/16" Flat Washer
 (2) Mounting Angle	 (3) 5/16-18 Blind Fastener	 (1) Installation Tool	 (6) 5/16-18 Nylon Lock Nut	 (2) Floor Mounting Spacer
 (1) Floor Mounting Angle				

## ALUMINUM BED UPFIT KIT PARTS LIST - 32-0243

 (4) Vinyl Tape	 (1) Zinc Rich Primer	 (8) 1/2" x 1" Plastic Washer	 (4) 11/32" x 7/8" Plastic Washer	 (8) 5/16" x 3/4" Plastic Washer
--	--	--	--	---

## BLIND FASTENER INSTALLATION

Place a drop of oil on black oxide bolt for lubrication before assembling.

Place the Blind Fastener in the hole and use 1/2" or 7/16" wrench to tighten black oxide bolt until fastener is fully seated (it will start out hard and get easier as fastener "bulbs" out).

Make sure the Blind Fastener and Installation Tool do not turn during installation.



**Black Oxide Bolt**



**Flat Washer**



**9/16" Wrench**

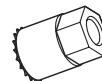

**Installation Tool**



**Blind Fastener**

## ALUMINUM TRUCK BED INSTALLATION

Coat drilled holes with Zinc Rich Primer. Insert Blind Fastener through one 1/2" x 1" plastic washer. Insert Blind Fastener into drilled hole. Place second 1/2" x 1" plastic washer through the bottom of the Blind Fastener. Continue following installation instructions above to install Blind Fasteners.

# INSTALLATION INSTRUCTIONS

- Note:**
- If your truck bed is constructed of aluminum, use zinc rich primer to coat drilled holes.
  - If your pickup is fitted with a plastic drop-in bed liner, it may need to be drilled, trimmed, or cut for proper installation of truck box.
  - Truck box cover may not properly latch until box is fully bolted to truck bed.
  - Periodically check tightness of mounting bolts to ensure proper attachment.
  - Use touch-up paint on any drilled holes to prevent oxidation.
  - Install boxes with vehicle parked on level ground.

## STEP 1 Locate Box in Truck Bed

**Note:** · Fasten box and leg mounting feet directly to bed floor, not bed liners or mats.

Place box into position with cover open. Support box as required during installation. Verify tailgate closes with mounting angle in position. Bottom of box should be flat on the floor. Side of box (not cover) should be approximately 1" from bed rail.

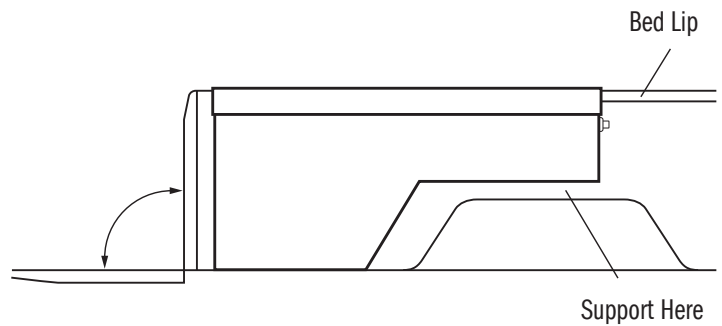

### ALUMINUM TRUCK BED INSTALLATION:

Use vinyl tape as a barrier between the mounting clamp and truck bed. Follow same instructions if mounting with a "J" bolt.

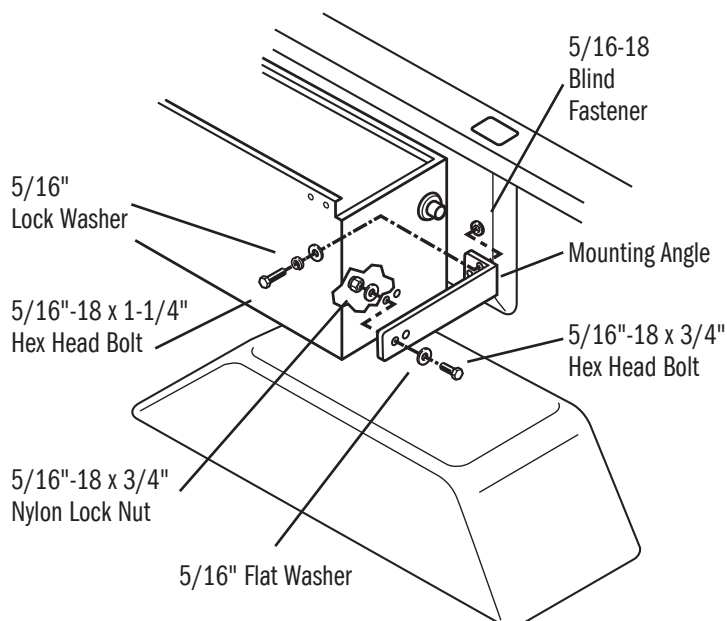

## STEP 2 Attach End Mounting Angle

**Note:** · This step may be omitted if you are able to use the alternate method in Step 3A. Make sure there is enough hole depth before installing the blind fastener.

Place mounting angle against end of box with foot touching stake pocket (or inner wall of truck bed). Mark one hole on the box and one hole on the truck. Center punch the holes to be drilled. Drill truck box and stake pocket (or inner wall) with 3/16" drill bit. Re-drill hole in truck box with 3/8" drill bit. Re-drill hole in stake pocket (or inner wall) with 1/2" drill bit. Install Blind Fastener in stake pocket (or inner wall). Install mounting angle.

### ALUMINUM TRUCK BED INSTALLATION:

Follow additional instructions if mounting to an aluminum truck bed as explained in the Blind Fastener Installation on page 2.

### STEP 3A Attach Lower Mounting Angle

- Note:** · Install bolts from underside when fastening mounting angle to wheel well.
- This step may be omitted if you are able to use the alternate method.

Place mounting angle under box and against wheel well. Mark one hole on bottom of box and both holes on wheel well. Center punch the holes to be drilled. Drill truck box and wheel well with 3/16" drill bit. Install mounting bracket.

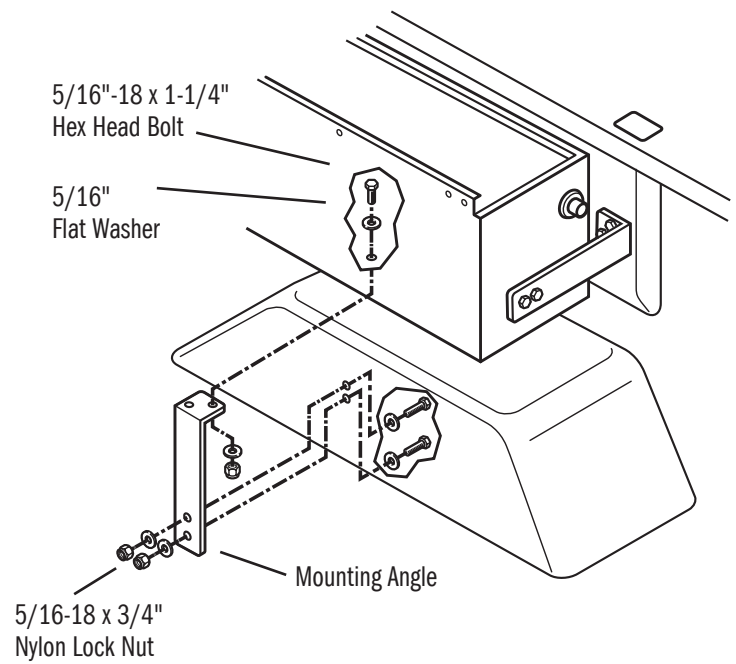

#### ALUMINUM TRUCK BED INSTALLATION:

Follow additional instructions if mounting to an aluminum truck bed as explained in the Blind Fastener Installation on page 2.

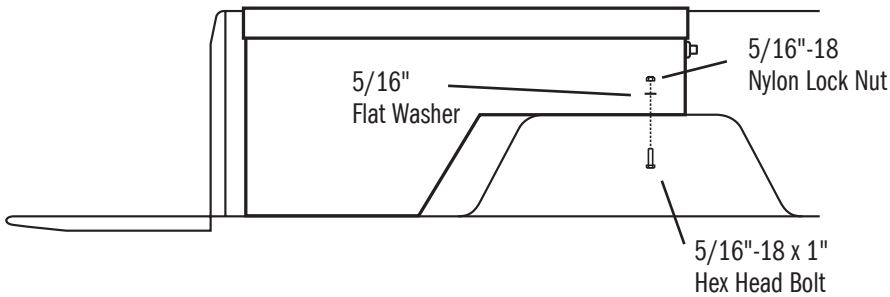

### STEP 3B Alternate Mounting Method

- Note:** · Install bolts from underside when fastening Mounting Angle to wheel well.

Use if truck configuration allows box to rest directly on wheel well. Mark, center punch and drill 3/16" hole in bottom of box and top of wheel well shown in the figure to the right. Re-drill holes with 3/8" drill bit. Install bolt as shown in figure to the left.

#### ALUMINUM TRUCK BED INSTALLATION:

Follow additional instructions if mounting to an aluminum truck bed as explained in the Blind Fastener Installation on page 2.

### STEP 4 Attach Floor Mounting Angle

- Note:** · If holes in Floor Mounting Angle are not positioned above rib, use Floor Mounting Spacers provided.

Place floor mounting angle on floor, centered behind the box. Mark, center punch and drill all four holes with 3/16" drill bit. Re-drill holes in box with a 3/8" drill bit. Re-drill holes in truck bed with 1/2" drill bit. Install Blind Fasteners in truck bed. Install floor mounting angle as shown in figure to the right.

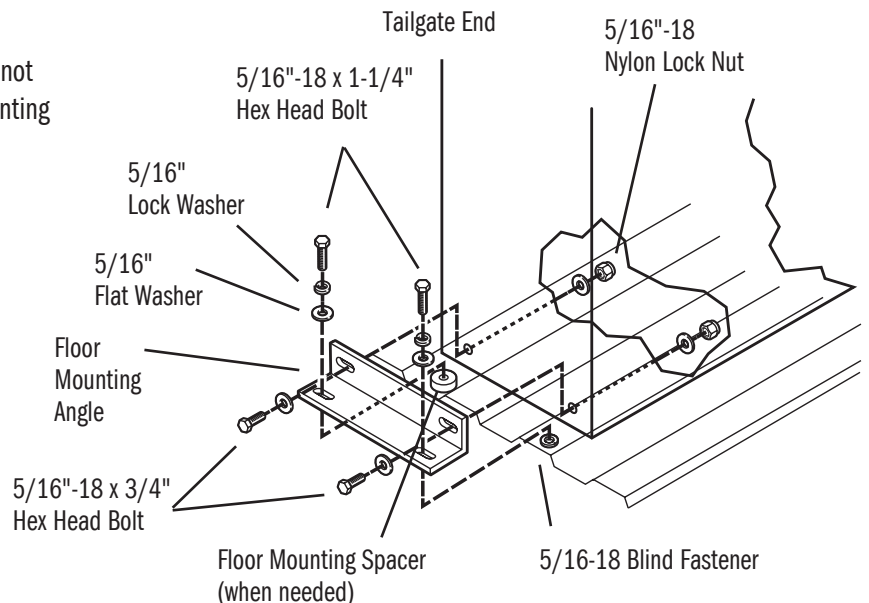

## FEATURE OPERATION

### Lock System

The WEATHER GUARD® Extreme Protection™ Lock is designed to provide maximum security, while providing ease of use and years of reliable service. When in the locked mode, the button remains retracted in a tamper-resistant position. When the button is pressed in the unlock mode, the latches are activated and the cover opens.

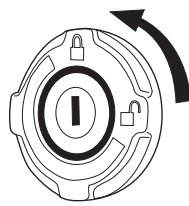

#### Lock

Turn the key counterclockwise to the locked position as indicated on the lock bezel. When the button is now pressed, it will stay in the retracted or tamper-resistant position until unlocked.

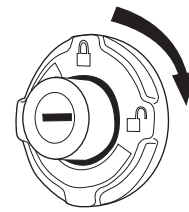

#### Unlock

Turn the key clockwise to the unlocked position as indicated on the lock bezel. Button will pop out and is now ready to release the latches when pressed.

### Latch System

The WEATHER GUARD® Latch System utilizes automotive grade latches in conjunction with high strength latch strikers to ensure maximum security. The WEATHER GUARD® Latch System is designed to open with a single touch of the button, and close securely. Expect years of reliable service from the WEATHER GUARD® Latch System with only minimal maintenance: Lubricate latch pivot points bi-annually with white grease. If latch strikers are accidentally knocked out of alignment, simply use a mallet to re-align.

## SERVICE PARTS

#	PART #	DESCRIPTION	FITS MODEL #
1	7095	Gas Spring	170-X-01, 171-X-01, 172-X-01, 173-X-01
1	7096	Gas Spring	162-X-01, 163-X-01
2	7748-XX	Lock & Key Set (XX = key code) (1 lock, 2 keys, retainer clip)	All Pork Chop
3	7750-XX	Key Replacement (XX = key code ) (2 keys)	All Pork Chop
4	7731	Latch & Striker Kit (1 latch, 1 striker, mounting hardware)	All Pork Chop
5	7106	Striker Kit (1 striker and mounting hardware)	All Pork Chop
6	7730	Weather Strip Kit (various styles for one box)	All Pork Chop
7	7735-X	Mounting Kit	All Pork Chop
8	7746	Nameplate Kit (3 stickers, 2 side bezels, 1 back bezel)	All Pork Chop
9	7788-X	Cover	170-X-01
9	7789-X	Cover	171-X-01
9	7790-X	Cover	172-X-01
9	7795-X	Cover	173-X-01
9	7726-X	Cover	160-X-01
9	7827-X	Cover	161-X-01
9	7828-X	Cover	162-X-01
9	7832-X	Cover	163-X-01
10	7738	Latch Rod Kit (not shown)	160-X-01, 162-X-01, 170-X-01, 172-X-01
10	7739	Latch Rod Kit (not shown)	161-X-01, 163-X-01, 171-X-01, 173-X-01

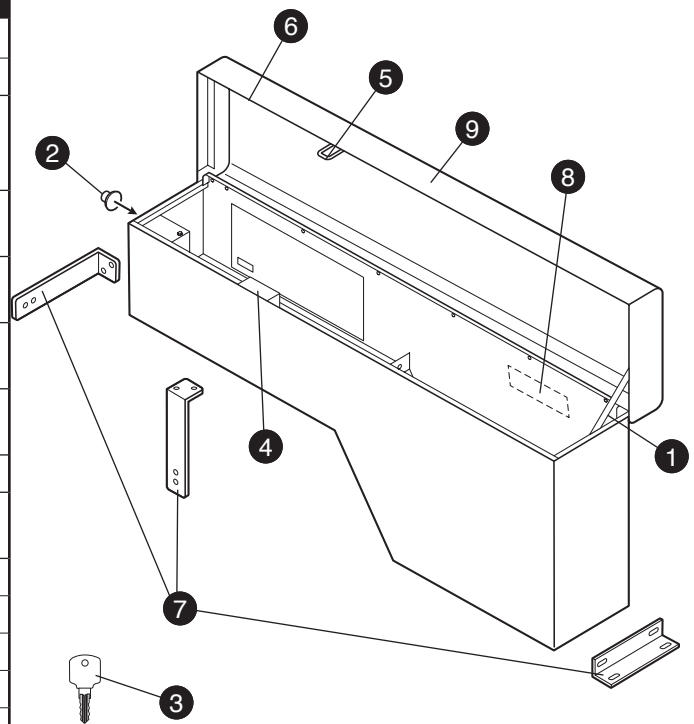

**Note:** X represents the color code for your model:  
0 = Clear | 3 = White | 5 = Black