



TRUCK STORAGE SOLUTIONS
SECURING YOUR REPUTATION®

INSTALLATION MANUAL WEEKENDER® STEEL LADDER RACK

ATTENTION: PLEASE READ AND UNDERSTAND ALL INSTRUCTIONS AND WARNINGS BEFORE ASSEMBLING, INSTALLING OR USING THIS PRODUCT.

MODELS 1450, 1475

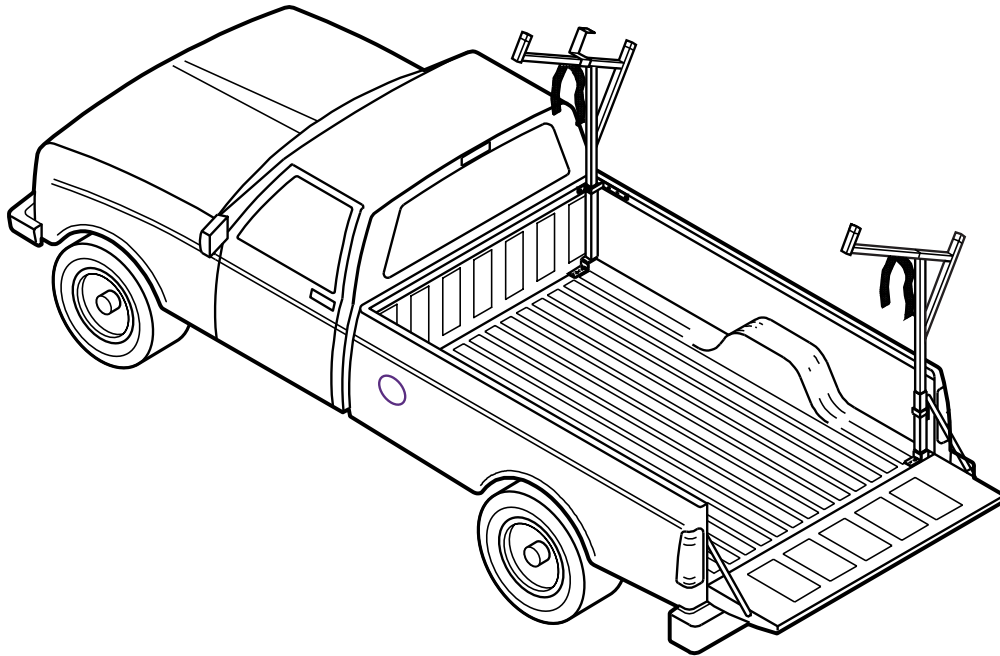

1475 shown

⚠ NOTICE

Use specific aluminum upfit components when installing WEATHER GUARD® products to aluminum truck beds. Follow additional instructions if mounting to an aluminum truck bed. There may be left over components depending on upfit.

Any modification or unintended use of this product shall immediately void all manufacturers warranties. Manufacturer disclaims all liability for injuries to persons or property resulting from any modification to, or unintended use of this product. Do not seal uprights to the leg socket seams. It is strongly suggested that the upright assemblies be removed and stored when not in use. Warranty will be void if sealant is not properly applied to all seams.

⚠ CAUTION

Before marking the leg mounting holes, check inside the box for location of gas spring housing and components that may obstruct safe drilling. To keep debris out of your eyes when checking the underside of the vehicle, or when drilling, always wear protective eyewear. To prevent resonant vibration damage during vehicle operation with an unloaded rack, leg assemblies should be removed.

This product is only intended for, and only safe for, transporting ladders, lumber, pipe and other similar materials. It is the responsibility of the user of this rack to secure these materials to the rack before transporting. Any modifications made to this product for any other purpose than its intended use could create a hazardous condition that can cause serious personal injury or property damage.

⚠ DANGER

Danger of explosion. Do not use this product for storing or transporting flammables, explosives, hazardous materials, or hazardous waste, such as containers of gasoline, solvents, gun powder, dynamite, propane tanks, acetylene tanks and cutting torches. This product is only intended and safe for use in storing and transporting small tools, equipment and other similar materials. Any modifications made to, or unintended use of this product, could create a hazardous condition that can cause death, serious personal injury or property damage.

⚠ WARNING





















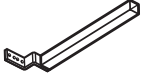
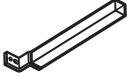

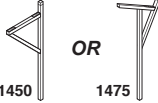

Prior to drilling, so as not to cut or puncture fuel tanks, fuel lines, electric wires, etc., check under vehicle for locations. All floor mounting bolts near the gas tank area should be installed from the underside of the vehicle, to guard against the gas tank being punctured in the event of a collision. This would mean not using Blind Fastener in this area. Holes drilled in this area should be 3/8".

Ladders must be secured per ANSI standard A14.2-1990 paragraph 8.4.4. Ladder damage will occur from road shock and vehicle vibration if the ladder and/or materials are not secured to the rack. Bouncing and side-to-side motion of an improperly secured ladder will cause wear and weaken the ladder. Using a damaged ladder could lead to a structural collapse and could result in serious injury or death.

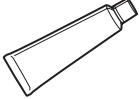
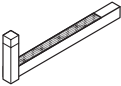
TOOLS REQUIRED

- Electric Drill, 1/2" Chuck
- Bits: 1/2", 7/32"
- Open or Box End Wrench - 1/2", 9/16", 3/8"
- Screwdriver (flat head)
- Framing Square
- Level
- Hack Saw
- Center Punch
- Tape Measure

PARTS LIST

 (9) 5/16-18 Blind Fastener	 (1) Installation Tool	 (2) 5/16-18 x 1" Hex Head Bolt	 (9) 5/16-18 x 1-1/4" Hex Head Bolt	 (1) 5/16-18 x 2-1/4" Black Oxide Bolt
 (4) #10 Flat Washer	 (15) 5/16" Flat Washer	 (1) 3/8" Flat Washer	 (4) 10-24 Nylon Lock Nut	 (3) 3/8-16 Nylon Lock Nut
 (1) Front Leg Socket	 (1) Rear Leg Socket	 (1) Ladder Stop	 (2) Ladder Strap	 (9) 5/16" Lock Washer
 (1) Floor Mounting Spacer	 (1) Front Mounting Bracket	 (1) Rear Mounting Bracket	 1450 OR 1475 (2) Upright	 (1) 3/8-16 x 3-1/4" Carriage Bolt
 (1) Silicone Sealant Tube	 (2) Extension	 (1) F-150 Adapter	 (2) 3/8-16 x 1" Thread Cut Bolt	 (4) #10-24 x 2-3/4" Machine Screw
 (2) Plastic Rope Cleat	 (3) 3/8-16 x 3/4" Thread Cutting Bolt			

ALUMINUM BED UPFIT KIT PARTS LIST - 32-0244

 (4) Vinyl Tape	 (1) Zinc Rich Primer	 (28) 1/2" x 1" Plastic Washer	 (4) 11/32" x 7/8" Plastic Washer	
--	--	---	--	--

BLIND FASTENER INSTALLATION

Place a drop of oil on black oxide bolt for lubrication before assembling.

Place the Blind Fastener in the hole and use 1/2" or 7/16" wrench to tighten black oxide bolt until fastener is fully seated (it will start out hard and get easier as fastener "bulbs" out).

Make sure the Blind Fastener and Installation Tool do not turn during installation.

ALUMINUM TRUCK BED INSTALLATION

Coat drilled holes with Zinc Rich Primer. Insert Blind Fastener through one 1/2" x 1" plastic washer. Insert Blind Fastener into drilled hole. Place second 1/2" x 1" plastic washer through the bottom of the Blind Fastener. Continue following installation instructions above to install Blind Fasteners.



Black Oxide Bolt



Flat Washer

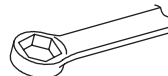

9/16" Wrench

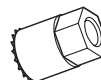

Installation Tool



Blind Fastener

STEEL WEEKENDER® RACK ASSEMBLY

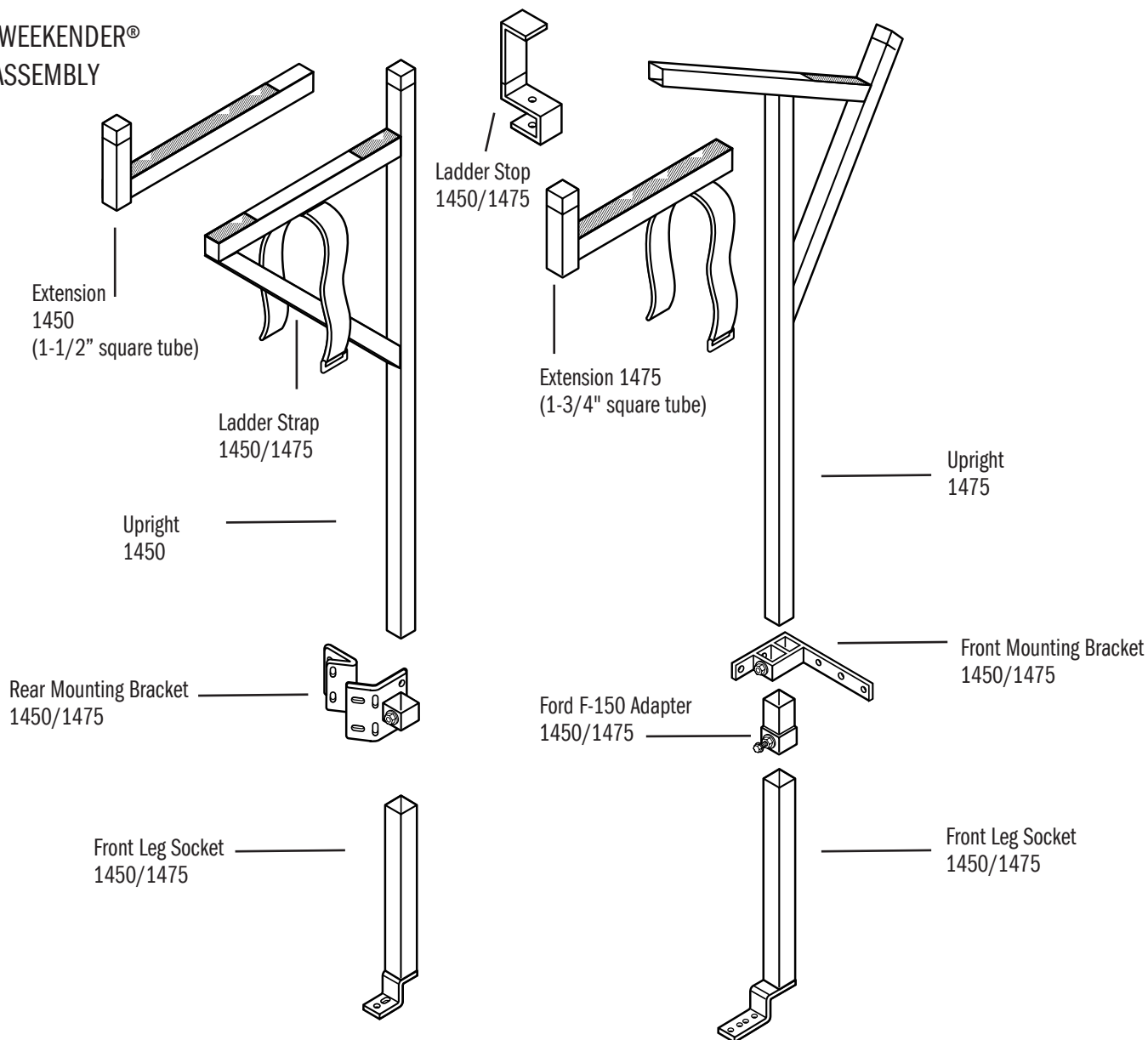

INSTALLATION INSTRUCTIONS

Note: If your truck bed is constructed of aluminum, use zinc rich primer to coat drilled holes.

STEP 1 Mounting the Front Leg Socket

- Note:**
- The illustrations show installation on the passenger side of the vehicle. For installation on the driver side, simply reverse the parts.
 - If the pickup has a bed liner, the liner may need to be drilled, trimmed or cut for proper installation of the product.
 - The best mounting hole location is between floor ribs. A floor spacer and/or two extra 5/16" washers have been provided to fill the void. If possible, rotate the leg socket assembly 90 degrees to the rear of the vehicle.

If installing on a 2004 Ford F-150 and newer vehicle, place the F-150 Adaptor onto the front leg socket. Install and tighten a 3/8-16 x 1" thread cutting bolt into the adaptor to make a mark on the front leg socket. Remove adaptor and drill a 7/16" pilot hole and then a 1/2" hole at the indentation mark of the thread cutting bolt on the leg socket. Re-install the F150 adaptor onto the front leg socket. Do not tighten the thread cutting bolt at this time.

Insert the front leg socket into the front mounting bracket as shown in the figure below. Hold the mounting bracket flush with the top rail of the truck bed ensuring the front leg socket assembly is plumb and square to the truck bed.

Mark and center punch the four holes of the front mounting bracket and front leg socket foot (see note above for mounting to the truck bed floor).

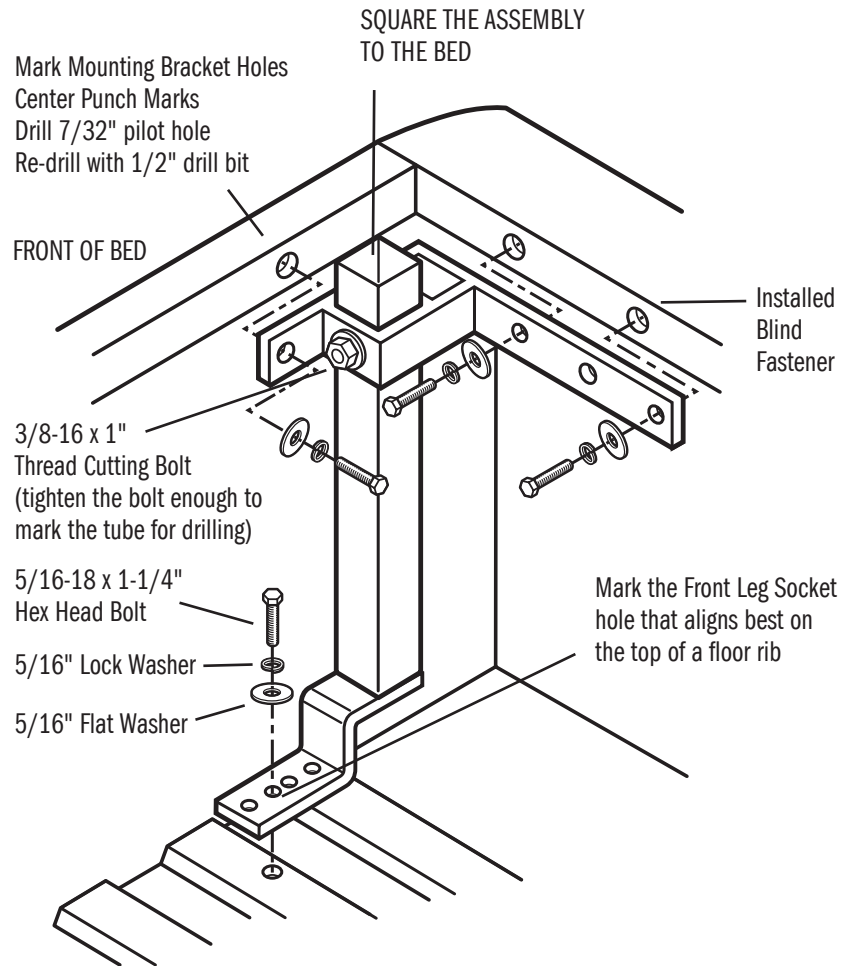
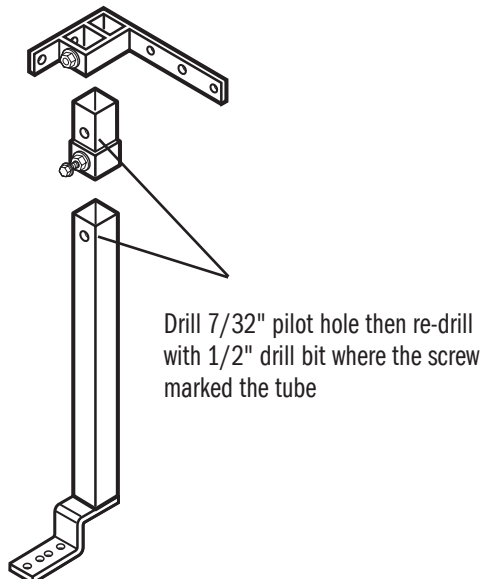

Drill a pilot hole with a 7/32" drill bit in each marked hole. Then re-drill the holes with a 1/2" drill bit. Install blind fasteners into each drilled hole.

ALUMINUM TRUCK BED INSTALLATION:

Follow additional instructions if mounting to an aluminum truck bed as explained in the Blind Fastener Installation on page 3.

Take the front leg socket assembly, four 5/16-18 x 1-1/4" hex head bolts, four 5/16" lock washers and four 5/16" flat washers and install as shown above. Tighten all screws at this point ensuring assembly is square and plumb to the truck.

Take a 3/8-16 x 1" thread cutting bolt and install into the front mounting bracket. Tighten the thread cutting bolt enough to mark the front leg socket for drilling.

Disassemble the front leg socket assembly, take the front leg socket and drill a pilot hole with a 7/32" drill bit through the mark created in the previous step by the thread cutting bolt. Then re-drill the hole with a 1/2" drill bit. Reassemble the front leg socket assembly to the truck bed tightening all hardware except the 3/8-16 x 1" thread cutting bolt.

STEP 2A Mounting the Rear Leg Socket (90° Degree Tailgate Stop)

Note: · Skip Step 2A and proceed to Step 2B if you own a Toyota Tacoma, Chevy Colorado, or GMC Canyon with a 45-degree tail-gate stop.

- If the best mounting hole location is between floor ribs, a floor spacer and/or two extra 5/16" flat washers have been provided to fill the void or rotate the leg socket 90° to the rear of the vehicle if possible.

Using the 5/16-18 x 1" hex head bolts, washers, and nylon lock nuts fasten the rear mounting bracket plate 1 and 2 together. The long end of the angle on plate 2 faces away from plate 1.

Insert the rear leg socket into the rear mounting bracket assembly. Hold the mounting bracket assembly flush with the tailgate stop ensuring that the rear leg is plumb and square to the truck bed.

Mark the five holes. Remove the assembly and center punch each of the holes. Drill a 7/32" pilot hole, then re-drill each hole using a 1/2" drill bit.

Install blind fasteners into each drilled hole.

ALUMINUM TRUCK BED INSTALLATION:

Follow additional instructions if mounting to an aluminum truck bed as explained in the Blind Fastener Installation on page 3.

Take the rear leg socket assembly, four 5/16-18 x 1-1/4" hex head bolts, four 5/16" lock washers and four 5/16" flat washers and install as shown in figure below. (It may be necessary to dis-assemble rear mounting bracket plate 1 and 2 in order to fasten plate 2 to the truck). Tighten all fasteners at this time on the rear mounting bracket.

Take a 3/8-16 x 1" thread cutting bolt and install into the rear mounting bracket as shown in the figure below. Tighten the thread cutting bolt enough in order to mark the rear leg socket for drilling.

Disassemble the rear leg socket assembly taking the rear leg socket and drill a 7/32" pilot hole through the mark created in the previous step with the thread cutting bolt. Then re-drill the hole using a 1/2" drill bit. Reassemble the rear leg socket assembly to the truck bed tightening all hardware except the 3/8-16 x 1" thread cutting bolt.

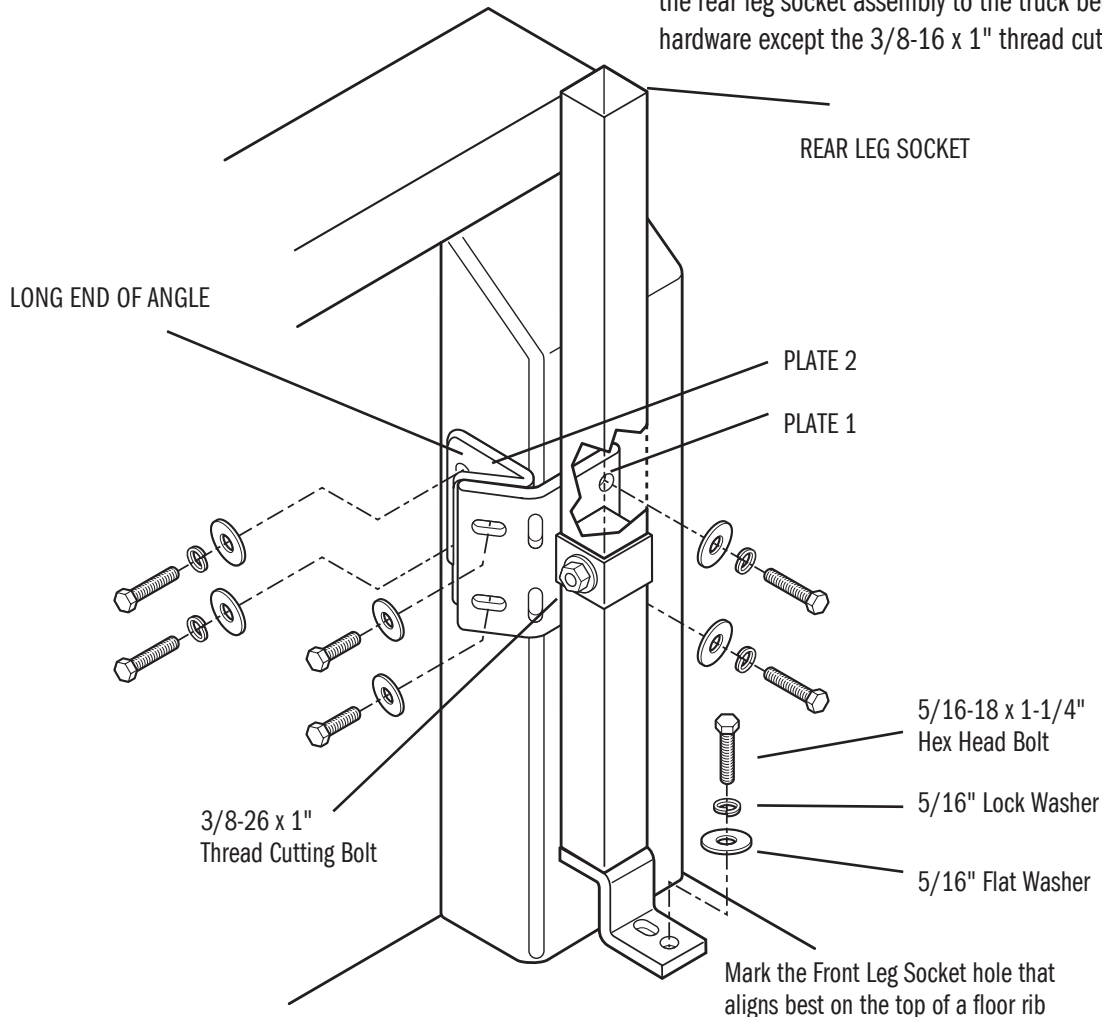

STEP 2B Mounting the Rear Leg Socket (45° Degree Tailgate Stop)

- Note:**
- For Toyota Tacoma, Chevy Colorado, or GMC Canyon with a 45-degree tail-gate stop.
 - If the best mounting hole location is between floor ribs, a floor spacer and/or two extra 5/16" flat washers have been provided to fill the void. Or rotate the leg socket 90° to the rear of the vehicle if possible.

Insert the rear leg socket into the rear mounting bracket plate 1 as seen in figure below (plate 2 will not be used). Hold the mounting bracket assembly flush with the tailgate stop ensuring that the rear leg is plumb and square to the truck bed.

Mark the five holes. Remove the assembly and center punch each of the holes. Drill a 7/32" pilot hole, then re-drill each hole using a 1/2" drill bit.

Install blind fasteners into each drilled hole.

ALUMINUM TRUCK BED INSTALLATION:

Follow additional instructions if mounting to an aluminum truck bed as explained in the Blind Fastener Installation on page 3.

Take the rear leg socket assembly, four 5/16-18 x 1-1/4" hex head bolts, four 5/16" lock washers and four 5/16" flat washers and install as seen in Figure below. Tighten all fasteners at this time on the rear-mounting bracket.

Take a 3/8-16 x 1" thread cutting bolt and install into the rear mounting bracket as shown in the figure below. Tighten the thread cutting bolt enough to mark the front leg socket for drilling. Disassemble the rear leg socket assembly taking the rear leg socket and drill a 7/32" pilot hole through the mark created in the previous step with the thread cutting bolt. Then re-drill the hole using a 1/2" drill bit. Reassemble the rear leg socket assembly to the truck bed tightening all hardware except the 3/8-16 x 1" thread cutting bolt.

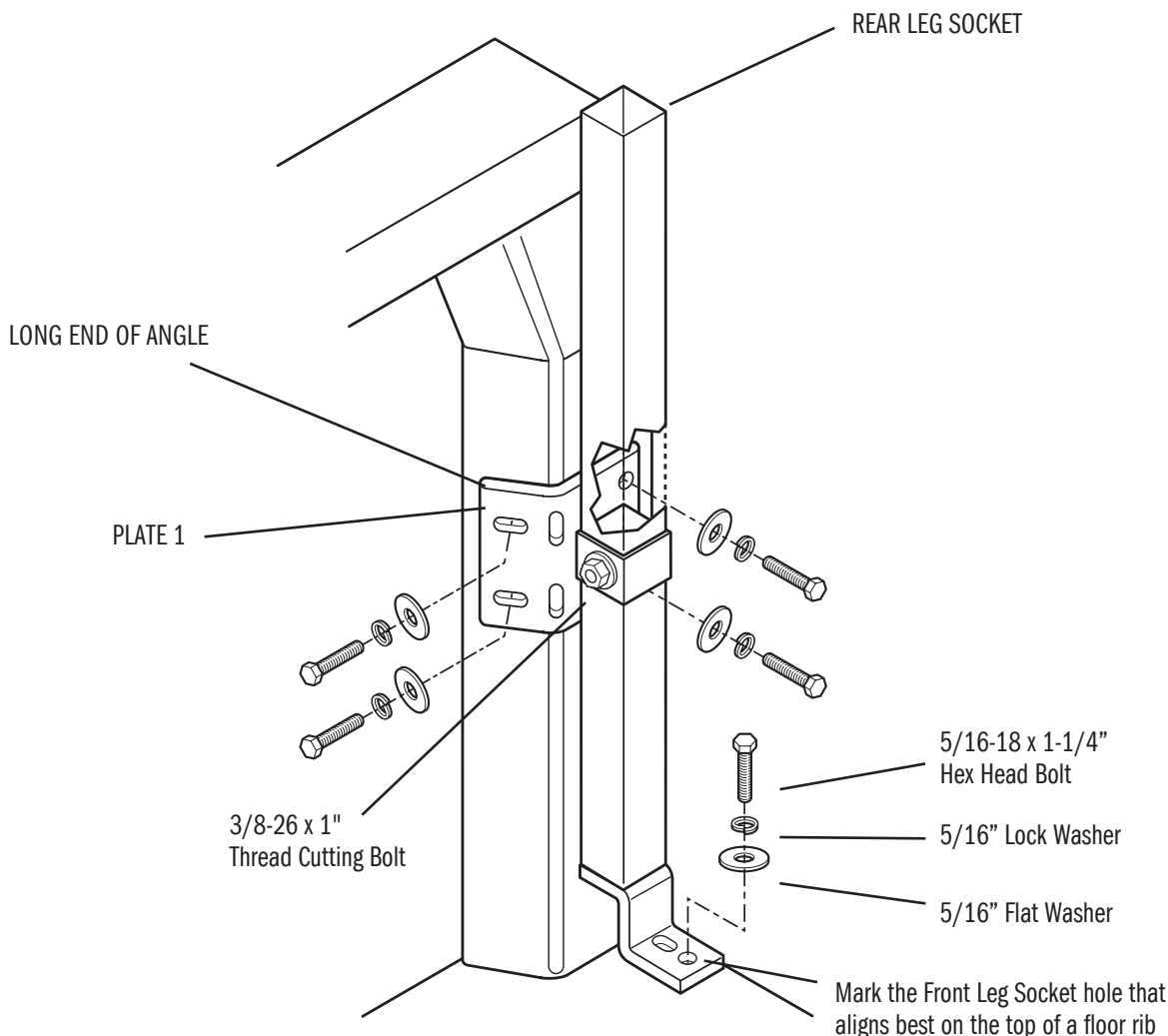

STEP 3 Installing the Front Upright

Take one upright and insert into the front leg socket assembly. Tighten the 3/8-16 x 1" thread cutting bolt installed in Step 1 in the front mounting bracket. Take one extension and insert it into the upright. After tightening at the desired location, seal the joint between the two tubes with the provided silicone sealant. Take the ladder stop, one 3/8-16 x 3/4" carriage bolt, one 3/8" flat washer and one 3/8-16 nylon lock nut and install onto the upright. Take the one strap and install it onto the bracket.

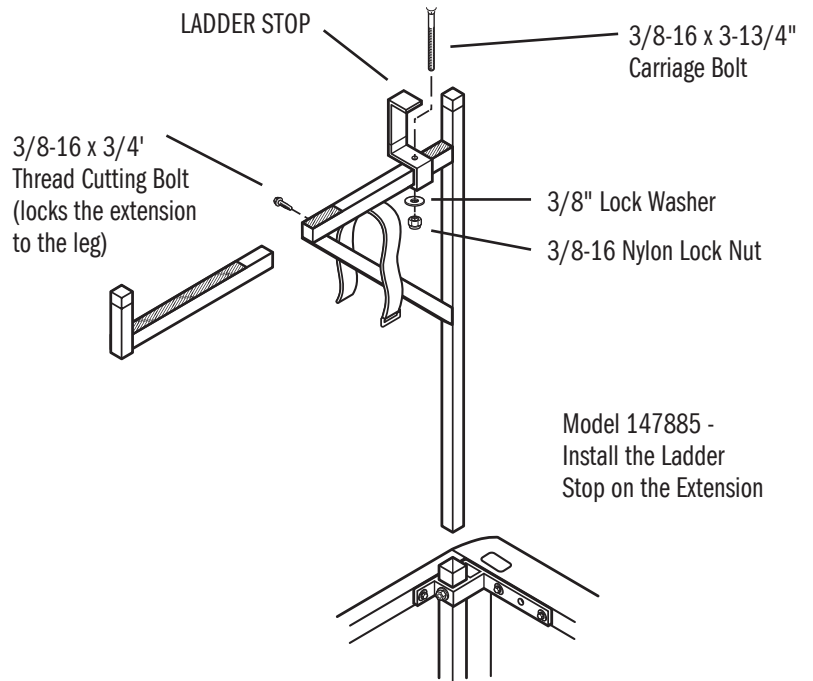

STEP 4 Installing the Rear Upright

Take the remaining upright and insert into the rear leg socket assembly. Tighten the 3/8-16 x 1" thread cutting bolt installed in Step 2 in the rear mounting bracket.

Take the remaining extension and insert it into the upright as shown in Step 3. After tightening at the desired location, seal the joint between the two tubes with the provided silicone sealant. Take the remaining ladder strap and install it onto the bracket as shown in Step 3.

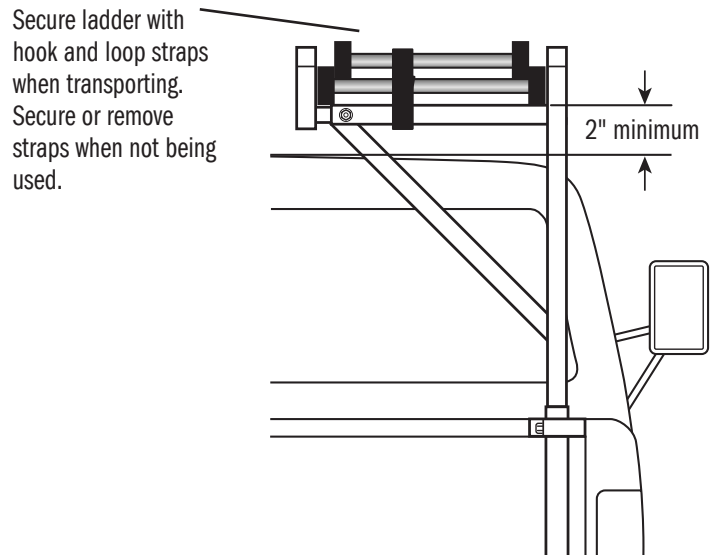

STEP 5 Installing the Rope Cleats

The two rope cleats are to be mounted where desired on the upright.

Apply sealant around holes before assembling.

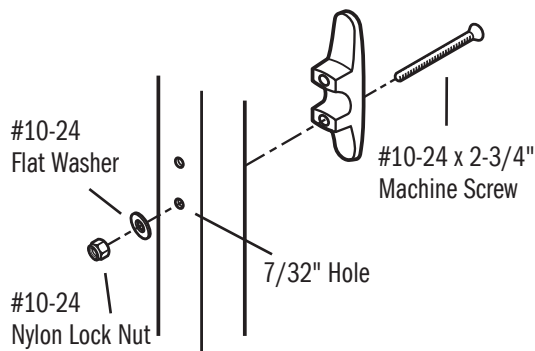

STEP 6 Securing a Ladder to the Rack

Carefully place a ladder on the rack, and check door entry and head clearance. If clearance is ample, and if desired, the uprights may be shortened as long as a minimum of 2" above the cab roof is maintained, see Step 4. Remove and cut the uprights if desired. Note that you need to cut from the bottom of the upright. Double check the measurement before cutting. Secure ladder with the provided ladder straps when transporting. Secure or remove ladder straps when not being used.