



Protecting Your Adventure Lifestyle

SR 180-4 SYSTEM **SUZUKI SAMURAI** INSTALLATION INSTRUCTIONS

***** READ ALL INSTRUCTIONS BEFORE BEGINNING INSTALLATION*****

To install your WARRIOR SR 180 SYSTEM, be sure your SUZUKI is on a level surface before removal of front wheels and tires. You will need jack stands or a way to support your axle and your chassis before you begin installing your new kit. If you have after market springs you must verify your vehicle wheel base. The original location of your diff housing is very important, so measure your wheel base before beginning any work. Remember, your new kit was designed to fit with all factory springs. Aftermarket springs may alter this wheelbase and your new kit may have to be adjusted accordingly. Please read the instructions completely and understand all the provisions before you begin. **CALL IF YOU HAVE AFTERMARKET LEAF SPRINGS!** We will be glad to assist you.

*****ALL WELDING MUST BE DONE BY A CERTIFIED WELDER*****

- 1) Document all necessary measurements and make notes before jacking vehicle and removing wheels.
- 2) Jack up front of vehicle and put on frame supports (jack stands). Locate the stands behind the rear of the front leaf springs and securely on the frame to suspend entire front of vehicle off the ground. Be certain vehicle is level and secure. Shake vehicle to confirm it is stable.
- 3) Remove front wheels for ease of installation.
- 4) Remove front u-bolts (4). Raise front housing up and out of your way with a floor jack and support diff housing with additional jack stands.
- 5) You should now be able to remove both front leaf springs completely from the vehicle. Your stock spring bushings are not to be replaced with your kit. If you have purchased after market poly bushings, replace them at this time.
- 6) Remove both front shackle brackets from your front cross member and frame member. Clean frame area thoroughly for welding purposes and ease of installation of your WARRIOR front cross member.



Protecting Your Adventure Lifestyle

-
- 7) Install WARRIOR front cross member to the frame horns. Clamp bar in place so it is centered left to right on the frame horns. The 3 1/4" x 2 1/2" plate on the top of the WARRIOR cross member must align with the end of your stock vehicle frame, see illustration number #A included.

*****IF YOU ARE IN DOUBT, CALL FACTORY BEFORE WELDING*****

- 8) Weld front cross member in place according to illustration number #C included.

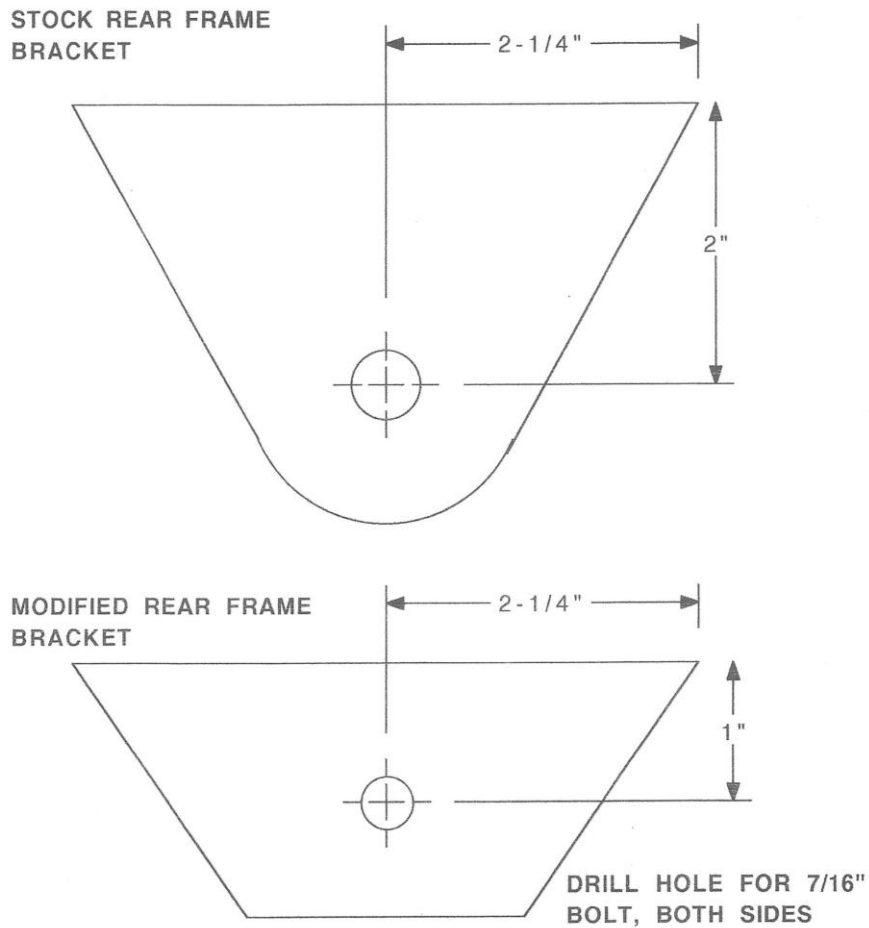



Protecting Your Adventure Lifestyle

-
- 9) The rear brackets must be modified, see illustration number #B included. NOTE: The rear bracket can be left with no modification if you wish more lift and more negative caster. Remember that after market leaf springs may change the angle of your rear shackle. Call if you feel there is a problem as per illustration number #D included.

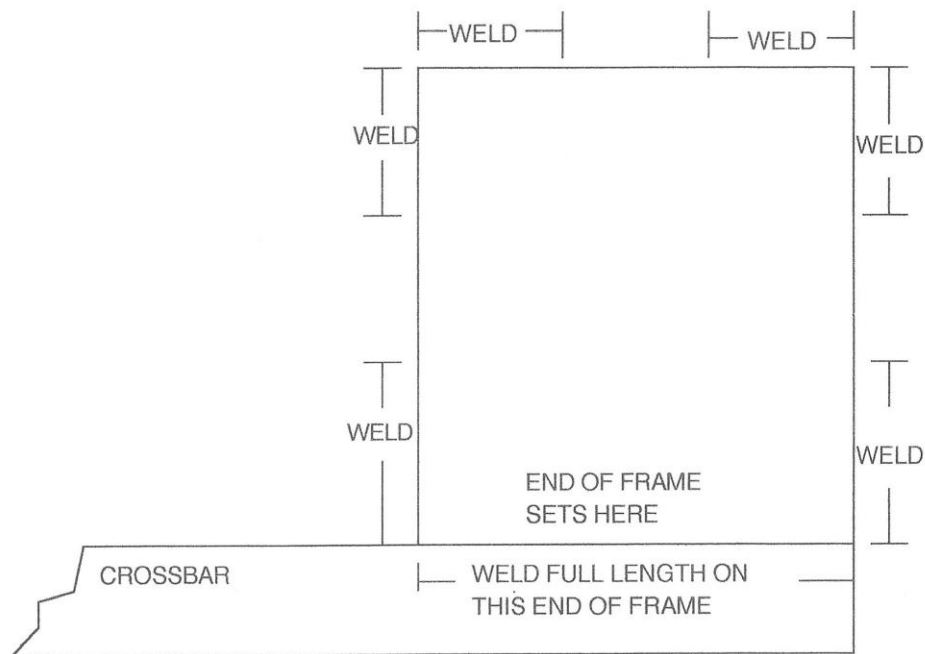

LOOKING DOWN AT THE TOP OF CROSS BAR WITH BOTH BRACKETS, DRIVERS SIDE. DO NOT MAKE CONTINUOUS WELDS

- 10) Install front portion of front leaf spring in WARRIOR cross bar using the supplied shoulder bolts. Do not tighten bolts at this time.
- 11) Install rear WARRIOR “Y” type shackles to frame, narrow end points up, with supplied bushings and a 7/16” bolt supplied; raise rear of leaf springs into the “Y” shackle, install lower bolt ½” supplied. Hand tighten bolts and nuts until you have put weight back on vehicle.
- 12) Lower front housing onto leaf springs, be sure leaf spring locating pin is in correct location, reinstall front u-bolts, replace all that were stripped upon removal, not supplied in kit, torque to factory specifications.



Protecting Your Adventure Lifestyle

-
- 13) Install front wheels and tires, tighten to factory specifications.
 - 14) Lower vehicle to floor and tighten front cross member nut to 45ft.lbs. Tighten top shackle bolt and nut to 45ft. lbs. Tighten lower shackle to 55ft. lbs.
 - 15) Check all bolts for tightness, yes again.
 - 16) Test drive. Please re-torque all bolts for tightness and inspect all welds for fractures after your initial test drive and again after five hundred miles.
 - 17) Enjoy the way your SUZUKI SAMURAI now drives with your new SR-180 SYSTEM.

*****ALL WELDING MUST BE DONE BY A CERTIFIED WELDER*****

