



## Toyota FJ Cruiser Steel LED Tail Lights

P/N 3965

### Kit Contents:

<u>Item</u>	<u>Qty</u>	<u>Item</u>	<u>Qty</u>
Steel Light Housing pair (L&R)	1	2 ½" Diameter Large Washer	2
Red rectangular Stop/Turn/Tail LED light (w/hardware)	2	1/4" Hex Nut	14
White rectangular Reverse LED light (w/hardware)	2	1/4" SAE Flat Washer	8
Red 1" round Side Marker light	4	1/4" x 2" Carriage Bolt	6
3-wire to 2-wire Converter	1	Edge Trim	72"
Nylon Misalignment spacer	8	"P" Trim	18"

### Notes before you start:

**Disclaimer:** Warrior has developed this Tail Light kit keeping general motor vehicle requirements in mind; however, requirements can change from state-to-state. It is your responsibility to confirm that you are in compliance with local laws and regulations. Warrior Products is not responsible for any damages or costs incurred as a result of the installation of this Tail Light kit.

1. "Ratcheting" type combination wrenches, while not required, will make installation much easier, you will need 10mm and 7/16".
2. Your kit contains three different types of LED lights. LED lights are polarity sensitive and will only illuminate if connected correctly (i.e. ground (-) to ground (-), and positive (+) to positive (+). The three types of LED's in your kit and the wire colors are described below:
  - a. Red rectangular Stop/Turn/Tail LED light – Three wires coming out of the back;
    - **Ground (-)** = WHITE
    - **Bright Circuit (+) – Stop/Turn** = RED
    - **Dim Circuit (+) - Tail Light** = BLACK
  - b. White rectangular Reverse LED light – Two wires coming out of the back;
    - **Ground (-)** = WHITE
    - **Positive (+)** = BLACK
  - c. Red 1" round Side Marker light – Two wires coming out of the back;
    - **Ground (-)** = WHITE / RED STRIPE
    - **Positive (+)** = BROWN
3. The factory FJ Cruiser tail lights are operated by a 3-wire tail light system (the turn signal light, and the brake light are indicated by separate bulbs on each side). This Tail Light kit uses a combined signal for the Stop and Turn indication (which is a 2-wire tail light system.) You will have to install the included 3-wire to 2-wire tail light converter (or Trailer Wiring Converter) to complete the installation. The input side of the converter will take the signal from your existing factory bulb socket wires, and the output side of the converter will be connected to the Red lights of the Warrior Products Tail Light system. The White Reverse lights can be connected directly to the factory reverse bulb socket wires. You will need to add some additional length to some of the converter wires (not included) to complete the installation. Additionally, there are many different ways to make wire connections. We have left it up to you to decide which method to use, therefore, these instructions will simply tell you which wires to connect.
4. You will most likely experience a "fast blinker" or "hyper blinker" symptom as a result of installing LED Tail Lights. This symptom is a result of the lower power consumption of the LED bulb vs. the factory Incandescent bulb. To correct the "fast blinker" symptom, we recommend replacing your flasher module with one that has been designated as "compatible for LED use". You can find various options with a quick internet search, or you can visit your local auto parts store. We have successfully installed a NAPA auto parts flasher (Part # NF LM449) to correct the issue. Please note that the installation of this type of flasher module will eliminate the "fast blinker" warning to notify you when a signal bulb has burnt out. Please periodically check your signal lights to confirm that all are functioning correctly.

## Installation Procedure:

1. Prepare your Warrior Products Steel LED Tail Lights by installing and wiring the LED lights included in your kit. Perform the steps below for one light fixture, then repeat the procedure for the second light.
  - a. Insert two of the Red 1" Side Marker lights by threading the wires through the  $\frac{3}{4}$ " holes from the outside, and simply press into place. (See **Figure 1**).

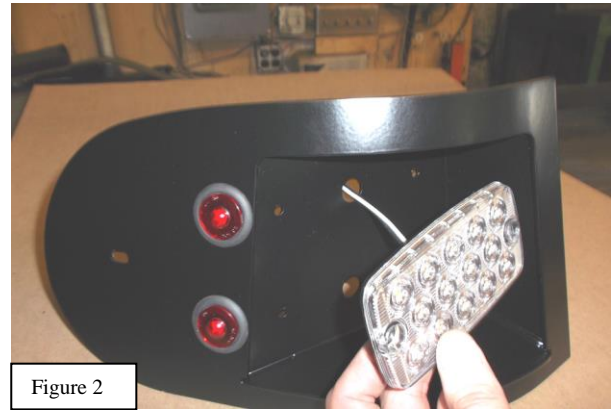
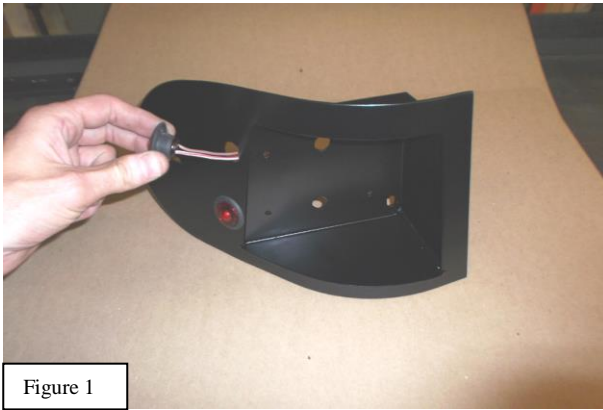

- b. Next, mount one Red rectangular S/T/T light, and one White rectangular Reverse light in the undercut portion of the fixture as shown with the provided screws and nuts (you may choose your configuration, with the reverse on the top, or reverse on the bottom, the lights are interchangeable with the mounting locations.) Again, thread the wires through the holes provided from the outside of the fixture as shown in **Figure 2**. The screw holes in the fixture may be tight due to the powder coat, if so, you should be able to screw them through before placing the nut on the back side. **Tamper resistant screw covers are provided, which are one-time use caps. Do not install these caps until after you are completely satisfied with placement/configuration of your lights. You may also choose to not use the caps at all if that is your preference.** It is possible to pry the caps out with a razor blade tip, or other sharp instrument if necessary, but this can be dangerous and may chip the plastic of the caps and/or lights.
- c. After you have mounted the lights to the fixture, the next step is to wire the fixture prior to connecting the wiring to the vehicle. Refer to **Figure 3** as a guide.

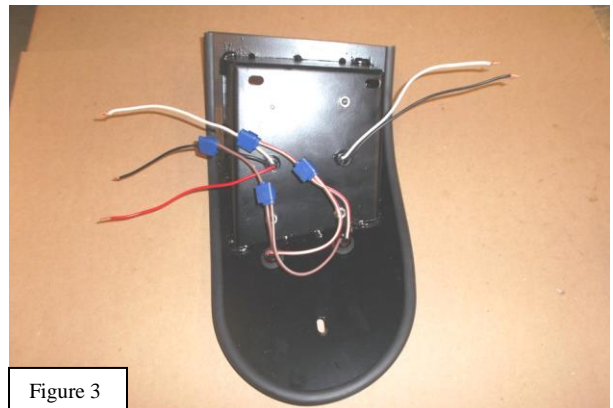

- i. The White Reverse light will connect directly to the existing reverse circuit.
  - ii. The side marker lights will be connected to the "marker light" or "tail light" circuit. To do this, connect the White/Red stripe wire of one Red 1" light to the White/Red Stripe wire of the other Red 1" light. Connect these wires to the White ground wire of the Red rectangular S/T/T light. Repeat the procedure connecting the Brown wires of the Red 1" lights together with the Black wire of the Red rectangular S/T/T light. You can see in **Figure 3**, we have chosen to "daisy chain" the wires together.
- d. Complete preparation of the Steel Tail light fixture by applying the included edge trim around the long continuous edge (do not place edge trim on the vertical edge closest to the rear cargo door). Cut off excess trim. See **Figure 4**.



2. Next, remove your factory tail lights. Each light has three mounting studs attaching it to the vehicle. You must access the nuts from the inside of the vehicle cargo area (This is where a "ratcheting" style combination wrench is helpful). There is a small

QUALITY



INTEGRITY



INNOVATION



SERVICE

access cover which can be pried open with a flat edged tool directly behind each light that will give you access to two of the three nuts. The third nut can be accessed through a lower opening near the floor on the passenger side, and through the jack storage area on the driver side (please note that the factory subwoofer, or rear power port may require additional disassembly to gain access to the passenger tail light mounting nuts). The side nuts are hidden from sight and positioned toward the side of the vehicle, which comparatively, is different from the other two positioned toward the back of the vehicle. Reach out to the outer body sheet metal, then up, where you should be able to feel a protruding mounting stud.

- After removing the Factory tail lights, remove the side post receivers from the sheet metal by removing the two screws and pulling the plastic away from the sheet metal. See **Figure 5**.

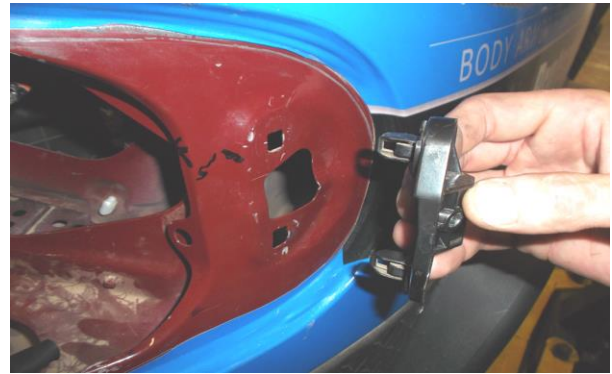
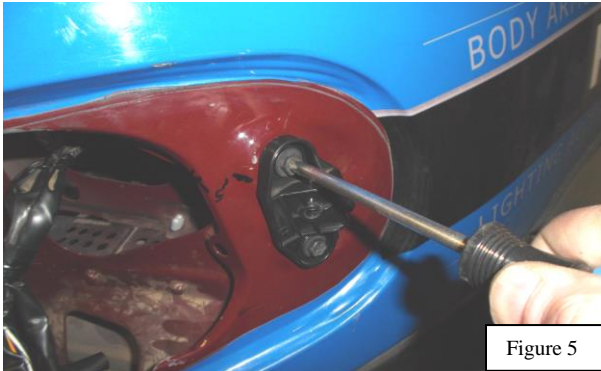

- Now, the 3-wire to 2-wire converter must be installed. As mentioned above, it is your responsibility to choose which method you prefer for your wire connections and splices. To install the converter, you should remove the lower plastic threshold below the rear gate by removing the (5) Philips head screws, then gently pulling upward on the plastic trim starting at one end. This is where you can run wires across the vehicle. See **Figure 6**.



- Loosen, or remove the cargo area side panels as required to gain sufficient access to place the converter box and wires. There are two Phillips head screws under the plastic trim that you just removed, and you may have to remove the cargo "tie down lugs" for more access. Factory subwoofers may require more effort to gain access.
- After you have gained sufficient access for wiring, choose a side of the vehicle to place the converter box. You will eventually have to run two wires (one input and one output) across the vehicle and you will have to add additional length to the converter box wires to achieve this. We have placed the converter box on the driver side for our installation.

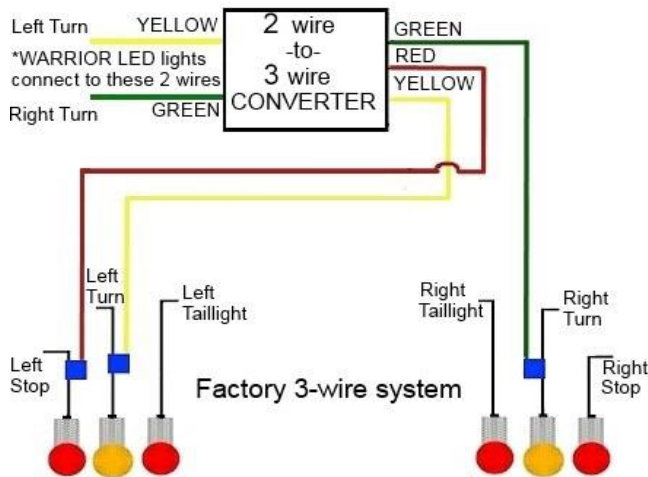

- You will now connect the wires for the input (3-wire) side of the converter (Refer to the diagram below).

FJ Cruiser / OEM / Factory Wires	3-wire to 2-wire Converter Wires
Blue w/white stripe (Driver side only) = Left Turn (+)	Yellow (+) "TO CAR"
Green w/yellow stripe = Brake (+)	Red (+) "TO CAR"
Pink (Passenger side only) = Right Turn (+)	Green (+) "TO CAR"

- First, connect the yellow "TO CAR" wire of the converter to the FJ Cruiser Blue wire with white stripe at the Left Turn signal socket. This is the two-wire socket with an amber bulb.
- Next, pick up the Brake signal by connecting

the Red "TO CAR" wire of the converter to the FJ Cruiser green with yellow stripe wire for the brake. The green with yellow stripe wire will be connected to the only bulb socket in the factory tail light with three wires. This connection can be made on either the passenger OR the driver side.

- c. The third wire to connect is for the Right Turn signal. Connect the Green “TO CAR” wire of the converter to the pink FJ Cruiser wire on the passenger side tail light sockets. Similar to the driver side, you will connect to the pink turn signal wire will be connected to the socket with the amber bulb.
8. Before you wire the connections to your new LED lights, quickly check for any interference with the LED Tail light housing and the FJ Cruiser body sheet metal on the passenger side. Hold the housing into the opening and try to feel if it is contacting the latch support reinforcement (passenger side only.) See **Figure 7**. If you believe that you may have contact, or just want to make sure, you can lightly shave the top flange of the reinforcement with a die grinder, file, hacksaw blade, or other. If you file this flange down, make sure to paint the exposed metal to prevent any future rust.



Figure 7

Check this flange for contact.

### WIRE CONNECTION CHART (4-wire system to LED Tail Light boxes)

#### Driver Side

LED Light Wires	Vehicle wires – OR – Converter Box Wires
Reverse Light – BLACK (+)	Vehicle Bulb Socket – RED w/YELLOW stripe (+)
Reverse Light – WHITE (-)	Vehicle Bulb Socket – WHITE w/BLACK stripe (-)
Red S/T/T Lights – “Bright Circuit” RED (+)	<b>Converter Box Wire – YELLOW (+) “TO TRAILER” side – Left Turn and Stop</b>
Red S/T/T Lights – “Dim Circuit” BLACK (+)	Vehicle Bulb Socket – GREEN (+) *Driver side
Red S/T/T Lights – “Ground” White (-)	Vehicle Bulb Socket – WHITE w/BLACK stripe (-) *Driver side

#### Passenger Side

LED Light Wires	Vehicle wires – OR – Converter Box Wires
Reverse Light – BLACK (+)	Vehicle Bulb Socket – RED w/YELLOW stripe (+)
Reverse Light – WHITE (-)	Vehicle Bulb Socket – WHITE w/BLACK stripe (-)
Red S/T/T Lights – “Bright Circuit” RED (+)	<b>Converter Box Wire – GREEN (+) “TO TRAILER” side – Right Turn and Stop</b>
Red S/T/T Lights – “Dim Circuit” BLACK (+)	Vehicle Bulb Socket – GREEN (+) *Passenger side
Red S/T/T Lights – “Ground” White (-)	Vehicle Bulb Socket – WHITE w/BLACK stripe (-) *Passenger side

9. Now that the converter is wired to the vehicle, you now need to connect the 2-wire (output) side to your new LED lights. The converter will only be used to control the red wires on the red lights of the kit. The white reverse lights can be connected directly to wires of the FJ Cruiser reverse light socket. We suggest before fully mounting the tail light boxes that you check the functionality of lights to confirm that you have made all of the correct connections and that everything functions as expected (refer to Wire Connection chart above). Remember, if you have not yet changed your flasher to an “LED compatible” flasher, you may experience the “fast blinker” symptom. Run your wires from the inside of the vehicle through the tail light openings and support your new Warrior Tail Light boxes while you make the connections. Tuck the wires in as you mount the lights to the vehicle. The chart above indicates the additional connections to be made at the tail lights. The YELLOW wire on the output side of the converter “TO TRAILER” will ONLY run to the driver side of the vehicle for the Stop/Left Turn function, and the GREEN “TO TRAILER” wire of the converter will ONLY run to the passenger side of the vehicle for the Stop/Right Turn function.
10. Before mounting your new Tail light assemblies, remove the paper to expose adhesive backing, then place a piece of “P” trim cut to length (approx. 7”) along the inside vertical edge of the opening, the thick section of the “P” should be toward the center of the vehicle, and the inner-most edge of the trim should be aligned with the edges of the body above and below the opening for the tail lights. See **Figure 8** on the right.
11. You are now ready to mount the Warrior Steel LED Tail Lights to your vehicle. Extra hardware is provided in case you drop something and are unable to recover it. Each tail light is attached with three carriage bolts which are passed through mounting slots in the tail light housing (Two next to the rectangular LED lights, and one on the side of the housing.) It may be useful to have a helper at this point to help hold things in place outside the vehicle while attaching hardware inside the vehicle.
- a. Begin with the two mounting locations inside the box next to the rectangular LED lights. The carriage bolts pass through the slots in the housing, and though the same holes in the FJ Cruiser body provided for the factory tail light mounting studs. Next, from the inside of the vehicle (in exact order), place a white nylon misalignment space over the threads of the carriage bolt with the angled surface toward the



Figure 8

vehicle body. Try to rotate the spacer so that the angle is aligned with the angle of the body. After the spacer is installed, place a washer on the carriage bolt and loosely start the ¼" nut on the threads. Do this for both carriage bolts in this location.

- b. For the third mounting point, after you pass the carriage bolt through the tail light housing and through the large opening in the body of the vehicle, you will need place one of the 2 ½" diameter large washers over the threads BEFORE you slide on the misalignment spacer (the large washer is needed because of the large opening in the vehicle body). After the large washer is in place, position the misalignment spacer (again with angled side toward the large washer/body), followed by the ¼" washer, and finish by loosely starting the nut as before.
- c. With the three nuts started, begin tightening the nuts while paying attention to the position of the housing on the outside of the vehicle. Tighten the nuts evenly to avoid misalignment of the housing. After you are satisfied with the position of the tail light housing and the nuts are tight, place a second nut on each carriage bolt and tighten down to lock into place.
- d. Repeat the procedure for the second side.

12. Recheck / Confirm correct function of the lights, then replace side panels and trim in the cargo area.

13. Installation complete.



**QUALITY**



**INTEGRITY**



**INNOVATION**



**SERVICE**

Learn more about custom and factory tail lights we have.