



Protecting Your Adventure Lifestyle

FJ Cruiser Sideplate Armor

Installation Instructions

WAR 3900

Please read through the instructions thoroughly before proceeding. If you are unsure of your abilities, we recommend you seek out a professional to install this product for you.

Tools required: Protective tape (painter's tape), moulding removal tool or similar pry tool, phillips screwdriver, 7/16" box end or adjustable wrench, drill, 3/16" drill bit, and a pop rivet tool.

Prepare the vehicle:

1. Remove all plastic OEM side door and rocker moulding trim. Apply a strip of protective tape on the body paint around the trim pieces to protect the paint finish during the removal and installation process.
2. The driver and passenger lower door moulding will have two nuts per side that will need to be removed in conjunction with the snap-clips. The access door lower moulding will also have one nut per side that will need to be removed along with their snap-clips. Utilizing a moulding removal tool or similar pry instrument, gently pry the top edges of the moulding pieces away from the body. They should disengage with minimal effort.
3. The front fender moulding trim pieces can also be removed with the moulding remover tool. Take care not to damage the paint finish.
4. Remove any plastic clips that remain so that the doors are stripped completely. Most clips can be turned 90° then removed straight out, but the oblong inserts will require needle nose pliers to grab onto and pull out.
5. The rocker panel moulding is only held on with clips. Pry these panels loose and remove the two rear-most clips, the wheel well insert, and the four middle oblong inserts. The vehicle is now ready to install the 3900 Warrior FJ Cruiser Sideplate Armor.

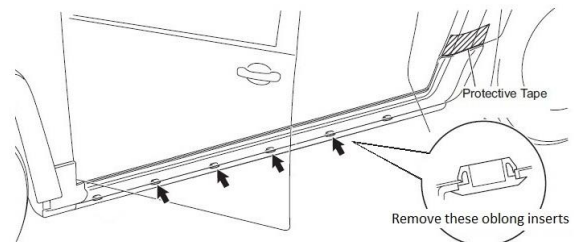
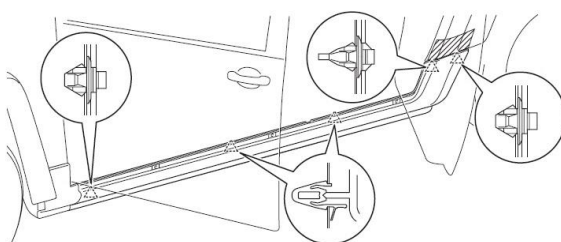
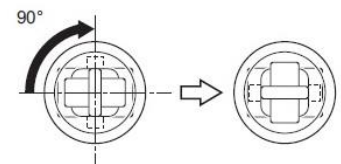
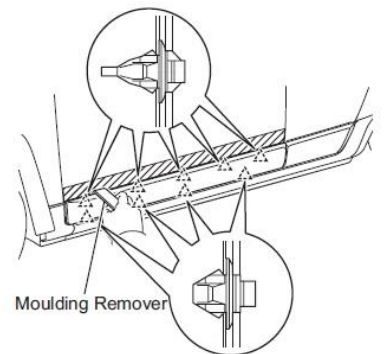
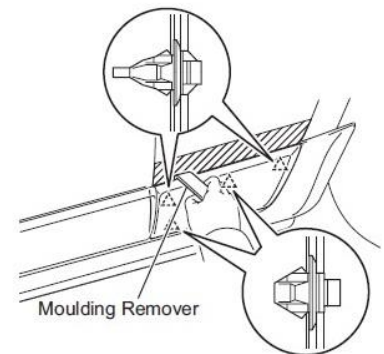

QUALITY



INTEGRITY



INNOVATION



SERVICE



Protecting Your Adventure Lifestyle

Installation:



1. Install square plastic inserts in the locations indicated in the image below. There is also an insert inside the rear wheel well as indicated by the leftmost arrow.

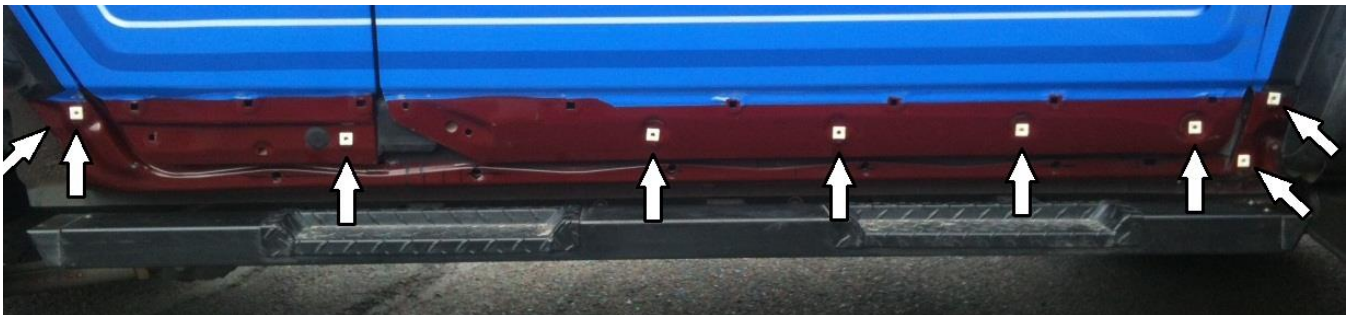

2. Begin the install with the rear access door panel. The rearward hole utilizes a 1" long screw, a rubber snubber, a flatwasher, and a nylock nut. Place the screw through the hole and capture the snubber on the inner side, then set the threads through the hole on the door. You'll need a slight amount of alignment adjustability before the final tightening, so only lightly tighten this nut at the moment. Now thread a 1/2" long screw into the forward hole and lightly tighten.

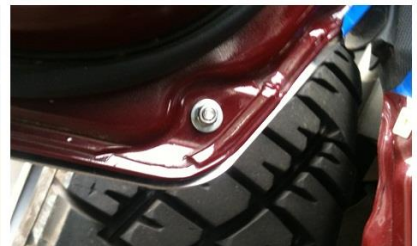

3. Next, install the lower door armor panel utilizing a 1" long screw, a flatwasher, and a nylock nut. Use the 1/2" long screws into the four square plastic inserts. Lightly tighten these screws to allow for a bit of alignment adjustability before final tightening.



Protecting Your Adventure Lifestyle

-
4. Install the front trim piece with two ½" long screws.



5. Proceed with installing the rocker armor. Line up the tabs in the rocker with the oblong holes in the FJ's body. Insert the tabs and push the rocker piece forward until tabs fully engage within the oblong holes.

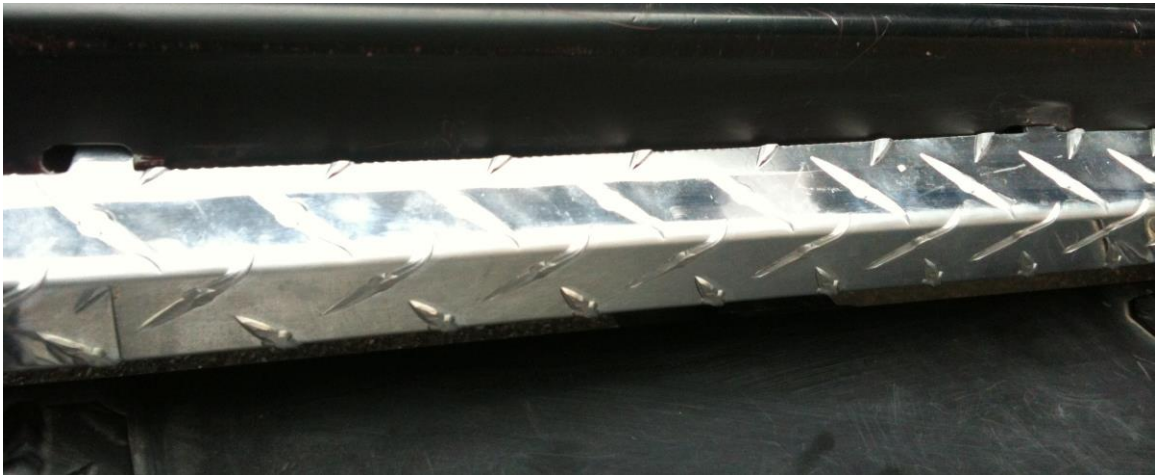

6. Once all the tabs are fully engaged, you should now be able to thread a ½" long screw into the square plastic insert at the rearward end of the rocker armor piece. Next, push in on the rearward end of the rocker armor piece towards the FJ's body until you can access the wheel well square plastic insert through the mounting tab on the rocker armor. This will slightly flex the rocker armor so that it can conform to the curve of the FJ's body.





Protecting Your Adventure Lifestyle

7. Turn your attention now to the forward end of the rocker where it relates with the front trim. There are underbody mounting tabs built into the rocker armor so that you can utilize pop rivets (included) or self tapping screws to further strengthen and line up the rocker armor. Once you have the rocker and front trim piece lined up to your satisfaction, have an assistant hold that positioning for you while you access the underside of the vehicle. Drill through the holes in the rocker mounting tabs and into the underside of the FJ's body with a 3/16" drill bit. The FJ is double-walled in these locations, so in order for the pop rivets to fully seat you'll need to drill through both layers of sheet metal. **Only drill as deep as necessary to go through both layers.** Attach with preferred method (pop rivet or self tapping screw).

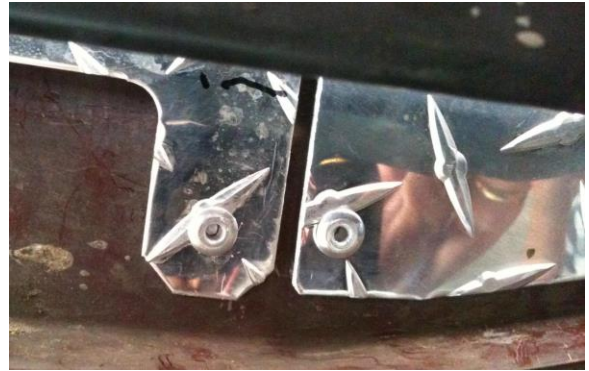

8. Perform a final visual check to confirm all the panels are aligned to your satisfaction and then go back and tighten each screw. Take care not to over-tighten as you risk stripping out the plastic inserts.

Your 3900 Warrior FJ Sideplate Armor Kit is now installed.

