



Protecting Your Adventure Lifestyle

FJ Cruiser Rear Bumper

INSTALLATION INSTRUCTIONS

3540/3550

NOTE: To fit the Warrior Products 3540 or 3550 FJ Cruiser rear bumper you must remove (i.e. cut) the plastic corner panels free from the rear bumper cover and reattach them utilizing the OEM rear corner retainers. For a much cleaner appearance, Warrior Products offers 3915 & 3920 FJ Cruiser Rear Corner Guards as armored replacements to the factory plastic corners.

1. Begin the installation by removing the OEM rear bumper cover / corners and all associated trim pieces. Remove the 5 screws along the top step of the bumper cover and 4 screws on the underside. Lastly, locate and remove the push-pins on the inner tailgate edge of the plastic corner panels. Disconnect the backup sensor wiring and/or trailer harness bracketry if equipped.

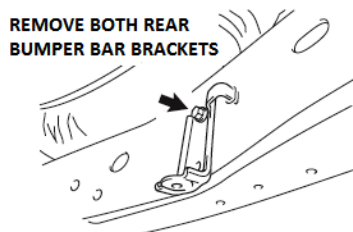
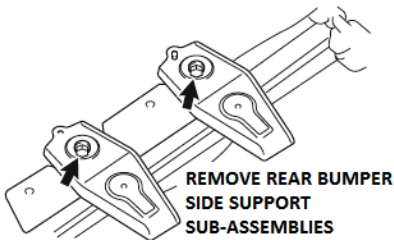
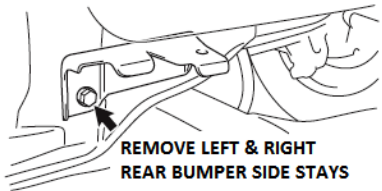
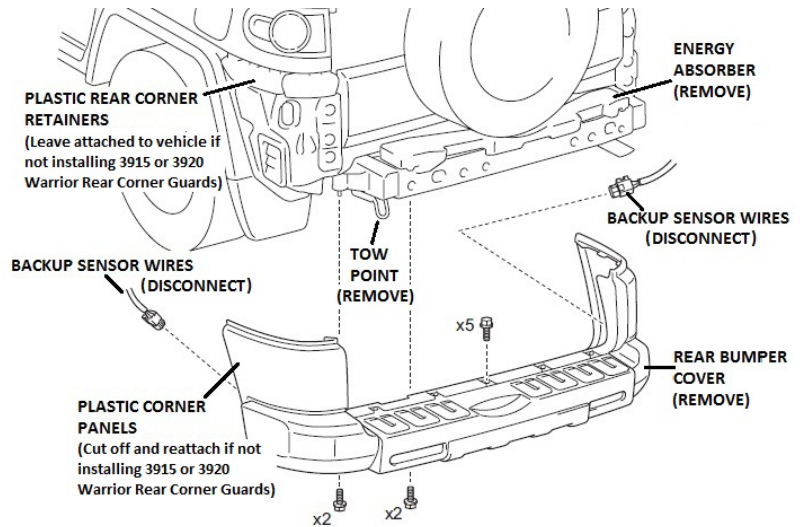

2. Begin removal of the rear bumper cover taking care not to break any mounting tabs of the plastic corner panels. Remove the rear bumper energy absorber, side stays, side support sub-assemblies, rear bumper bar brackets and the tow point.



Protecting Your Adventure Lifestyle

3. If you are reinstalling the factory plastic corner panels, you will need to cut them completely free of the rear bumper cover. This is accomplished by using a razor knife or hacksaw blade and cutting them along the hard edge where they meet the top of the factory bumper endcaps. (Fig. 1 & 2) To allow easier access to this area when cutting, remove the silver endcaps by unclipping the plastic tab on the inside of the bumper cover. **Use caution and cut away from yourself.** Clean up any burrs with a file or sandpaper and set the corners aside for reinstallation following the bumper.

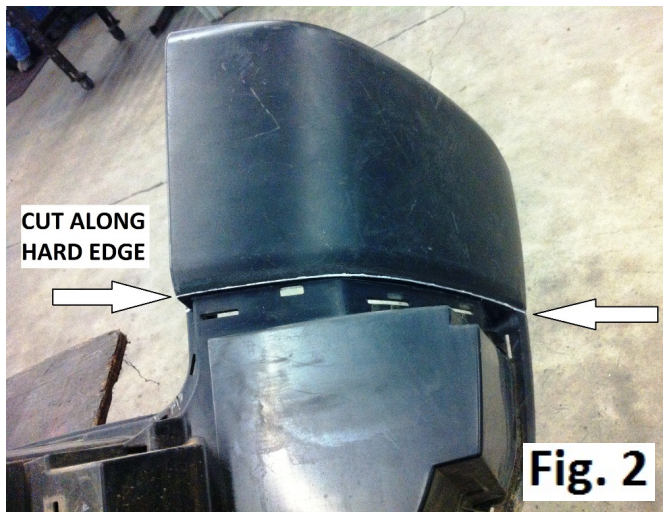
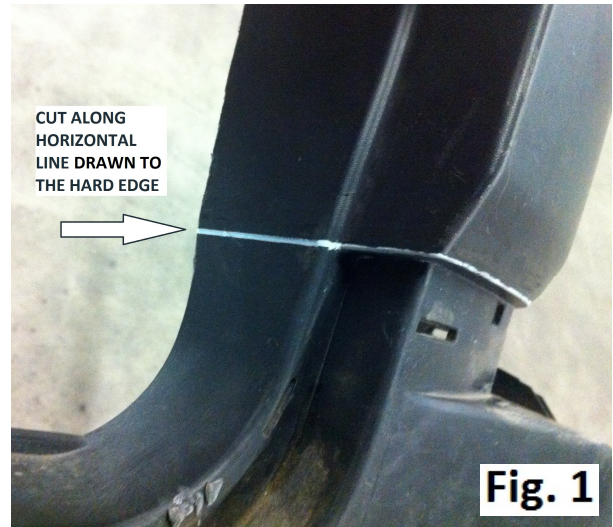

4. If your FJ is equipped with the backup sensors, remove them from the plastic bumper cover by sliding the retainers off and gently pulling the sensors out. Reinstall into the Warrior rear bumper in the same manner you removed them. (Fig. 3) **Use care as they are delicate units.** If your FJ is not equipped with the sensors, plastic plugs are provided to cover the holes.

5. Next, you will be mounting the (2) bumper frame boxes to the inside surface of the FJ's rear cross member. Each side utilizes two factory 8mm threaded holes to locate the frame boxes. Once the frame boxes are attached, use the $\frac{1}{2}$ "x1-1/2" bolts and the $\frac{5}{8}$ "x1-1/2" bolts to structurally fasten them to the cross-member. (Fig. 4) Access these washers and nuts through holes located on the front face of the rear cross member.

Plugs to the outside

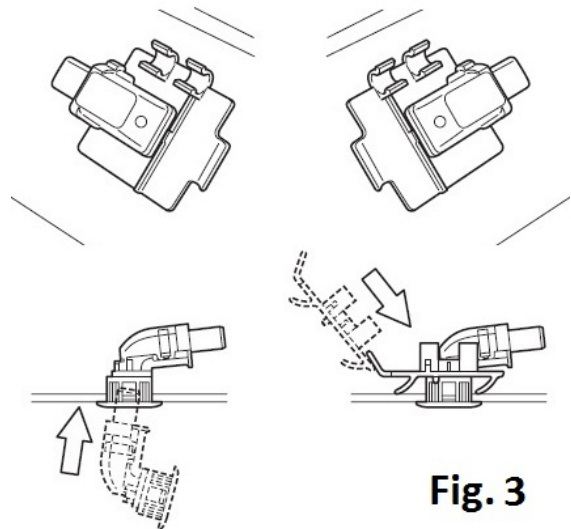

Fig. 3



Protecting Your Adventure Lifestyle

6. After both frame boxes have been located and bolted onto the rear cross-member, take the rear bumper and slide it most of the way onto the rear cross-member. If you have the backup sensors, take this moment to feed the wiring through the bumper and plug them back into the sensors. Once you are certain there is no pinching or binding of the sensor wiring, slide the bumper the rest of the way lining up the holes in the frame boxes with the slots in the bumper brackets.

7. Using the $\frac{1}{2}$ "x1-1/2" bolts, $\frac{1}{2}$ " nuts, 7/16" flatwashers and $\frac{1}{4}$ " lockwashers, loosely thread them through the bumper bracketry and frame boxes. Next, slip the two slotted frame spacers between the FJ's frame and the lower extended sections of the bumper bracketry. Use the (4) M12x40mm bolts, 7/16" flatwashers and $\frac{1}{4}$ " lockwashers and thread them most of the way into the frame. Stand back and visually align the bumper from the back and from the side of the FJ. There will be little if any side-to-side adjustability. If you are satisfied with the placement, begin tightening all the mounting bolts starting with the lower extended section of the bumper bracketry. Torque the frame bolts and frame box hardware to 80-100lbs.

8. Reinstall the plastic corner panels by snapping them back into the plastic corner retainers and using the push-pin fasteners. The backup sensor brackets may also be bent up to improve the appearance. Reinstall the towing harness bracket if equipped. Your installation of the Warrior FJ Cruiser Rear Bumper is now complete.

