



GENERAL SAFETY PRECAUTIONS



FCC and IndustryCanada(IC) Warning:

- This device complies with Part 15 of the FCC Rules. Operation is subject to the following two conditions: (1) This device may not cause harmful interference, and (2) this device must accept any interference received, including interference that may cause undesired operation.
- The term "IC:" before the radio certification number only signifies that industry Canada technical specifications were met.
- Any changes or modifications to this product not expressly approved by WARN Industries could void the user's authority to operate this product.

 WARNING		
		
MOVING PARTS ENTANGLEMENT HAZARD Failure to observe these instructions could lead to severe injury or death. To avoid injury to hands or fingers. <ul style="list-style-type: none">• Always keep hands clear of rope, hook loop, hook and fairlead opening during installation, operation, and when spooling in or out.• Always use extreme caution when handling hook and rope during spooling operations.• Always use supplied hook strap whenever spooling rope in or out, during installation and during operation.• Always keep vehicle in sight during winching operation.• Always wear heavy leather gloves when handling rope.		

 WARNING	
	
CHEMICAL AND FIRE HAZARD Failure to observe these instructions could lead to severe injury or death. <ul style="list-style-type: none">• Always remove jewelry and wear eye protection.• Never lean over battery while making connections.• Always verify area is clear of fuel lines, fuel tank, brake lines, electrical wires, etc. when drilling.• Never route electrical cables:<ul style="list-style-type: none">- Across any sharp edges.- Through or near moving parts.- Near parts that become hot.• Always insulate and protect all exposed wiring and electrical terminals.• Always install terminal boots as directed in installation instructions.	

 WARNING	
	
FALLING OR CRUSHING HAZARD Failure to observe these instructions could lead to severe injury or death. <ul style="list-style-type: none">• Never operate winch with less than 5 wraps of rope around the drum. Rope could come loose from the drum, as the rope attachment to the drum is not designed to hold a load.• Never use as an overhead hoist, or to suspend a load.• Never use to lift or move persons.	



CAUTION

MOVING PARTS ENTANGLEMENT HAZARD

Failure to observe these instructions could lead to minor or moderate injury.

General Safety:

- **Always** Know Your Winch. Take time to fully read the Installation and Operations Guide, and Basic Guide to Winching Techniques, in order to understand your winch and its operation.
- **Never** operate this winch if you are under 16 years of age.
- **Never** operate this winch when under the influence of drugs, alcohol or medication.
- **Never** exceed winch or rope capacity listed on product data sheet. Double line using a snatch block to reduce winch load.
- **Never** use winch or rope for towing.

Installation Safety:

- **Always** choose a mounting location that is sufficiently strong to withstand the maximum pulling capacity of your winch.
- **Always** use factory approved mounting hardware, components, and accessories.
- **Always** use grade 5 or better hardware.
- **Never** weld mounting bolts.
- **Always** use care when using longer bolts than those supplied from factory. Bolts that are too long can damage the base and/or prevent the winch from being mounted securely.
- **Always** mount the winch and attach the hook to the rope's end loop before connecting the electrical wiring.
- **Always** position fairlead with WARNING label on top.
- **Always** spool the rope onto the drum in the direction specified by the winch warning label on the winch and/or documentation. This is required for the automatic brake to function properly.
- **Always** prestretch rope and respool under load before use. Tightly wound rope reduces chances of "binding", which can damage the rope.



CAUTION

MOVING PARTS ENTANGLEMENT HAZARD

Failure to observe these instructions could lead to minor or moderate injury.

Winching Safety:

- **Always** inspect rope, hook, and slings before operating winch. Damaged components must be replaced before operation. Protect parts from damage.
- **Never** leave wired remote control plugged into winch when free spooling, rigging, or when the winch is not being used.
- **Never** hook rope back onto itself. This damages the rope.
- **Always** use a choker chain, choker rope, or tree trunk protector on the anchor.
- **Always** remove any element or obstacle that may interfere with safe operation of the winch.
- **Always** take time to use appropriate rigging techniques for a winch pull.
- **Always** be certain the anchor you select will withstand the load and the strap or chain will not slip.
- **Never** engage or disengage clutch if winch is under load, rope is in tension or drum is moving.
- **Never** touch rope or hook while in tension or under load.
- **Never** touch rope or hook while someone else is at the control switch or during winching operation.
- **Always** stand clear of rope and load and keep others away while winching.
- **Always** be aware of stability of vehicle and load during winching. Alert all bystanders of any unstable condition.
- **Never** use a winch to secure a load.



CAUTION

MOVING PARTS ENTANGLEMENT HAZARD

Failure to observe these instructions could lead to minor or moderate injury.

Winching Safety:

- **Always** keep wired remote control lead clear of the drum, rope, and rigging. Inspect for cracks, pinches, frayed wires or loose connections. Replace remote control if damaged.
- **Always** pass wired remote control through a window to avoid pinching lead in door, when using remote inside a vehicle.
- **Never** leave remote control where it can be activated during free spooling, rigging, or when the winch is not being used.



CAUTION



CUT AND BURN HAZARD

Failure to observe these instructions could lead to minor or moderate injury.

To avoid injury to hands or fingers:

- **Always** wear heavy leather gloves when handling a rope.
- **Never** let rope slip through your hands.
- **Always** be aware of possible hot surface at winch motor, drum or rope during or after winch use.



CAUTION

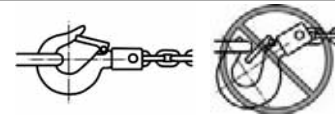

MOVING PARTS ENTANGLEMENT HAZARD

Failure to observe these instructions could lead to minor or moderate injury.

- **Always** use a hook with a latch.
- **Always** ensure hook latch is closed and not supporting load.
- **Never** apply load to hook tip or latch. Apply load only to the center of hook.
- **Never** use a hook whose throat opening has increased, or whose tip is bent or twisted.

NOTICE

AVOID WINCH AND EQUIPMENT DAMAGE

- **Always** avoid side pulls which can pile up rope at one end of the drum. This can damage rope or winch.
- **Always** ensure the clutch is fully engaged or disengaged.
- **Never** use winch to tow other vehicles or objects. Shock loads can momentarily exceed capacity of rope and winch.
- **Always** avoid "powering out" rope for extended distances. This causes excess heat and wear on the winch motor and brake.
- **Always** use care to not damage the vehicle frame when anchoring to a vehicle during a winching operation.
- **Never** "jog" rope under load. Shock loads can momentarily exceed capacity of rope and winch.
- **Never** use winch to secure a load during transport.
- **Never** submerge winch in water.
- **Always** store the remote control in a protected, clean, dry area.
- **Always** double line or pick distant anchor point when rigging. This maximizes pulling power and avoids overloading the winch.
- **Never** mount receiver near parts that get hot.
- **Never** mount receiver next to battery.

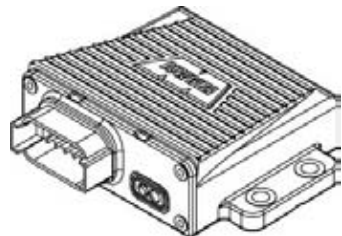
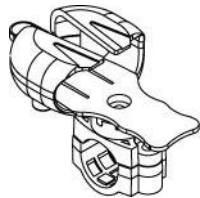
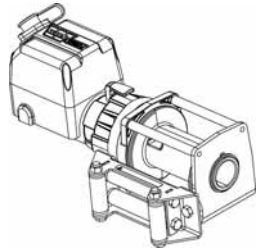
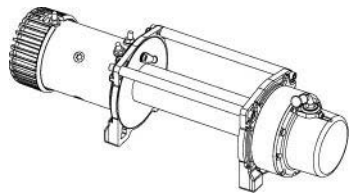

OVERVIEW

The WARN Wireless Control gives you the ability to operate the winch using a wireless hand held remote. The wireless control system integrates with a standard winch control pack so that the operator may use either the wired or wireless controls at any time.

To use the wireless system, the operator first activates the system by pressing and holding both buttons on the wireless remote for 3 seconds. This transfers control of the winch to the wireless control system. The GREEN indicator light on the handheld remote glows when the system is active and ready to use. Deactivate the system by pressing both buttons on the wireless transmitter simultaneously and holding for 3 seconds until GREEN light turns off.

After 2 minutes of idle time, the wireless system de-activates.

SAFETY

When installing your winch and winch control system, read and follow all mounting and safety instructions. Always use caution when working with electricity and remember to verify that no exposed electrical connections exist before energizing your winch circuit.

SPECIFICATIONS

Part numbers for complete system:

PN 76080 - Wireless control system (Truck)

PN 79080 - Wireless control system (Utility)

Transmission range:

Up to 90 ft. (27m)

Receiver Operating voltage:

8 to 24 VDC

Receiver Fuse type and current rating:

ATC 7.5 amp

Batteries for hand held remote:

two alkaline, 12 volt, type 23

WIRELESS CONTROL KIT INCLUDES:

- Wireless Receiver (1)
- Wireless Transmitter (1)
- Wiring Harness (1)
- Holster Assembly (1)
- Hardware Kit (1)

STEP 1: MOUNT ALL WINCH COMPONENTS

First install the winch and control pack. Then install the wireless control system.

Location for these components may differ from the illustration depending on make and model of the vehicle. Read and understand the instructions to choose the appropriate mounting locations.

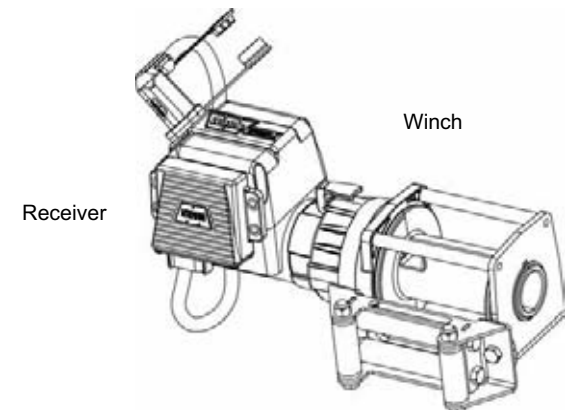
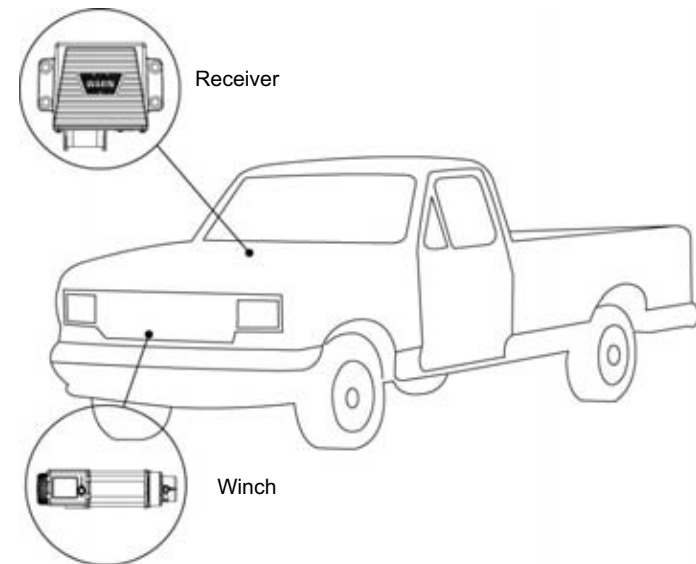

⚠ WARNING

TO PREVENT SERIOUS INJURY OR DEATH FROM EXPLOSION:

- Do not drill into gas tank.
- Verify the area is clear behind the mounting location before drilling.

STEP 2: MOUNT THE RECEIVER

The receiver must be correctly installed to work properly. The receiver should be mounted in a location that is as clean and dry as possible while also allowing access to the programming button. The mounting location must also provide clearance for the wire harness to attach to the receiver.

Best locations for the receiver will vary depending on the vehicle. Typical locations include: under dash, on inner fender inside engine compartment. Avoid mounting receiver near battery or exhaust manifold. Maximum operating temperature is 220 F° (104°C).

Mounting Steps:

1. Determine the mounting location.
2. Mount on a flat surface, mark and drill a minimum of two (2) mounting holes, one on each side of the receiver.
3. Loosely attach the receiver using 1/4-inch or M6 bolts and locknuts.
4. Tighten fasteners.

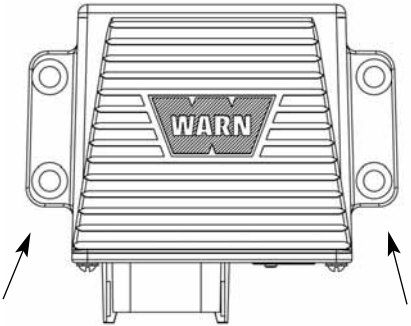
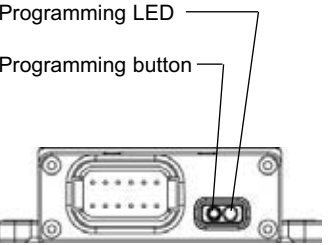
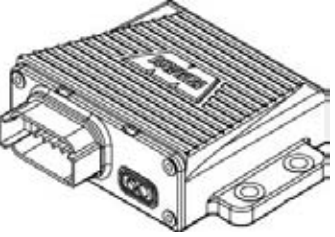

Minimum of one fastener on each side

STEP 3: ROUTE THE HARNESS

Routing Steps:

1. Plan a route for the wire harness between the receiver and the winch control pack.
2. Route harness.

⚠ WARNING

TO AVOID SERIOUS INJURY OR DEATH FROM ELECTRICAL FIRE:

- **Never** route electrical cables:
 - Across any sharp edges.
 - Through or near moving parts.
 - Near parts that become hot.
- **Always** insulate and protect all exposed wiring and electrical terminals.

⚠ WARNING

TO AVOID SERIOUS INJURY OR DEATH FROM ELECTRICAL FIRE:

- **Never** route electrical cables:
 - Across any sharp edges.
 - Through or near moving parts.
 - Near parts that become hot.
- **Always** insulate and protect all exposed wiring and electrical terminals.

STEP 4: CONNECT THE WIRING

Note: Refer to Figure 1.

1. Connect the wire harness to the receiver.
2. Connect the 90 degree plug on the wire harness into the winch control pack.
3. Use tie wraps to secure the wire harness.

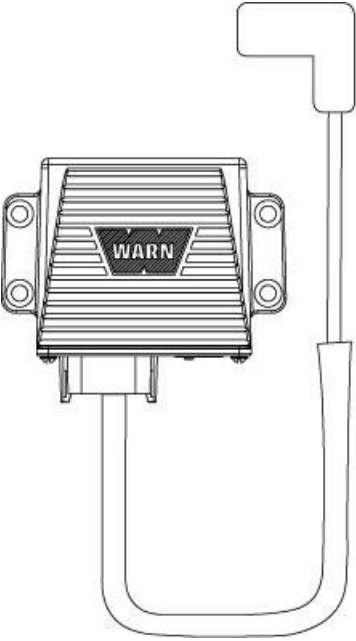
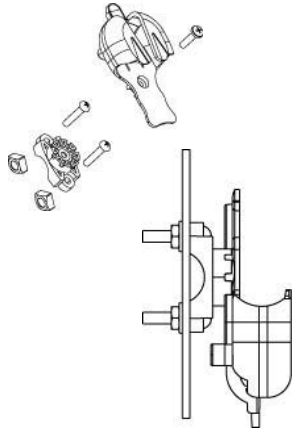

Figure 1: Wiring Installation Diagram

⚠ WARNING

TO AVOID SERIOUS INJURY OR DEATH:

- **Always** use caution when moving or repositioning any vehicle controls so as to not compromise the safe operation of the winch or vehicle. Select a mounting position that will provide clearance for all vehicle controls.
- **Never** attempt to bypass receiver by connecting switches directly to contactor.



⚠ CAUTION

ALWAYS KNOW YOUR WINCH:

Take time to fully read and understand the included Installation and Operations Guide, and Basic Guide to Winching Techniques, in order to understand your winch and the winching operation.

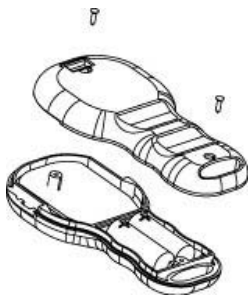

STEP 5: MOUNT THE HOLSTER

- Find a suitable location to mount the holster. The holster can be mounted to a shaft or a flat surface.
- The holster clamp must be mounted before assembly.
- Do not mount over any hoses, cables, or wiring.
- Assemble the holster as shown. Holster may be oriented in any one of eight positions.

STEP 6: SYSTEM CHECK

1. Insure that wiring to all components is correct and all loose wires are securely tie wrapped.
2. Insure that there are no exposed terminals or wiring. Cover any bare terminal with terminal boots, heat shrink tubing or electrical tape.
3. Check winch for proper operation using a standard remote. The wire rope should spool in and out in the direction indicated on the switch. If winch functions correctly, proceed to the next step. Otherwise troubleshoot.
4. Plug in the wire harness to the control pack remote receptacle.
5. Press and hold both buttons on the wireless handheld remote until the GREEN indicator light illuminates. The wireless system is now active and ready to use.
6. By pressing the buttons on the remote, verify that the winch powers IN and powers OUT properly.

REPLACING BATTERIES

If the indicator light on the handheld remote flashes RED during winching, the batteries are low and should be replaced.

1. Remove the two screws from the handheld remote.
2. Separate the top and bottom sections of the remote using a coin or screw driver.
3. Remove the old batteries and dispose in accordance with local environmental regulations.
4. Insert new alkaline batteries as shown with the positive terminals facing the switches. Do not mix old and new batteries.
5. Join the top and bottom sections making sure that they snap together and rubber seal remains intact.
6. Secure with the two screws.

This WARN Wireless Control System has been designed to minimize interference from other sources of radio.

⚠ CAUTION

TO AVOID MINOR OR MODERATE INJURY:

- **Always** be aware that obstacles and other radio transmission sources may affect performance.
- **Always** insure the matching WARN transmitter is closer to its receiver than other transmitters in use during winching.

⚠ CAUTION

TO AVOID MINOR OR MODERATE INJURY:

- **Always** use wired remote when intermittently "jogging" winch.

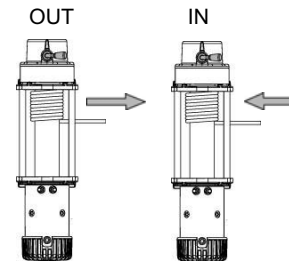

OPERATION

Turn On Sequence:

1. Activate the system by pressing both buttons on the wireless transmitter simultaneously and holding for 3 seconds until GREEN light illuminates.
2. The winch system is now operational.
3. Press the power IN or power OUT button as needed.

Turn Off Sequence:

1. Deactivate the system by pressing both buttons on wireless transmitter simultaneously and holding for 3 seconds until GREEN light turns off.

LED Indicator Light

Steady GREEN - system active and ready to use
Steady RED - winch powering in or out
Flashing RED during winching - battery low

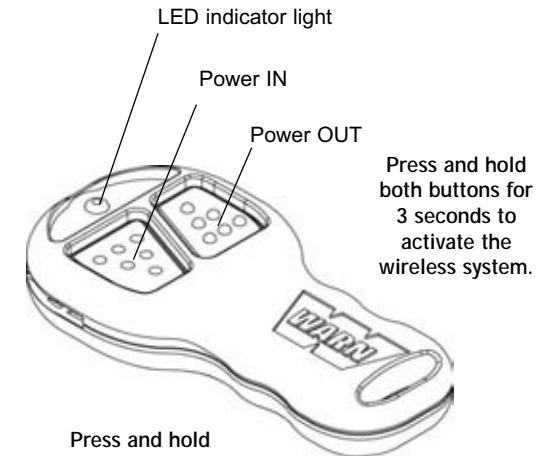

Press and hold both buttons for 3 seconds to deactivate the wireless system.

TROUBLESHOOTING

If the winch does not power in or out when remote buttons are pushed:

1. Check that the wireless system has been activated (GREEN LED on remote is ON).
2. Check all electrical connections. Verify that connections follow the wiring diagram and instructions.

PROGRAMMING THE RECEIVER

The hand held remote (transmitter) is programmed from the factory to communicate with your specific receiver. Under normal circumstances programming will not be necessary. However, any replacement remote must be programmed to communicate with your receiver. Use the following procedure:

1. Insure the system is properly installed and connected.
2. Activate the new remote by pressing and holding both buttons on the wireless handheld remote until the GREEN LED illuminates.
3. Press and hold the receiver programming button for at least five (5) seconds until the RED LED on the receiver illuminates and stays on.
4. Release the programming button.
5. Press the power OUT button on the remote for at least one (1) second until the RED LED on the receiver turns off. Programming is now complete.

NOTE: Only one remote can be programmed for each receiver.

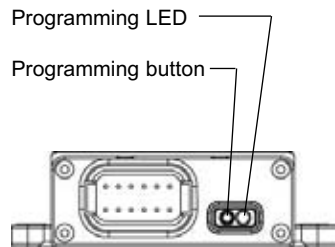

! WARNING

TO AVOID SERIOUS INJURY OR DEATH:

- **Never** attempt to service components inside transmitter or receiver.
- **Always** consult an authorized WARN service center for service or warranty.

WARRANTY

Please refer to the warranty sheet enclosed with your winch for details.

REPLACEMENT PART NUMBERS

Ordering information: Parts may be obtained through your local dealer or distributor.

Part Number	Description
PN 77825	Receiver Module
PN 74524	Holster
PN 76087	Harness (Truck)
PN 79087	Harness (Utility)
PN 74604	Hardware Kit
PN 74520	Replacement transmitter (Remote)