



# ZEON-12 WINCH (24V)

**Part Number:** 90666

**Rated Line Pull:** 12,000 lbs. (5440 kgs)

**Motor:** 24V DC, Series Wound

**Controls:** Remote switch, 12' (3.7m) Lead

**Gear train:** 3-Stage Planetary

**Gear Ratio:** 216:1

**Clutch (Freespool):** Rotating Ring Gear

**Brake:** Automatic Direct Drive Cone

**Drum diameter/length:** 3.15"/9.3" (8.0cm/23.6cm)

**Kit Shipping Weight:** 82.7 lbs (37.5 kgs)

**Battery:** 400CCA Minimum for winching

**Duty Cycle:** Intermittent

**Battery leads:** 25mm<sup>2</sup>, 72" (1.83m)

**Finish:** Black Powder Coat

**Warranty:** Limited Lifetime

**Mounting Bolt Pattern:** 10.0" x 4.5" (254mm x 114.3mm)

**Winch Dimensions:** 24.25 L x 7.14" D x 10.52" H (615.9mm L x 181.6mm D x 267.1mmH)

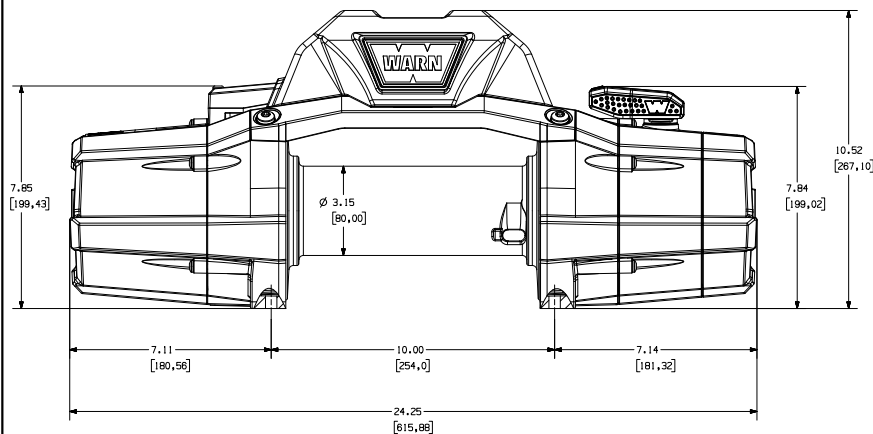

## SERVICE INSTRUCTIONS

Should you encounter a problem during installation or operation of your winch, please follow these steps toward resolving the problem:

1. Refer to your operator's guide and installation instructions. It has illustrations and detailed information on the installation and safe and proper operation of your winch. It also includes a replacement parts list and assembly diagrams. If you are unable to resolve the problem, then go to step 2.
2. Contact your dealer where you purchased your winch. If, after discussing the problem with their parts and service staff, you are still unable to resolve the problem then go to step 3.
3. Call an Authorized WARN Service center from the list provided on the back of the warranty sheet included with the product. When calling, please have the following information available: winch model number and purchase date, make, model and year of vehicle.

## SERVICE/UPGRADE KITS

	PN#	ITEM	QTY	DESCRIPTION
KIT 1	89304	8	1	S/P, TRANSMISSION 216, ASSY
		9	1	ROTATING RING GEAR
		(2)	1	RETAINING RING
		(3)	1	S/P, END HOUSING, ASSEMBLY
		(4)	1	S/P, END CAP
		10	1	S/P, DRUM SUPPORT, GEARTRAIN
		11	1	SUN GEAR, 12T
		21	1	CARRIER ASSY, STAGE 1
		21	1	DRIVE SHAFT
		12	1	CARRIER ASSY, STAGE 2
		13	1	WASHER, THRUST
		14	1	CARRIER ASSY, STAGE 3
		15	1	RING GEAR, 75T
		20	1	DRIVE SPLINE
42	1	DRUM DRIVER		
KIT 2	89237	6	1	S/P, END HOUSING, ASSEMBLY
		5	1	CLUTCH LEVER
		7	1	SEAL, O-RING
		7	1	DETENT, M5 SCREW
		8	1	ROTATING RING GEAR
		9	1	RETAINING RING
		2	1	GASKET, END CAP
		6	1	GEARTRAIN GASKET
		3	10	TORX, PAN HEAD, M5-0.8 x 25

KIT 3	89238	1	1	S/P, END CAP
				END CAP
		2	1	GASKET, END CAP
		3	5	TORX, PAN HEAD, M5-0.8 x 25
KIT 4	89239		1	S/P, DRUM SUPPORT, GEARTRAIN
		17	1	DRUM SUPPORT, GEARTRAIN
		18	1	DRUM BUSHING
		19	1	DRUM SEAL
		16	1	GEARTRAIN GASKET
		3	5	TORX, PAN HEAD, M5-0.8 x 25
KIT 5	89240		1	S/P, BRAKE ASSY
		22	1	BRAKE ASSY
		21	1	DRIVE SHAFT
		23	1	CASTING,MOTOR COUPLER
		24	1	DRUM
KIT 6	91065		1	S/P, MOTOR 10 TURN
		27	1	MOTOR 10 TURN
		25	1	DRUM BUSHING, MOTOR
		19	1	DRUM SEAL
KIT 7	91066		1	S/P, CONTROL PACK
		30	1	S/P 24VDC CONTACTOR PLATE ASSEMBLY
		28	1	S/P CONTROL PACK COVER ASSEMBLY
		26	1	GROUND CABLE 25mm <sup>2</sup>
		37	1	POWER CABLE 25mm <sup>2</sup>
KIT 8	89627		1	S/P BUS BARS
		33	1	BUS BARS
		35	1	TOP, BUSS BAR COVER
		34	1	BASE, BUSS BAR COVER
		36	1	TORX, PAN HEAD, M6-1.0 x 25
INDIVIDUAL ITEMS				
	13874	10	1	SUN GEAR, 12T
	88636	11	1	CARRIER ASSY, STAGE 1
	88251	21	1	DRIVE SHAFT
	91047	12	1	CARRIER ASSY, STAGE 2
	88543	13	1	WASHER, THRUST
	88521	14	1	CARRIER ASSY, STAGE 3
	88252	15	1	RING GEAR, 75T
	90281	20	1	DRIVE SPLINE
	13824	42	1	DRUM DRIVER
	90053	41	1	ANCHOR PUCK
	89242	32	1	S/P, TIE PLATE
	89214	39	1	S/P, FAIRLEAD, ROLLER
	83085	29	1	S/P 24VDC CONTACTOR
	90274	30	1	S/P 24VDC CONTACTOR PLATE ASSEMBLY
	89244	28	1	S/P CONTROL PACK COVER ASSEMBLY
	83665	40	1	S/P REMOTE CONTROL
	87452	26	1	GROUND CABLE 25mm <sup>2</sup>
	88692	37	1	POWER CABLE 25mm <sup>2</sup>
	88371	3	10	TORX, PAN HEAD, M5-0.8 x 25
	88682	26	1	TORX, PAN HEAD, M6-1.0 x 25
	83475	31	4	TORX, PAN HEAD, M8-1.25 x 25