



# ZEON-8 MULTI-MOUNT WINCH

**Part Number:** 90260

**Rated Line Pull:** 8000 lbs. (3629 kgs)

**Motor:** 12V DC, Series Wound

**Controls:** Remote switch, 12' (3.7m) Lead

**Gear train:** 3-Stage Planetary

**Gear Ratio:** 162:1

**Clutch (Freespool):** Rotating Ring Gear

**Brake:** Automatic Direct Drive Cone

**Drum diameter/length:** 3.15"/9.3" (8.0 cm/23.6 cm)

**Kit Shipping Weight:** 118 lbs (53.5 kgs)

**Rope:** Wire rope, Ø 5/16" x 100' (Ø 8mm x 30.5m)

**Fairlead:** Hawse

**Recommended Battery:** 650CCA Minimum for winching

**Duty Cycle:** Intermittent

**Battery leads:** 2 GA, 90" (2.2m)

**Finish:** Black Powder Coat

**Warranty:** Limited Lifetime

**Mounting Bolt Pattern:** 10.0" x 4.5" (254mm x 114.3mm)

**Winch Dimensions:** 24.25 L x 7.14" D x 10.52" H (615.9mm L x 181.6mm D x 267.1mmH)

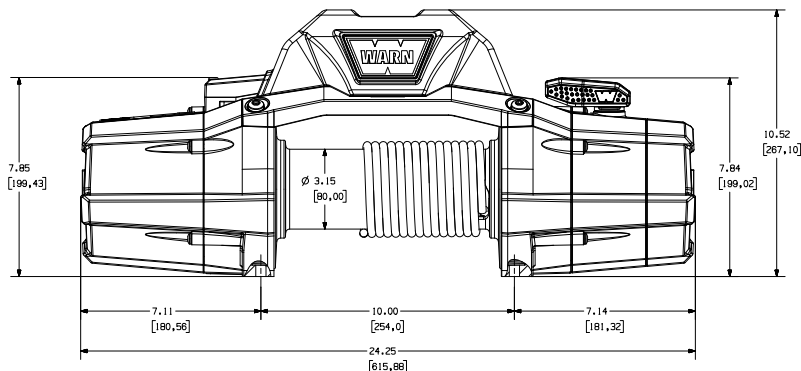

## SERVICE INSTRUCTIONS

Should you encounter a problem during installation or operation of your winch, please follow these steps toward resolving the problem:

1. Refer to your operator's guide and installation instructions. It has illustrations and detailed information on the installation and safe and proper operation of your winch. It also includes a replacement parts list and assembly diagrams. If you are unable to resolve the problem, then go to step 2.
2. Contact your dealer where you purchased your winch. If, after discussing the problem with their parts and service staff, you are still unable to resolve the problem then go to step 3.
3. Call an Authorized WARN Service center from the list provided on the back of the warranty sheet included with the product. When calling, please have the following information available: winch model number and purchase date, make, model and year of vehicle.

## SERVICE/UPGRADE KITS

	PN#	ITEM	QTY	DESCRIPTION
KIT 1	89302	8	1	S/P, TRANSMISSION 162, ASSY
		9	1	ROTATING RING GEAR
		(2)	1	RETAINING RING
		(3)	1	S/P, END HOUSING, ASSEMBLY
		(4)	1	S/P, END CAP
		10	1	S/P, DRUM SUPPORT, GEARTRAIN
		11	1	SUN GEAR, 12T
		21	1	CARRIER ASSY, STAGE 1
		12	1	DRIVE SHAFT
		13	1	CARRIER ASSY, STAGE 2
		14	1	WASHER, THRUST
		15	1	CARRIER ASSY, STAGE 3
		20	1	RING GEAR, 75T
		43	1	DRIVE SPLINE DRUM DRIVER
KIT 2	89237	6	1	S/P, END HOUSING, ASSEMBLY
		5	1	CLUTCH LEVER
		7	1	SEAL, O-RING
		8	1	DETENT, M5 SCREW
		9	1	ROTATING RING GEAR
		2	1	RETAINING RING
		6	1	GASKET, END CAP
		3	10	GEARTRAIN GASKET TORX, PAN HEAD, M5-0.8 x 25

KIT 3	89238			S/P, END CAP	
			1	END CAP	
		1	1	GASKET, END CAP	
		2	1	TORX, PAN HEAD, M5-0.8 x 25	
		3	5		
KIT 4	89239			S/P, DRUM SUPPORT, GEARTRAIN	
			17	1	DRUM SUPPORT, GEARTRAIN
			18	1	DRUM BUSHING
			19	1	DRUM SEAL
			16	1	GEARTRAIN GASKET
			3	5	TORX, PAN HEAD, M5-0.8 x 25
KIT 5	89240			S/P, BRAKE ASSY	
			22	1	BRAKE ASSY
			21	1	DRIVE SHAFT
			23	1	CASTING,MOTOR COUPLER
		24	1	DRUM	
KIT 6	89931			S/P, MOTOR 3 TURN	
			27	1	MOTOR 3 TURN
			25	1	DRUM BUSHING, MOTOR
		19	1	DRUM SEAL	
KIT 7	90364			S/P, COFFRET DE COMMANDE, 2GA	
			30	1	S/P PLAQUE CONTACTEUR 12 V CC
			28	1	S/P, COUVERCLE COFFRET DE COMMANDE
			26	1	CÂBLE 2GA ALIMENTATION, 2,2m
		37	1	CÂBLE 2GA ALIMENTATION, 71cm	
KIT 8	89627			S/P BUS BARS	
			33	1	BUS BARS
			35	1	TOP, BUSS BAR COVER
			34	1	BASE, BUSS BAR COVER
			36	1	TORX, PAN HEAD, M6-1.0 x 25
<b>INDIVIDUAL ITEMS</b>					
	13874	10	1	SUN GEAR, 12T	
	88690	11	1	CARRIER ASSY, STAGE 1	
	88251	21	1	DRIVE SHAFT	
	88508	12	1	CARRIER ASSY, STAGE 2	
	88543	13	1	WASHER, THRUST	
	88521	14	1	CARRIER ASSY, STAGE 3	
	88252	15	1	RING GEAR, 75T	
	90281	20	1	DRIVE SPLINE	
	13824	43	1	DRUM DRIVER	
	90052	41	1	ANCHOR PUCK	
	89242	32	1	S/P, TIE PLATE	
	89212	38	1	S/P, WIRE ROPE, 5/16x100'	
	84308	39	1	S/P, FAIRLEAD, HAWSE	
	81400	29	1	S/P 12VDC CONTACTOR	
	89626	30	1	S/P 12VDC CONTACTOR PLATE ASSEMBLY	
	89244	28	1	S/P CONTROL PACK COVER ASSEMBLY	
	83665	40	1	S/P REMOTE CONTROL	
	26405	26	1	POWER CABLE 2GA, 2.2m	
	36080	37	1	POWER CABLE 2GA, 71cm	
	88371	3	10	TORX, PAN HEAD, M5-0.8 x 25	
	88682	26	1	TORX, PAN HEAD, M6-1.0 x 25	
	83475	31	4	TORX, PAN HEAD, M8-1.25 x 25	
	90343	42	1	BRACKET, MULTI-MOUNT	