





SERVICE GUIDE
For
WARN PULLZALL
24Vdc P/N 885005 &
885006

- **REPAIR / REPLACEMENT INSTRUCTIONS**
- **TROUBLE SHOOTING GUIDE**



WARNING

This guide identifies potential hazards and has important safety messages that help you and others avoid personal injury or death. **WARNING** and **CAUTION** are signal words that identify the level of hazard. These signal words mean:

 **WARNING** signals a hazard that may cause serious injury or death, if you do not follow recommendations.  **CAUTION** signals a hazard that may cause minor to moderate injury, if you do not follow recommendations.

This guide uses  **NOTICE** to call attention to important mechanical information, and

Note: to emphasize general information worthy of special attention.

Notice

- This guide has been provided for use by WARN Authorized Service Centers. Any other use is prohibited.

Caution

Moving parts entanglement hazard

Failure to observe these instructions could lead to minor or moderate injury

- **Always** take time to read fully and understand the instructions.
- **Never** operate this product if you are under 16 years of age.
- **Never** operate this product under the influence of drugs, alcohol or medications.

Read instructions thoroughly

Notice

Equipment damage

- **Always** refer to the wiring diagram for all wiring schematics and specific details on how to wire this **WARN** product.

Read instructions thoroughly.

1. GENERAL DESCRIPTION

The PullzAll is a powerful, lightweight, easy-to-use handheld electric tool with the ability to lift or pull up to 1,000 lbs. A strong Motor and Variable Speed Control allow you to move heavy items into place smoothly and precisely. These features equate to saving both time and money.

The PullzAll helps in getting the job done easier, faster and with less manual labor than a come-a-long or chain fall, making you more productive. The PullzAll is for the tradesperson, farmer/rancher, or anyone that needs to lift or pull up to 1,000 lbs. This makes PullzAll ideal for construction, pipe fitting, iron work, equipment and plant maintenance, farm and ranch use, auto shops, garages, machine shops, home improvement, hunting, camping and more.

Cordless PullzAll 24VDC Specifications:

1. Part number 885005 (Domestic US), 885006 (International).
 2. Light weight and portable.
 3. Powerful 24 Volt rechargeable NiMH Battery pack (with charger and spare Battery)
 4. 1,000 lbs. lifting/pulling capacity.
 5. 15' of 7/32" diameter Wire Rope.
 6. Variable Speed Control for precision load placement.
 7. Convenient forward/reverse Switch.
 8. Electronic Load Limiter with LED Indicator for operator feedback.
-

Variable Speed Trigger Switch

Convenient Forward / Reverse Switch

Electronic Load Limiter with LED Indicator for Operator Feedback

1,000lbs lifting/pulling

Integrated Swiveling Anchor Hook

On/Off Switch

Powerful 24volt Recharge NiMH Battery Pack

15' of Ø7/32" Wire Rope

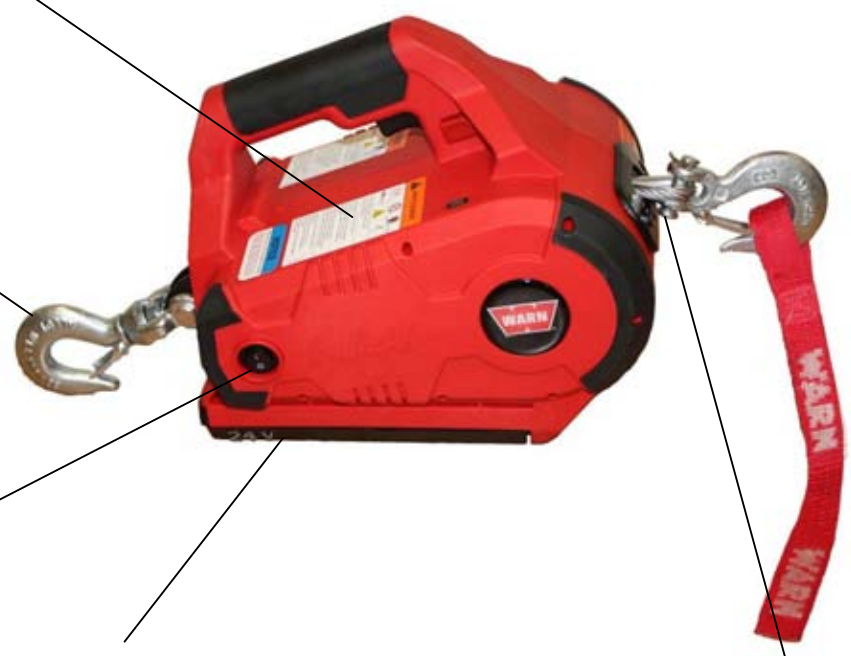

2.1 SUGGESTED TOOLS

1. Hammer
 2. Snap ring plier
 3. Allen key set
 4. Screw driver
 5. Cutting plier
 6. Pin remover (Punch)
 7. Insulation tape
 8. Gloves
-

2.2 BATTERY

2.2.1 REMOVAL OF BATTERY

Removing the Battery Pack

- Verify the power switch is in the OFF position.
- Push down the release button back of the Battery and slide the Battery away from the PullzAll body.
- Remove the Battery when not in use. Permanent damage may occur if the unit is allowed to self-discharge in ON position



1. Hold the PullzAll in the position shown in figure, push down the release button at back of the Battery and slide the Battery away from the PullzAll body and pull Battery as shown direction



2. Slide away complete Battery from the PullzAll body



2.2.2 ASSEMBLY OF BATTERY

1. Hold the PullzAll in the position as shown in figure. Slide the Battery pack into the body as shown direction



2. Slide Battery pack completely into the PullzAll body; make sure that the latch is fully engaged.



The PullzAll Battery uses NiMH technology. Generally, they can be disposed of in a municipal waste stream. However, check your local ordinances for disposal or recycling regulations.



2.2.3 INSPECTION OF BATTERY

- Inspect the Battery is not cracked or damaged.
- Inspect whether the release button in hold position or not.

Safety Rules & Guidelines:

- Battery tools are always in an operative condition. Be aware of the possible hazards. Always remove the Battery when the PullzAll™ is not in use.
- Battery leakage may occur under extreme usage or temperature conditions. If liquid comes in contact with skin, wash quickly with soap and water, then with lemon juice or vinegar. If liquid gets into your eyes, flush them with water for a minimum of 10 minutes and seek medical attention.
- Do not run the PullzAll™ while carrying it at your side.

Battery Care:

When Batteries are not in tool, keep them away from the metal objects. For example: To protect the terminals from shorting. **DONOT** place

Batteries in a toolbox or pocket with nails, screws, keys, etc. Fire or injury may result.

DO NOT PUT BATTERY INTO FIRE OR EXPOSURE TO HIGH HEAT. They may explode.

Battery Disposal:

⚠WARNING

Do not attempt to disassemble the Battery or remove any component projecting from the Battery terminals. Fire or injury may result. Prior to disposal protect exposed terminal with heavy insulating tape to prevent shorting.

2.3 HOUSING

Before opening the Housing follow the below instructions:

Power Switch:

Always turn Power switch off. Permanent battery damage may occur if the unit is allowed to self discharge in the ON position.

Removing the Battery Pack:

- Verify the power Switch is in the OFF position.

Push down the release Button back of the Battery and slide the Battery away from the PullzAll body as shown.



2.3.1 REMOVAL OF HOUSING

1. Remove 6 screws (#6 x .75) from Handle



2. Remove 6 screws (#8 X 1.25) from the main body of the Housing.



3. Keep the assemblies on the work bench facing the cover in the direction shown in the figure.



4. Remove the Plastic Housing (left hand) from the assembly as shown in the figure.



5. Remove wiring connections of the Motor assembly from Trigger Switch (red and black wires) as shown in figure.



6. Remove the Main Chassis from the Plastic Housing.



7. Keep the Main Chassis on the work bench.



2.3.2 ASSEMBLY OF HOUSING

1. Keep the right hand Housing on the work bench



2. Install the Chassis assembly into the right hand Housing as shown, verify the right hand frame Bracket is fully seated into the right Housing before installing the left hand Housing.



3. Install wiring connections of the Motor assembly from Trigger Switch (red and black wires) per wiring diagram (Red to M+ or M1, Black to M- or M2).



4. Install the Plastic Housing left hand from the assembly as shown in the figure.



5. Keep the assembly on the work bench facing the cover in the direction shown in the figure.



6. Install 6 screws (#8 X 1.25) from the main body of the Housing.



7. Install 6 screws (#6 x .75) in Handle.



Note: When replacing the Housings with a Housing Service kit, be sure to affix **ALL** appropriate labels from the service kit onto the new housings, using the housings being replaced as a guide for placement of your new labels. Your service kit will include extra labels for other languages and markets that can be discarded after you select the ones needed for your product.

2.4 MOTOR

2.4.1 REMOVAL OF MOTOR

Before removing the Motor follow the below instructions:

1. Remove the Motor Assembly from the End Housing by removing the 2 screws (M5 x .8 x 12), Qty 2 from the casting securing the Motor using a 4mm Allen Wrench.



2. Tap the motor with dead blow hammer to remove the Motor Assembly from the Chassis assembly.



3. After removal of the Motor assembly from the Chassis, keep the Motor assembly on the work bench.



2.4.2 ASSEMBLY OF MOTOR

8. Install the Motor assembly in to the Chassis assembly.

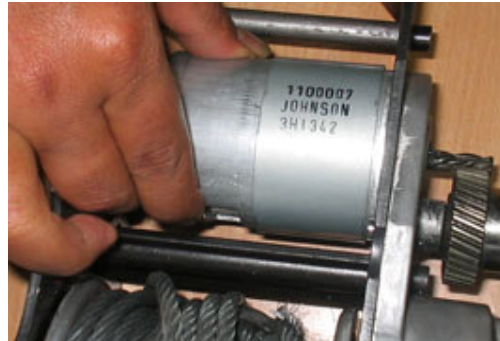

9. Tighten the two CapScrews to secure Motor assembly in position.

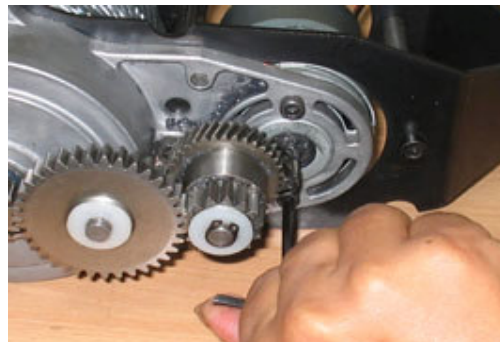

10. Install Motor leads to top terminals of Switch per wiring diagram (Red to M+ or M1, Black to M- or M2).



2.4.3 INSPECTION OF MOTOR

- Visual inspection.
- Ensure that Motor has been properly placed inside the End Housing and the screw had been properly tightened

2.5 WIRE ROPE ASSEMBLY

2.5.1 REMOVAL OF WIRE ROPE

Note:

Prior to disassembly:

1. Spool out all Wire Rope.
2. Use of gloves is recommended while handling frayed or damaged Wire Rope.
3. Unplug unit / remove Battery before disassembly.

Tasks:

Disassemble the Wire Rope.

1. Push the Wire in the direction of the arrow mark as shown in the figure.

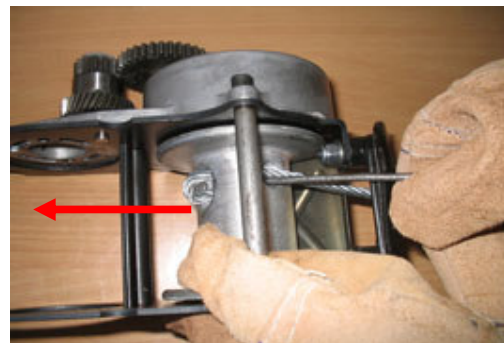

2. Using a punch or drift and hammer, tap the end of the Wire Rope to push the loop back through the Drum.



3. Use the pin remover (punch) to remove the Wire Rope from the Drum.



4. Remove the Stop Button from Drum by using snap ring plier as shown in the figure



5. Straighten the bent Rope and pull the Rope out of Drum hole in the shown direction.



6. Remove the hawse fairlead from the Bracket of the Chassis.



7. Remove and discard the Tension Plate (if equipped).



2.5.2 ASSEMBLY OF WIRE ROPE

1. Assemble the Hawse Fairlead to the Bracket of the Chassis.



2. Tighten the CapScrews with Allen key and opened end wrench.



3. Keep the insulation tape to the edge of the Wire Rope.



4. Insert the Wire Rope into the Drum through the Hawse Fairlead.



5. Pull the wire from the other end of the Drum hole.



6. Bend the Wire Rope and insert in to the same hole in the direction shown in the figure.



7. Pull the Wire Rope from the hole as shown in the figure.



8. Support one edge of the Wire and pull the other Wire as shown in the figure.



9. Verify Wire Rope stop button is inserted into the loop as shown before pulling the Wire Rope tight.



10. Hit wire rope loop with a hammer, so that the Wire Rope will be pushed in to the rope retention hole.



11. Check the Wire Rope so that it enters completely into the Drum hole.



12. Check from the other side of the Drum whether the Wire Rope is perfectly assembled to the Drum.



2.5.3 INSPECTION OF WIRE ROPE

- Inspect the Wire Rope for signs of wear or damage. Worn and damaged parts must be replaced.
 - See the Rope for damage for kinks, cuts, knots, mashed or frayed portions and broken strands.
 - Keep the Rope free from contaminants. Use a clean towel to remove the dirt and debris.
 - Use of light oil on the Wire Rope can prevent corrosion.
-

2.6 SAFETY HOOK



2.6.1 REMOVAL OF SAFETY HOOK

To remove Safety Hook, follow the Instructions:



1. First straighten the bent end of the Cotter Pin by using pliers, and then pull away the Cotter Pin by holding head of the Pin with the help of pliers from the Pin.



2. Remove the Pin from the Safety Hook and Wire Rope.



3. Remove the Safety Hook from Wire Rope.



2.6.2 ASSEMBLY OF SAFETY HOOK

To reassemble Safety Hook follow the Instructions:

1. Place the Safety Hook and align the mounting holes with the loop of the Wire Rope



2. Insert the Pin through Safety Hook and Wire Rope loop.



3. Insert the Cotter Pin inside the hole of the Pin and bend the ends of the Cotter Pin with the help of pliers.



2.6.3 INSPECTION OF SAFETY HOOK

- Inspect the Hook for signs of wear and damage.
 - Hook damage examples: cracks, twisted components, excessive opening, seat wear, loose or damaged safety latch or corrosion.
-

2.7 TAIL HOOK



Original Tailhook Assy



2nd Generation Tailhook Assy
Service Part Tailhook Assy



2.7.1 REMOVAL OF TAIL HOOK

To remove Tail Hook, follow the instructions below:

1. First straighten the bent end of the Cotter Pin, and then pull out.



2. Remove the Pin from the Hook assembly.



3. Remove the Tail Hook from Chassis assembly.



4. Remove Spacer Bracket from Chassis assembly while loosening the capscrew.



2.7.2 ASSEMBLY OF TAIL HOOK

To reassemble Tail Hook follow the instructions:



1. Place Spacer Bracket in Chassis assembly with capscrew and then apply the torque.



2. Take the Tail Hook and align the mounting holes with the Spacer Bracket holes and Chassis assembly.



3. Insert the Pin through the Hook assembly.



4. Insert the Cotter Pin inside the hole of the Pin and bend the ends of the Cotter Pin with the help of pliers.



2.7.3 INSPECTION OF TAIL HOOK

- Inspect the Hook for signs of wear and damage.
- Hook damage examples: cracks, twisted components, excessive opening, seat wear, loose or damaged safety latch or corrosion.



2.8 GEARSETS

- If the gearsets are worn or damaged, the entire PullzAll must be replaced, no replacement parts are available.

2.9 DRUM

- If the drum is worn or damaged, the entire PullzAll must be replaced, no replacement parts are available.



2.10 WIRING DIAGRAM

WIRING DIAGRAM - 75824

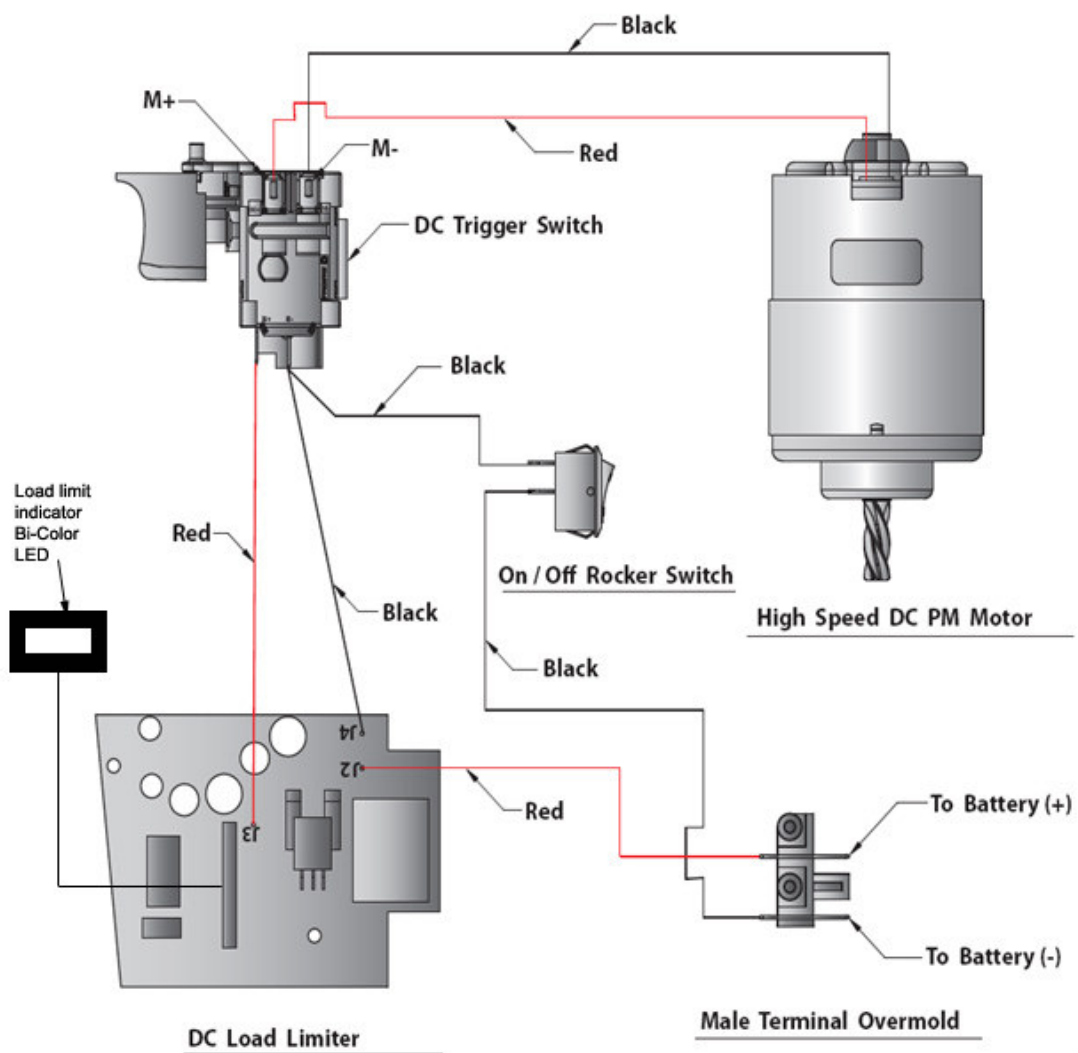

2.10.1 WIRING DETAILS

- Route Red Lead Wire from J3 Terminal on Circuit Board through Wire guides up into handle to Trigger Switch.
 - Route Red Lead Wire (soldered to Male Terminal Support) from J2 Terminal on Circuit Board through Wire guides up to where the male Terminal support is mounted.
 - Route Black Lead Wire from J4 Terminal on Circuit Board through Wire guides up to Trigger Switch.
 - Route the black lead attached to male terminal support to Rocker Switch.
 - Route black lead attached to Black J4 lead at Trigger down through guides and attach to Rocker Switch.
 - Route Motor wires to top of Trigger Switch. Red lead to M+ terminal, black lead to M - terminal.
 - Use tie strap to secure Motor Wires to the right hand frame.
 - Secure the Trigger Switch with switch Retainer and a screw. Secure the Wires in the handle using wire retainer and screws.
 - See Wiring diagram 75824 for installation Wiring schematic
-

Switch Pin-out Table

Manufacturer name is embossed on switch.

VAR SPD PIN-OUT		DEFOND	MARQUARDT
TO/FROM	WIRE COLOR	PIN-OUT	PIN-OUT
POWER SWITCH	BLK	B-	B-
LOAD LIMITER	BLK	B-	B-
LOAD LIMITER	RED	B+	B+
MOTOR BRUSH	BLK	M-	M- OR M2
MOTOR BRUSH	RED	M+	M+ OR M1

2.10.2 REMOVAL OF WIRING

1. Remove the leads from Battery Terminals if required.

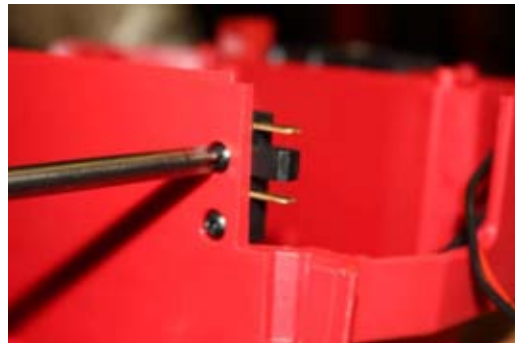

Trigger Switch:

2. Remove the Wires from Trigger Switch.

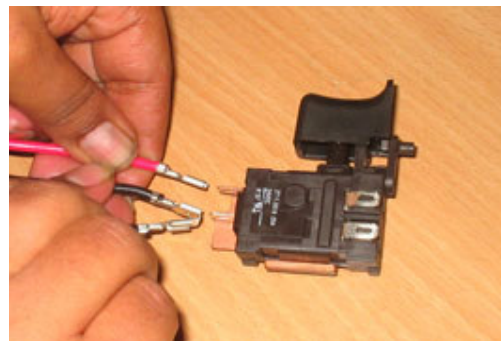

3. Remove the leads from Rocker Switch if required.



4. Take out Load limiter Board Assy from right Plastic Cover after unscrewing all the screws.



5. Remove the 3 leads from out Load limiter Board Assy if required.



2.10.3 ASSEMBLY OF WIRING

1. Install Load limiter Board Assy to right Plastic Cover.



2. Install the two screws at Load limiter Board Assy with the help screw driver right Plastic Cover.

Electronic Load Limiter

3. Push the Plastic Retainers out that secure the LED display



4. Install Battery Terminal into Right Hand Housing using Screws (6 x 0.50), Qty 2.



5. Route Red Lead Wire (soldered to Male Terminal Support) from J2 Terminal on Circuit Board through wire guides up to rear of Housing to where the Male Terminal support is mounted.



Trigger Switch

6. Route Red Lead Wire from load limiter circuit board J3 and black wire from load limiter J4 through wire guides up in to handle to Trigger Switch (Red to B+, Black to B-) Black wire is connected to black wire from rocker switch.

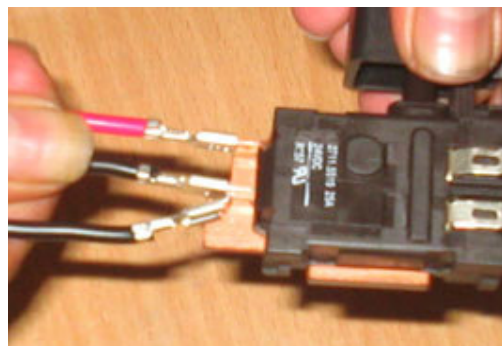

7. Install leads to Rocker Switch



2.10.4 INSPECTION OF WIRING

VISUAL INSPECTION

- While disconnecting the connectors, never pull the Wiring Harnesses. Unlock the connector first and then pull them apart by holding Connectors themselves.
 - While connecting Connectors, also hold Connectors and put them together until they lock securely (a click is heard).
 - While Installing the Wiring Harness, fix it with clamps so that no slack is left.
 - While using a tester for checking continuity or measuring voltage, be sure to insert the tester probe from the Wire harness side.
-

2.11 TORQUE SPECIFICATIONS

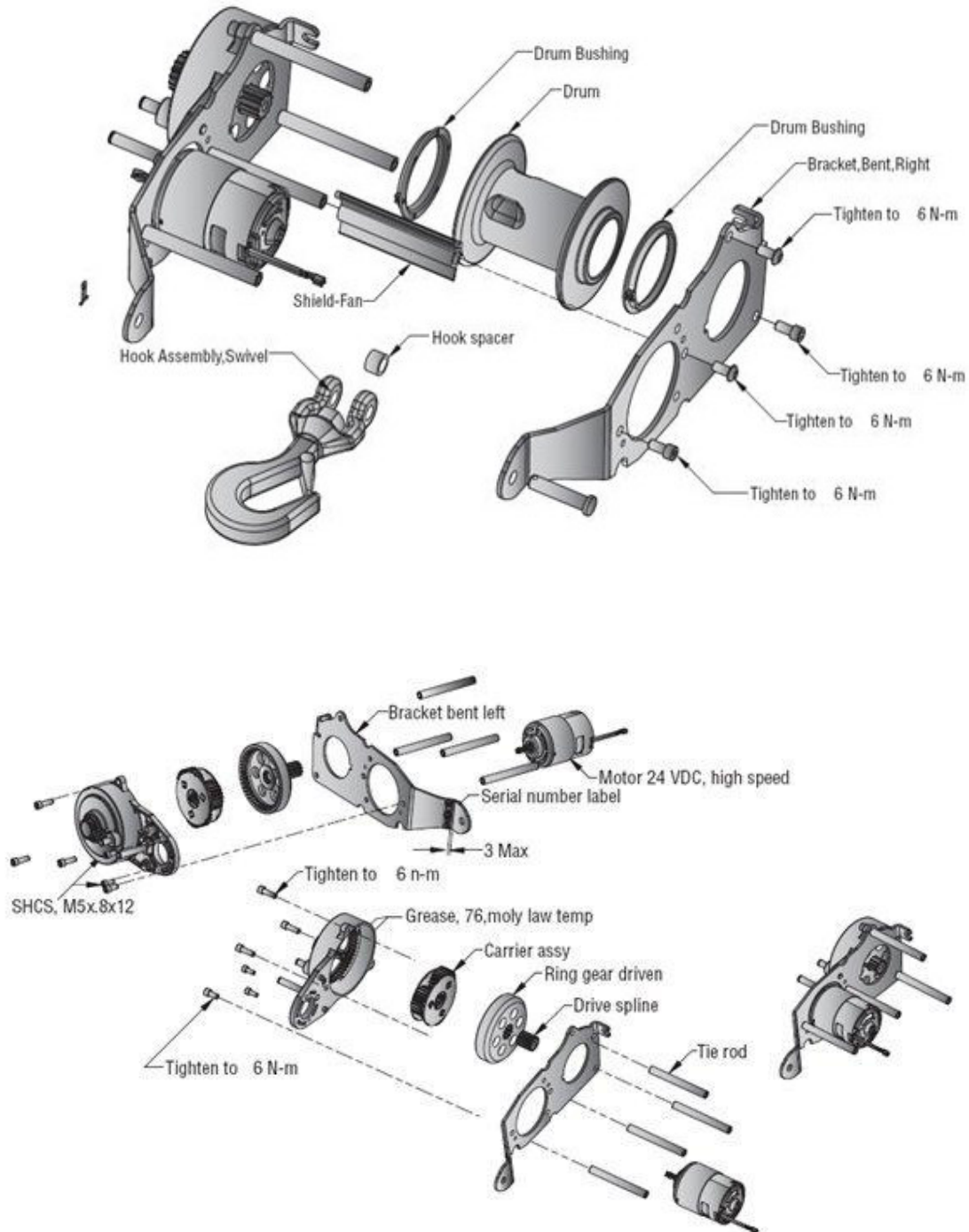

3. PULLZALL TROUBLE SHOOTING

PROBLEM	POSSIBLE CAUSE	CORRECTIVE ACTION
1.1 PullzAll does not power in or pulls slowly.	Battery is not fully charged.	Charge Battery
	Loose connection on Battery or Motor Terminals.	Be sure all connections are tight and clean. Do not let bottom nut or stud turn while tightening.
	Check the speed mode selected	Change mode as required.
	Battery voltage too low due to Battery deterioration.	Replace Battery.
	Worn Trigger Switch	Repair or Replace Switch.
	Worn Brushes/Motor.	Replace Motor
	Poor Wiring Connections.	Check Wiring connections.
	Check for loaded condition whether overloaded.	Use the unit within the permissible load limits.
	Rope is interfacing with Tie Rod or other part of PullzAll.	Rewind Rope on Drum so that it is level and not rubbing on other parts of PullzAll.
1.2 Noise	Motor is hot.	Allow PullzAll Motor to cool for at least 10 minutes between short pulls. Increase cooling time for heavy loads or long pulls.
	Abnormally worn Bushing.	Replace PullzAll.
	Worn or Broken Gearset.	Replace PullzAll
	Motor malfunctioning.	Replace Motor.

1.3 Motor running but not pulling	Damaged Geartrain	Replace PullzAll
1.4 Motor does not run.	Check Battery Condition visually (any short circuit)	Check Wiring condition
	Check Battery condition	Repair or replace it with new
	Faulty Trigger Switch	Repair or replace Switch
	Defective Motor	Replace Motor
1.6 Electrical sparks appear around Motor.	Loose connection of Wires to Motor Terminals.	Replace Motor Assembly.
1.7 Wire harness insulation has melted	Switch held in power in position while PullzAll is stalled.	Replace Wire harness or PullzAll Motor Assembly.
	Poor installation caused Wire insulation to be rubbed off or cut, causing direct short.	Replace Wire harness.
1.8 PullzAll makes squeaking / high pitch noise.	Drum Bushing not lubricated.	Grease Drum Bushings.
1.9 Full speed only, no variable speed control	Ensure trigger is only partially depressed	Replace Variable Speed Trigger switch
1.10 Malfunctioning	Not operating correctly.	Cease operation. Diagnose, Repair or Replace.
1.11 Rapid discharge of Battery	Check for Power Switch Left on during storage.	Always turn unit off when not in use.
	Check for Terminals corrosion	Clean and service
	Defects in charging system such as faulty Regulator,	Check charging system

loose Terminals, etc...

Damaged Wiring.

Check Electrical Circuits

4. SERVICE PART LIST

<u>Description</u>	<u>Part Number</u>
1. Service Part -Motor Assembly 24vdc (Includes Motor & Screws)	77916
2. Service Part - Variable Speed Trigger, 24vdc	77913
3. Service Part - Load Limiter Assembly, 24vdc (Includes LED Bezel, Screws and LED Retention Pins)	86355
4. Service Part - Wire Rope Assembly, PullzAll (Includes Fairlead)	76065
5. Service Part - Rapid Charger-120v	77922
6. Service Part - Rapid Charger-230v	77923
7. Service Part - Tail Hook Assembly	77930
8. Service Part - Front Hook Assembly	78052
