



INSTALLATION INSTRUCTIONS

SEMI Hidden Kit

Part Number: 100044

Application: 2016+ Toyota Tacoma

GENERAL SAFETY PRECAUTIONS

Your safety, and the safety of others, is very important. To help you make informed decisions about safety, we have provided installation and operating instructions and other information on labels and in this guide. This information alerts you to potential hazards that could hurt you or others. It is not possible to warn you about all potential hazards associated with this product, you must use your own good judgment.

CARELESS INSTALLATION AND OPERATION CAN RESULT IN SERIOUS INJURY OR EQUIPMENT DAMAGE. READ AND UNDERSTAND ALL SAFETY PRECAUTIONS AND OPERATING INSTRUCTIONS BEFORE INSTALLING AND OPERATING THIS PRODUCT.

This guide identifies potential hazards and has important safety messages that help you and others avoid personal injury or death. WARNING and CAUTION are signal words that identify the level of hazard. These signal words mean:

▲WARNING signals a hazard that could cause serious injury or death, if you do not follow recommendations. **▲CAUTION** signals a hazard that may cause minor to moderate injury, if you do not follow recommendations.

This guide uses NOTICE to call attention to important mechanical information, and Note: to emphasize general information worthy of special attention.

▲ WARNING

IMPACT AND MOVING PARTS ENTANGLEMENT HAZARD

Failure to observe these instructions could lead to severe injury or death

- **Always** take time to fully read the Instructions and/or Operations Guide, and/or Basic Guide to Winching Techniques, in order to understand your winch and its operations.
- **Always** use extreme caution when drilling on any vehicle. Make sure that all fuel lines, brake lines, electrical wires, and other objects are not punctured or damaged when/if drilling on the vehicle. Thoroughly inspect the area to be drilled (on both sides of material) prior to drilling, and relocate any objects that may be damaged. Failure to inspect the area to be drilled may result in vehicle damage, electrical shock, fire or personal injury.
- **Always** wear safety glasses when installing this kit. A drilling operation will cause flying metal chips. Flying chips can cause eye injury.
- **Always** use extreme caution when cutting and trimming during fitting.
- **Always** remove jewelry and wear eye protection.
- **Never** lean over battery while making connections.
- **Never** route electrical cables:
 - o Across any sharp edges.
 - o Through or near moving parts.
 - o Near parts that become hot.
- **Always** insulate and protect all exposed wiring and electrical terminals.
- **Always** install terminal boots as directed in installation instructions.
- **Always** use appropriate and adequate care in lifting components into place.
- **Always** insure components will remain secure during installation and operation.
- **Always** tighten all nuts and bolts securely, per the installation instructions.
- **Always** perform regular inspections and maintenance on the plow mechanism, fasteners, cable and related hardware.
- **Always** replace all worn or damaged parts before operating.
- **Never** operate this WARN product with damaged or missing parts.

Read installation and operating instructions thoroughly.

⚠ CAUTION

MOVING PARTS ENTANGLEMENT HAZARD

Failure to observe these instructions could lead to minor or moderate injury

- **Always** take time to fully read and understand the installation and Operations Guide included with this product.
- **Never** operate this product if you are under 16 years of age.
- **Never** operate this product when under the influence of drugs, alcohol or medications.

Read installation and operating instructions thoroughly.

NOTICE

EQUIPMENT DAMAGE

- **Never** tow vehicle by attaching a tow bar to the eyelets on the bumper.
- **Never** attach tow bars directly to the bumper. Damage to bumper may occur. WARN bumpers are not designed to be used for flat towing. Consult with the manufacturer of your tow bar system for the proper vehicle tow bar brackets..

Read installation and operating instructions thoroughly.

BEFORE YOU BEGIN

NOTICE



This product may interfere with driver assist systems such as adaptive cruise control and parking assist systems that have sensors or cameras installed in the bumpers or front grill area. If your vehicle is equipped with any of these systems or features, consult your vehicle owner's manual before installing this product. These systems may need to be disabled as a result of installing this product.

TABLE OF CONTENTS

Tools Required.....	page 2
Torque Specifications.....	page 2
Parts List.....	page 3
Installation.....	page 4-8
Maintenance/Care.....	page 8

TOOLS REQUIRED

- Standard wrenches
- Standard sockets
- Hacksaw Blade with Handle (*fine tooth*)

TORQUE SPECIFICATIONS

Please use the recommended torque specifications when assembling this product unless otherwise specified in the instructions.

FASTENER SIZE	FASTENER TORQUE		FASTENER SIZE	FASTENER TORQUE	
	lb-ft	(N.m)		lb-ft	(N.m)
1/4"	8	(11)	M4	(2)	3
5/16"	17	(23)	M5	(4.5)	6
3/8"	30	(40)	M6	(7.5)	10
7/16"	48	(66)	M8	(18)	25
1/2"	74	(100)	M10	(37)	50
9/16"	106	(144)			
5/8"	148	(200)			
3/4"	269	(364)			

PARTS LIST

ID No.	Item No.	Description	Qty.	ID No.	Item No.	Description	Qty.
A1	100045	WINCH MOUNT	1	B1	15834	7/16 X 1 3/4 HEX BOLT	4
A2	100060	SUPPORT BRACKET	2	B2	2146	7/16 LOCK WASHER	4
A3	14867	REMOTE EXTENSION	1	B3	220026	7/16 FLAT WASHER	8
				B4	3693	1/4 IN. FLAT SPACER	4
				B5	2583	7/16 NUT	4
				B6	1319	1/4-20 HEX HEAD BOLT	3
				B7	1324	1/4-20 FLAT WASHER	4
				B8	1322	1/4-20 NUT	2
				B9	1321	1/4-20 LOCK WASHER	2
				B10	29382	ROUND HD SCREW	2
				B11	63241	LOCK NUT	2
				B12	84753	PINE TREE PIN	1

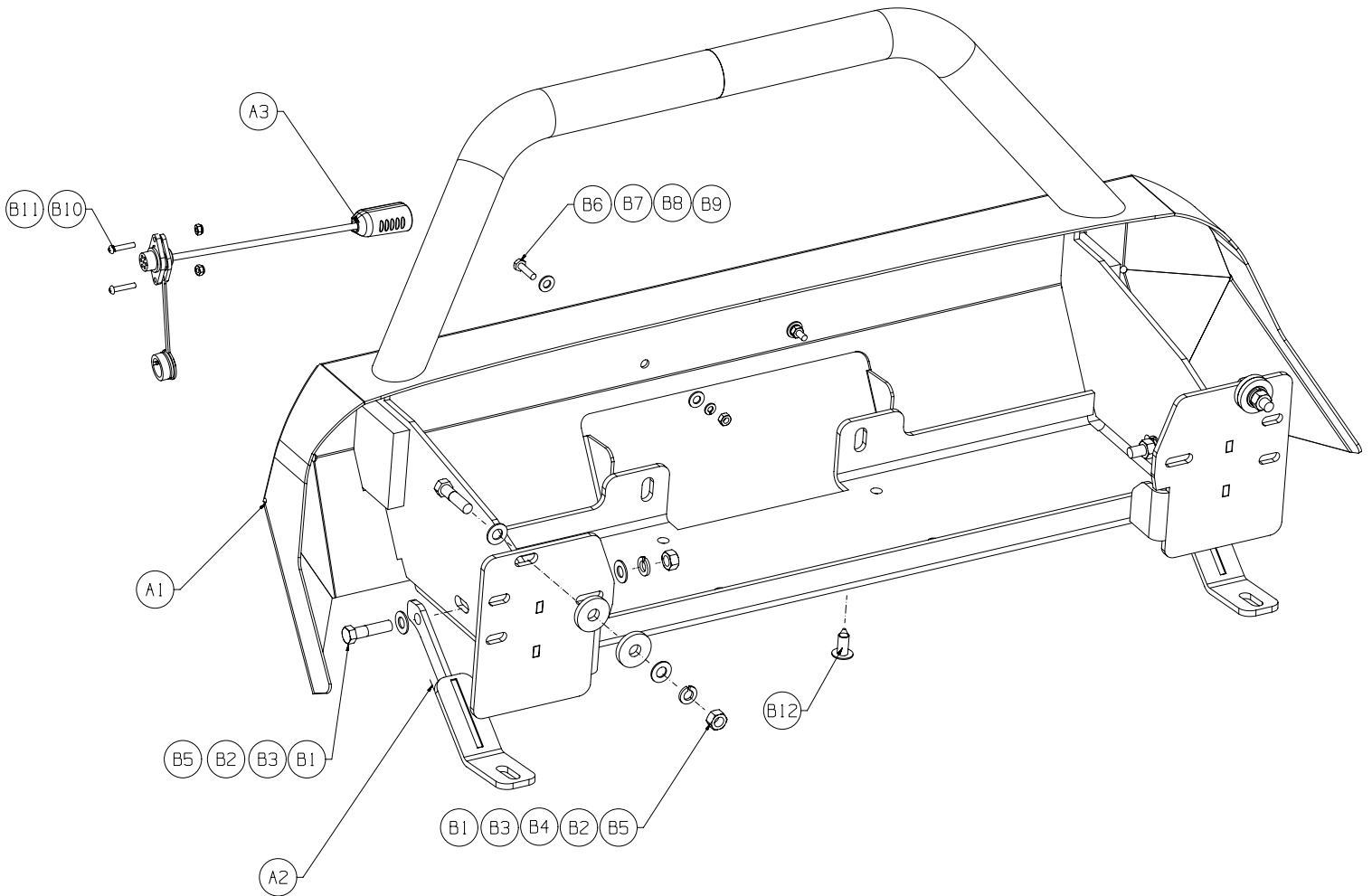

INSTALLATION INSTRUCTIONS

1. Remove license plate.



Figure 1

2. Carefully, remove the front fascia plastic by first removing the screws and plastic push clips from the inner fender skirt. That will allow you to reach between fender skirt and plastic fascia to release clips.



Figure 2

3. Un-clip and remove the plastic cover plate attached to the aluminum cross bar.

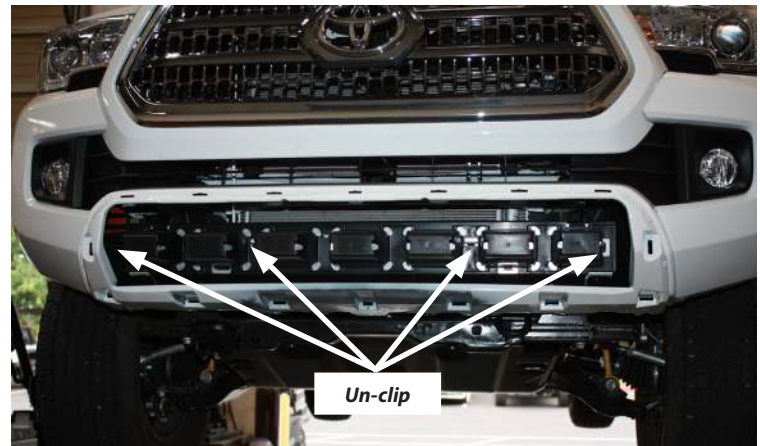

Figure 3

4. Remove the four fasteners from underneath the bumper.
5. Remove the six nuts securing the aluminum cross tube.
6. Un-clip ends of cross tube from behind plastic fascia.

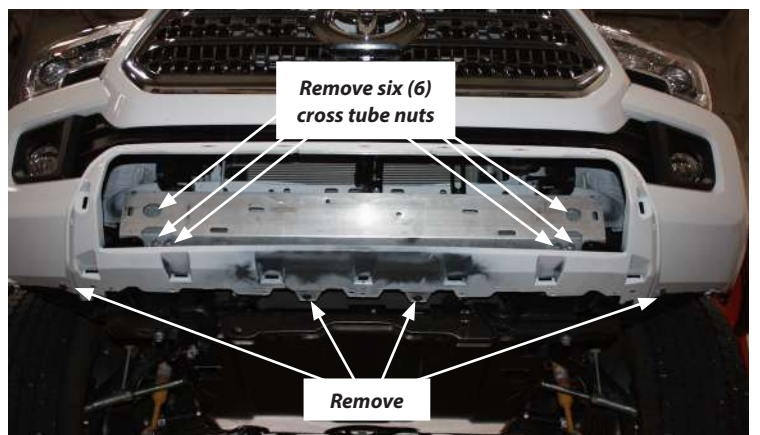

Figure 4

INSTALLATION INSTRUCTIONS

7. Shift cross tube to one side and tilt outwards.
8. Remove the three nuts securing the aluminum frame extension on the side you tilted cross tube out from. **Retain nuts as you will be reusing them.**
9. Remove extension. **NOTE: With one extension removed, you should now be able to shift cross tube over and back towards vehicle, this will allow the tube to freely release from vehicle.**
10. Once the cross tube is out completely, remove second aluminium frame extension, same way as the first.

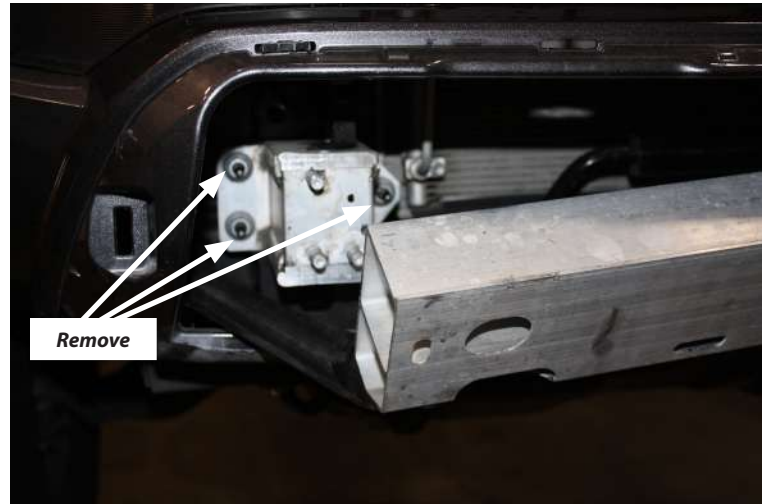

Figure 5

11. Remove the plastic nut from the ends of the aluminum cross tube bracket. **Retain nuts, as you will be reinstalling later.**

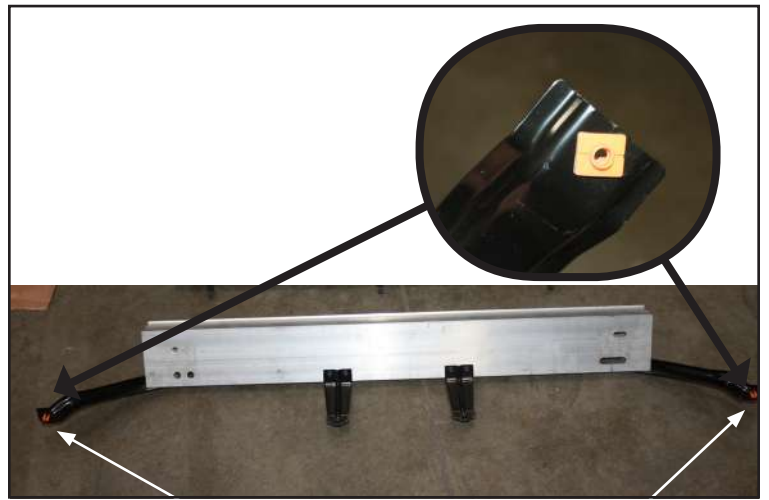

Figure 6

12. Re-insert plastic nut (both sides) back into the inner fender well.

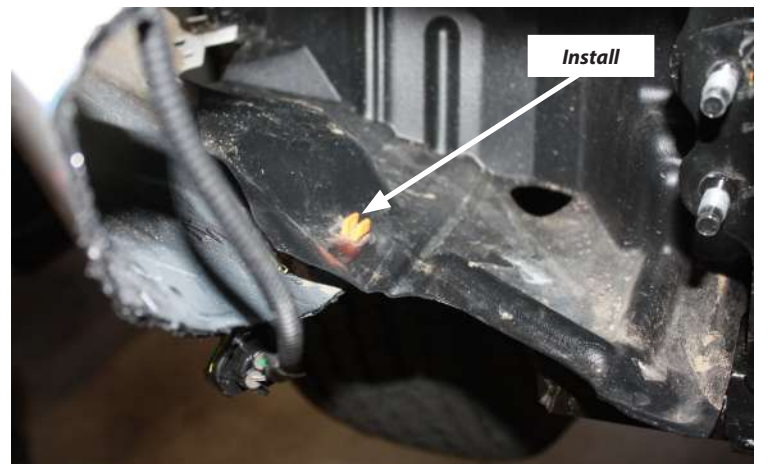

Figure 7

13. Remove the grill by removing the two screws toward the center and the two push/pull clips on top to the outside of grill and.
14. Grab the grill from the middle outer section and carefully pull straight out. **NOTE: Be sure to not break the remaining grill tabs.**

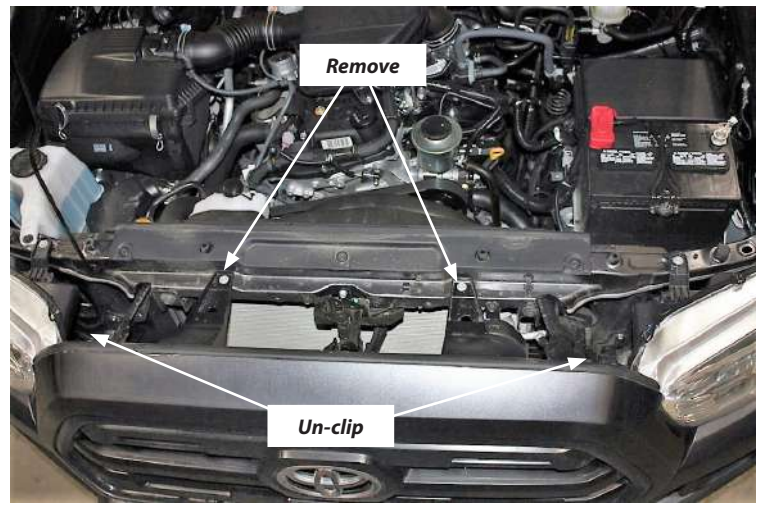

Figure 9

15. Remove the four screws (three at the top and one at the bottom).
16. Remove the six nuts from the cross bar (two in each corner and two in center).
17. Remove the four push/pull plastic clips.

NOTE: If vehicle is equipped with power steering there is one bolt that needs to be removed midway up on the latch.

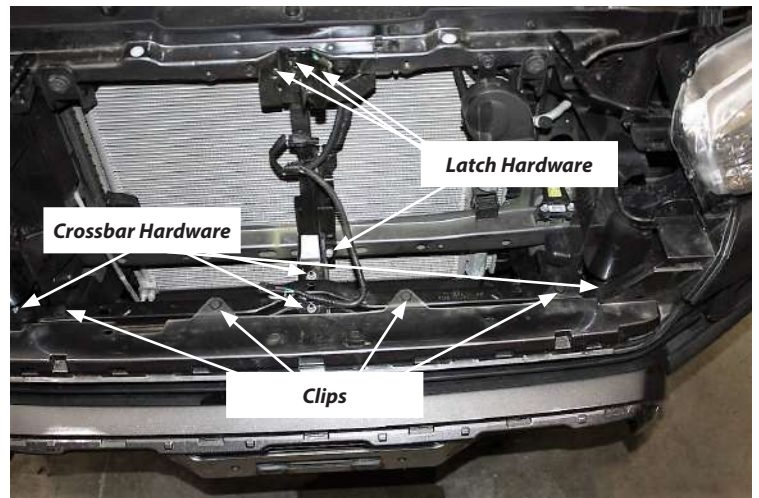

Figure 10

18. Un-clip the wire harness from the cross bar and unplug at its connection.

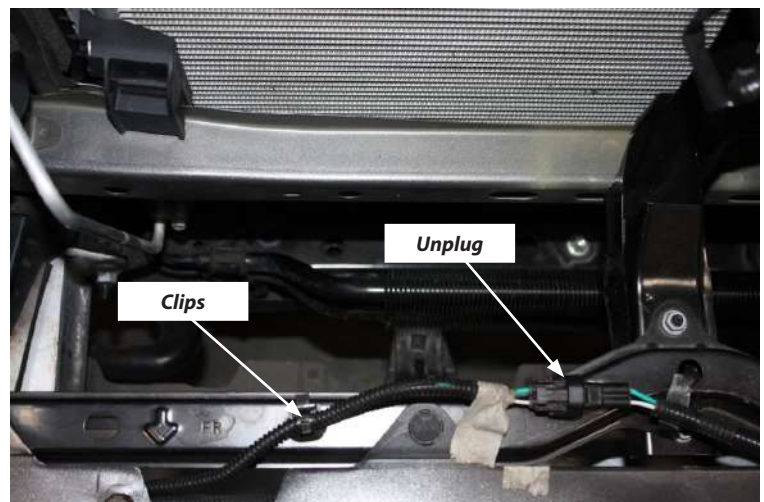

Figure 11

19. Remove the side plastic shrouds on each side of the air conditioning/radiator, by removing the one push pull pin for each side.

NOTE: You will be trimming these after the mount is installed and reinstalling them into original location.



Figure 12

20. Before installing winch, carefully remove entire assembly, latch, crossbar and set aside (be careful of cables that will still be attached to vehicle).

TIP: Before installing the mount, we suggest to install the fairlead to mount, it will ease in installation.



Figure 13

21. Remove the O.E. bolt that holds the slip tube into vehicles frame (both sides).

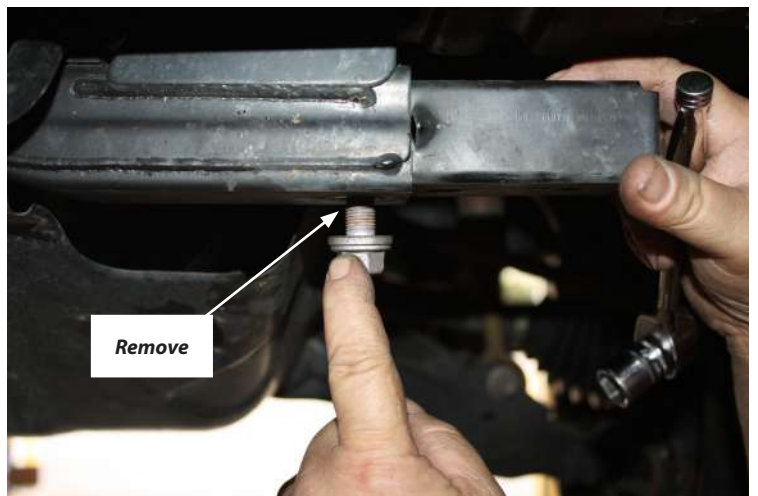

Figure 14

CAUTION

- Always use assistance when moving or lifting heavy parts.

22. With assistance, align the winch mount (A1) to stock frame rail.
23. *Loosely*, attach to frame rail. *NOTE: Refer to exploded view on page 3.*
 - a. Reinstall the three previously removed nuts.
 - b. Install provided hardware (B1, B3, B4, B2, B5).
24. Using slots in mount, center the mount to front of vehicle. Once centered, tighten hardware.
25. Slide the winch mount lower support brackets (A2) between the vehicles plastic and along side the winch mount.
26. Install bracket using original OE bolt and hardware supplied in this kit (B5, B2, B3 and B1).
27. Trim plastic as necessary. Tighten hardware at this time.

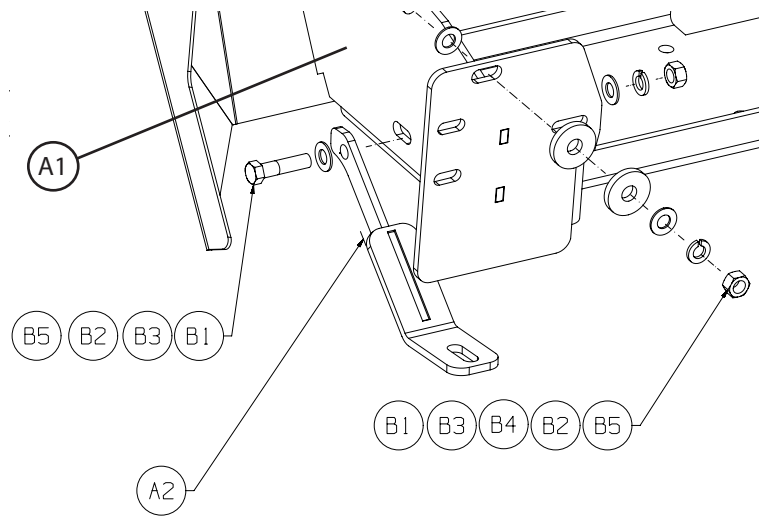

Figure 15

28. In order to have room to drop the winch into position, you will need to move the transmission cooler out of the way. You do this by removing two bolts (one in each bracket) and slide cooler back out of the way.
29. Position the winch with the winch facing you.
30. Have help holding the vehicles plastic and the winch power leads out of the way.
31. Install winch by lowering right side down through the opening where the hood latch was located and just to the left of the power steering cooler, *if equipped*.
32. Once inside the pocket, lower the other side of the winch into the carrier. ***NOTE: Make sure if installing synthetic rope winch you install the rope before installing the winch!***

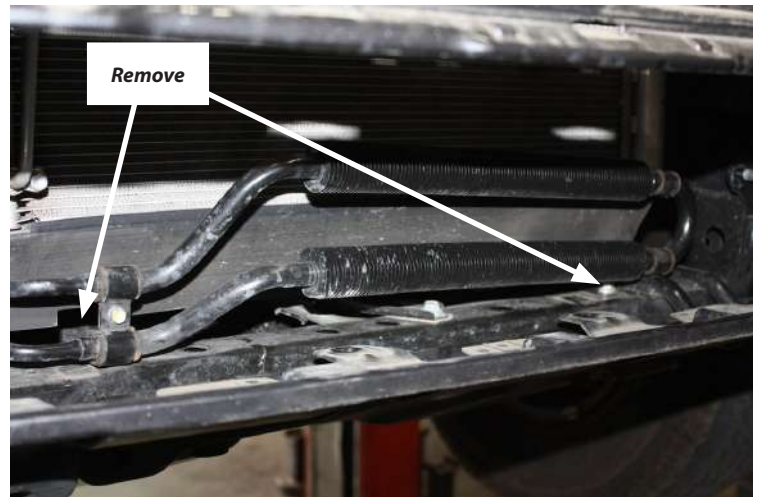

Figure 16

TIP: You may install the winch mounting nuts into winch first before lowering into its location. Use black electrical tape so nuts don't slide out will make installation a little easier.

33. Install winch.
34. Route your winch wires. ***TIP: Use zip ties to keep your wires in a mechanically sound position.***
35. Re-install plastic shrouds (each side) of radiator. ***HINT: You will need cut shrouds to fit around new mount.***
36. Reposition transmission cooler back in place and install bolts previously removed and tighten.
37. Reinstall cross bar, hood latch (*You may need to trim or bend the bottom of hood latch to keep it from hitting the top of the winch.*) and power steering cooler bolt, *if equipped*.
38. Plug in harness and re-clip to cross bar.



Figure 17

39. Install the pine tree clip (B12) in the center of your lower plastic. There should be a hole that lines up in the bottom rear of the winch carrier.

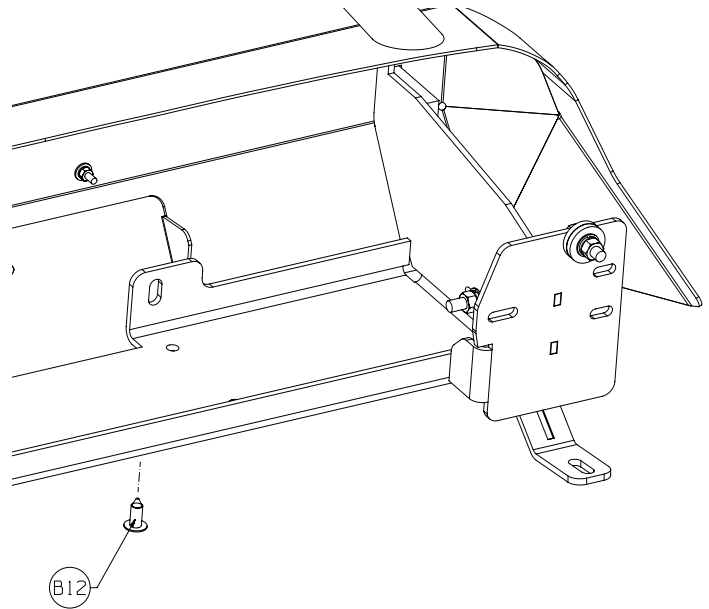

Figure 18

40. Reinstall your vehicles grill and license plate.
41. Tighten ALL hardware.
42. Your Semi hidden kit installation is complete.



Figure 19

MAINTENANCE / CARE

1. Inspect all parts on the winch, winch mount, and related hardware prior to each use. Replace all hardware that appears rusted or deformed.
2. Inspect all nuts and bolts on the winch, winch mount and related hardware prior to each use. Tighten all nuts that appear to be loose. Stripped, fractured, or bent bolts or nuts need to be replaced.
3. Check all cables prior to use. Replace cables that look worn or frayed.
4. Check all moving or rotating parts. Remove debris that may inhibit the part from moving freely.