

# VCC13 VCC

---

## THIRTEEN



### FRONT TENSION ROD

#### **INSTALLATION INSTRUCTIONS:**

**89-94 NISSAN 180SX/240SX/SILVIA S13**

**95-98 NISSAN 200SX/240SX/SILVIA S14**

**99-02 NISSAN SILVIA S15**

**89-94 NISSAN SKYLINE R32 (RWD)**

**95-98 NISSAN SKYLINE R33 (RWD)**

**99-02 NISSAN SKYLINE R34 (RWD)**

#### **PART NUMBERS:**

**V00-TENS-0100**

**V00-TENS-0200**

## RECOMMENDED TOOLS AND SUPPLIES

- General Mechanics Tool Set
- Jack and Stands
- Small Hammer or Mallet
- Torque Wrench

## PART BREAKDOWN

NOTE: For any OE hardware please refer to OEM service manual for torque specifications. For all included hardware please torque to specifications shown below.

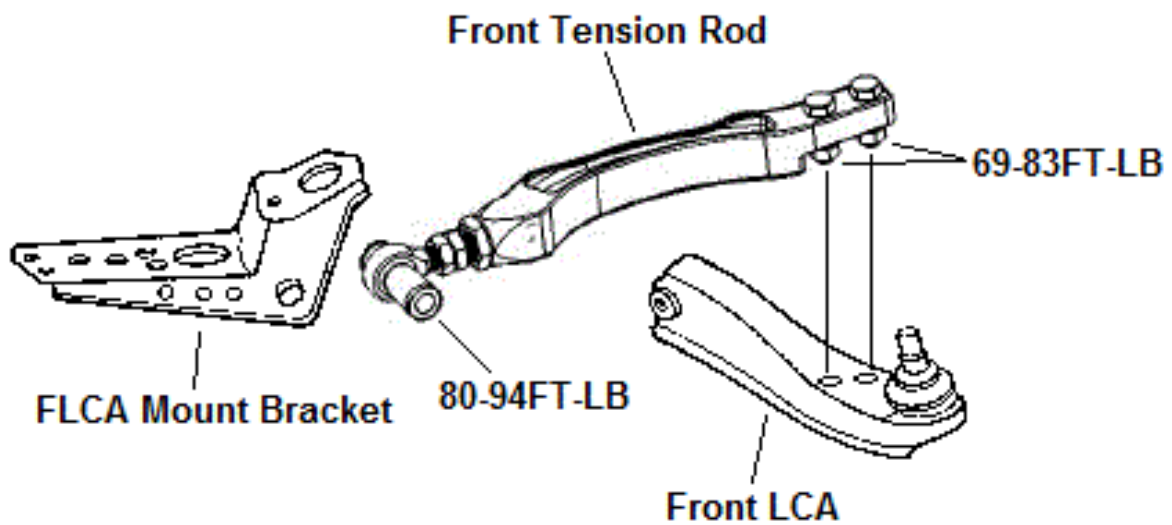

# INSTALLATION PROCEDURE

- Step 1:** Lift the vehicle to a safe height using the recommended factory lift points to work underneath the suspension. Ensure to place safety jack stands where recommended by Nissan before anyone goes underneath the car (unless using a vehicle lift with safety locks).
- Step 2:** Make sure the front wheels are out of the way to access the bolts securing the front tension rods.
- Step 3:** Use a 17mm socket to remove the two bolts underneath the front lower control arm that secures the tension rod.
- Step 4:** Use a 17mm socket and 17mm wrench to remove the bolt from the tension rod bracket. A hammer or mallet may be used to assist removal.
- Step 5:** Now pair up the adjustable tension rods to compare lengths. Recommend to adjust to stock length and then play with the length afterwards to adjust caster.
- Step 6:** Ensure the tension rods are placed on the correct sides. Underneath the tension rod, the part should be engraved with either R or L for indicated placement. The curve within the tension rod's design is for maximum clearance for tires and wheels at full lock.
- Step 7:** Use a socket and wrench to reconnect the tension rod to the bracket. **Torque** the bolt to **80-94 ft-lbs**. Secure the length of the tension rod by ensuring the jam nuts are tight.
- Step 8:** Now use a socket and wrench to attach the tension rod end to the front lower control arm with the supplied bolts and lock nuts. Then **torque** them to **69-83 ft-lbs**.
- Step 9:** Place the wheels back on and torque the lug nuts in accordance via service manual.
- Step 10:** Lower vehicle safely back to the ground and perform a vehicle alignment. You are finished!

## ROD END ADJUSTMENT GUIDELINES

When adjusting rod end to desired position, adjust so that the rod end and adjuster have approximately the same amount of thread showing. Always use the jam nuts to secure the rod end and adjuster. Never tighten the rod end into the adjuster or the adjuster in the lower control arm as a jamming mechanism.

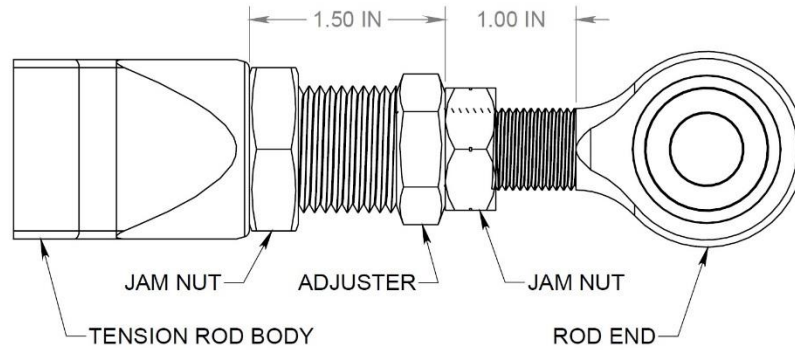

CORRECTLY ADJUSTED (MAX ADJUSTMENT SHOWN)

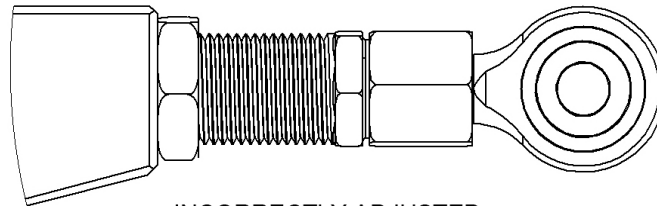

INCORRECTLY ADJUSTED  
INSUFFICIENT THREAD ENGAGEMENT ON ADJUSTER

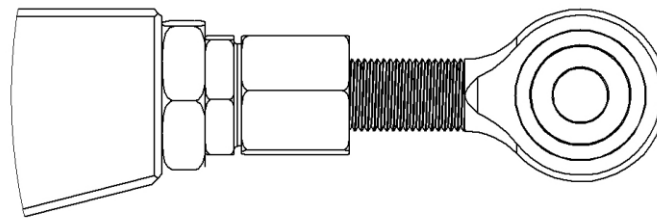

INCORRECTLY ADJUSTED  
INSUFFICIENT THREAD ENGAGEMENT ON ROD END

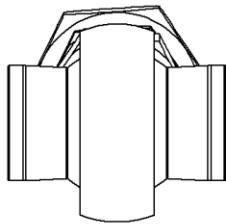

CORRECTLY POSITIONED

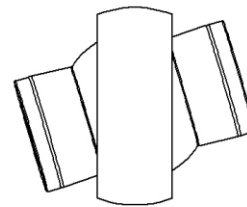

INCORRECTLY POSITIONED  
TOO MUCH STATIC ROD END MISALIGNMENT