



RAISING THE STANDARD
IN RACING SUSPENSION

MADE IN THE USA

NISSAN/INFINITI FRONT ADJUSTABLE SWAY BAR END LINKS

09+ NISSAN 370Z | 07-08 G35 SEDAN | 08-13 G37 | 11-13 M37 | 11-13 M56 | 14+ Q50 | 15 Q40 | 2014+ Q60 | 14-18 Q70 | 11-12 G25



V00-ADEL-0400

ALLOWS FOR PROPER CORNER BALANCE ADJUSTMENT
ELIMINATES PRELOAD ON SWAY BARS
CORRECTS SWAY BAR ORIENTATION

INCLUDED:

- 2 X FEMALE HEIM JOINT
- 4 X MALE HEIM JOINT
- 4 X BOLTS
- 4 X LOCKING NUTS
- 8 X MISALIGNMENT SPACERS

It is recommended the installation of all Voodoo13 parts be completed by an experienced suspension tuning professional. With proper installation and maintenance, Voodoo13 suspension products will provide exceptional performance and durability. For any questions, please contact Voodoo13 immediately. Thank you for choosing Voodoo13 for your suspension component needs!

RECOMMENDED TOOLS + SUPPLIES

- General Mechanics Tool Set
- Vehicle Jack and Jack Stands

PART BREAKDOWN

NOTE: For any OEM hardware please refer to OEM service manual for torque specifications. For all included hardware, please torque to the specifications shown below. It is recommended to use a torque wrench when tightening instead of an impact wrench. Apply anti-seize to all hardware threads.

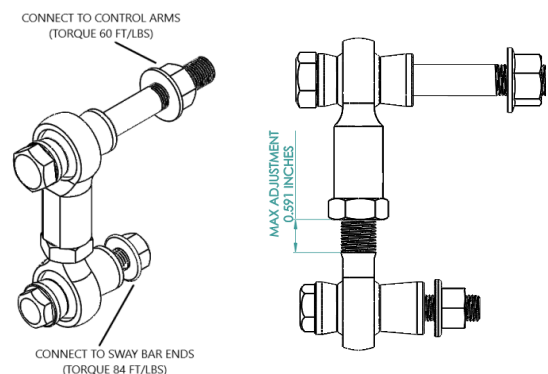

INSTALLATION PROCEDURE

STEP 1: Lift the vehicle to a safe height using the recommended factory lift points to work underneath the vehicle's suspension. Ensure placement of safety jack stands where recommended by the manufacturer's service manual before working underneath the vehicle.

NOTE: Lifting the entire rear suspension where the front wheels are off the ground will ease the process of removing the OEM end links. If you can only lift one side of the vehicle, you will need to use a floor jack on the lower portion of the knuckle to relieve the tension on the sway bar.

STEP 2: Remove the hex nuts securing the end links to the sway bar.

STEP 3: Remove the nut securing the end link to the lower control arm. Place a wrench on the end link nut that sits behind the lower control arm to secure it from moving, then use a socket to remove the main end link nut that is mounted to the lower control arm.

STEP 4: Adjust the Voodoo13 end links to the same length as the factory end links by rotating the threaded heim joint clockwise or counterclockwise. Measurement of the OEM end links is taken from the center of one ball joint to the other.

NOTE: Increasing from the factory end link length is a fine way of increasing the spring rate of the sway bar, however, take into consideration the length of the sway bar does not interfere with anything else such as the lower control arms or the chassis itself. Also, since the end links are independently adjustable in length, you can dial out preload in the sway bar. Preload in the sway bar can be result of corner balancing a vehicle with height adjustable shocks or struts or an uneven height in the suspension.

STEP 5: Connect the end link with the smaller spacer side to the sway bar and connect the bigger spacer side to the lower control arm. Slowly put the supplied flanged locking nut to both bolts.

NOTE: Reinstall the end links with the entire car on flat ground to eliminate preload. Install one end link on one side, then install on the opposite side, sway bar ends first. Then adjust the length of the end link until the other bolt easily inserts into the sway bar.

STEP 6: Once both end link ends are properly secure into place and the proper lengths have been setup, torque both nuts connected to the lower control arm to 60 ft-lbs and torque the nut connected to the sway bar to 84 ft-lbs using a torque wrench.

STEP 7: Once the lengths of the end links are established, tighten the jams nuts against the female hem joint on both sides. Properly torque the jams nuts to 30 ft-lbs using a torque wrench.

NOTE: Ensure that all hardware is torqued to the correct specification. Re-check the hardware torque specification after 50 miles of continuous driving to ensure proper installation.

WARNING

High performance automotive components intended for off-road use only. Installation should be carried out by a qualified facility and installation professional. Improper use or installation may result in injury or death.

ABOUT VODOO13

Headquartered in Mesa, Arizona, Voodoo13 USA is an aftermarket automotive performance part manufacturer specializing in the production of MIL-SPEC grade suspension components for both street and track vehicles. All products are proudly engineered, manufactured and assembled at their 100,000 Square Foot facility in Mesa, Arizona using only the highest quality materials sourced from US suppliers. Since its inception in 2013, Voodoo13 has become a brand synonymous with quality craftsmanship. Voodoo13 has set itself apart from the competition by being trusted both on and off the track by professional drivers and enthusiasts around the world.