

VOLANT COOL AIR INTAKES
 PART NO.: 12856
 INSTALLATION INSTRUCTIONS

12856 PARTS LIST

1	VOLANT FILTER BOX	2	5/8" STRAIGHT FITTINGS	2	SS SELF TAP SCREWS
1	VOLANT FILTER BOX LID	2	5/8" X 4" BREATHER HOSES	1	8 MM BOLT
1	VOLANT AIR DUCT	4	1/4" TRUSS HEAD SCREWS	1	5/16" LOCK WASHER
1	RAM FILTER W/CLAMP	4	1/4" RUBBER WASHERS	1	5/16" WASHER
1	#048 CLAMP	1	3/4" X 20" VINYL TRIM	1	8 MM NUT
1	#056 CLAMP	1	SENSOR GASKET	1	3/8" LOCK WASHER
1	3 1/2" X 3" REDUCER	1	3 1/2" VINYL END CAP	1	8 MM RUBBER BUMPER STUD

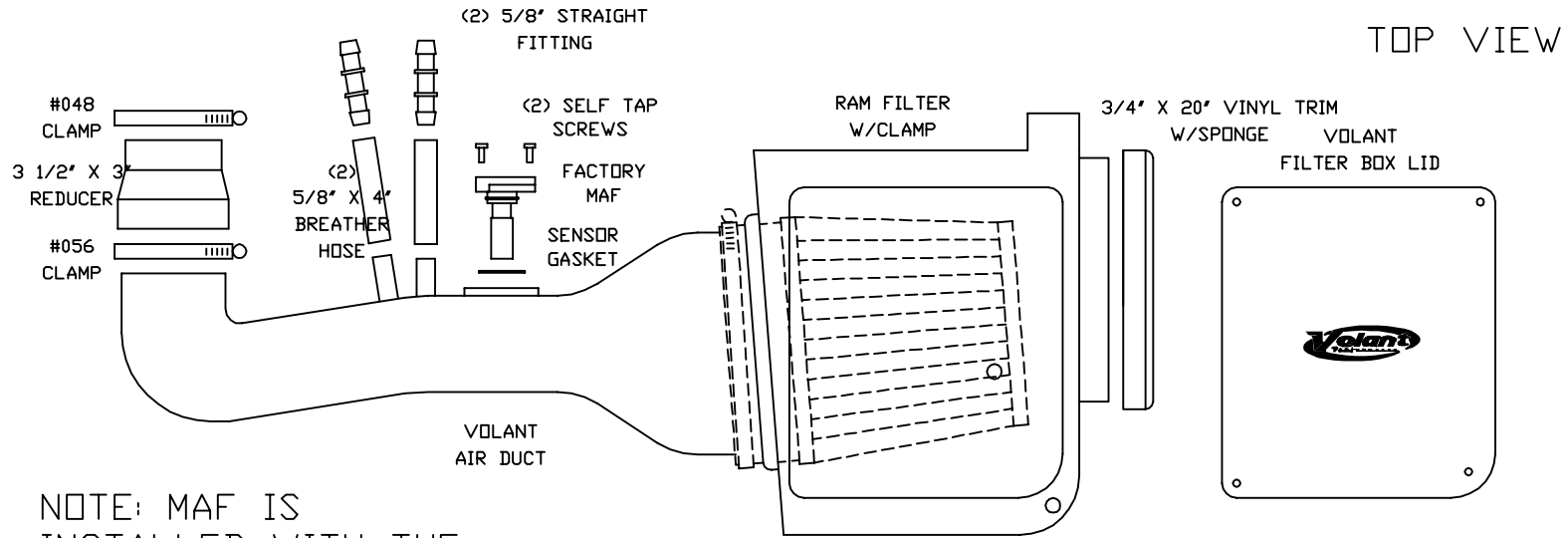

NOTE: MAF IS
 INSTALLED WITH THE
 SILVER SIDE UP.

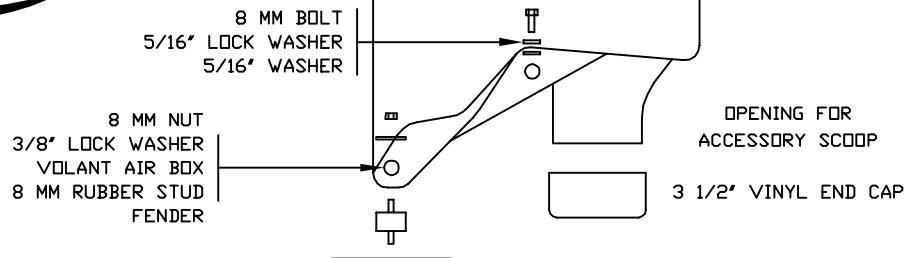
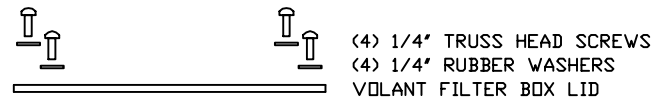

SIDE VIEW



READ INSTRUCTIONS THOROUGHLY BEFORE DISASSEMBLING. DO NOT SKIP ANY STEPS.

INSTALLATION INSTRUCTIONS PART NO. 12856

Installation Instructions:

1. Disconnect the negative battery cable.
2. Remove engine cover by removing 2 10mm bolts.
3. Remove factory air box lid and filter.
4. Remove 2 10mm bolts holding air box down.
5. Disconnect the factory MAF by unclipping it.
6. Remove two breather hose lines from air duct.
7. Loosen clamp-holding duct to throttle body and air box.
8. Remove duct.
9. Remove MAF by removing 2 screws (set aside for re-installation).
10. Pull up on air box to remove from vehicle.
11. Remove remaining 10mm bolt from fender well.
12. Press the 20" trim sponge around the airbox where it meets the fender.
13. Press the 22" trim sponge around the airbox where the filter passes through.
14. Thread the 8mm bumper into the lower mounting hole on the wheel well.
15. Place the Volant box into factory position and tighten down with the hardware provided.
16. Attach the 3.5 to 3" reducer to the volant air duct and tighten with a #56 clamp
17. Slide the air box through the air box opening and press the volant duct into the filter and onto the throttle body and tighten the clamps
18. If you are not connecting a ram a scoop, attach the cap to the bottom port by pressing on
19. Press the MAF gasket onto the MAF sensor and tighten the sensor to the air duct, reattach the harness to the sensor
20. Attach the (2) breather hoses to the volant air duct and press the fittings into the hoses than attach the factory fittings onto the open end of the fittings
21. Attach the lid with the truss head screws
22. Re attach the negative battery cable

WARNING: OVER TIGHTENING HARDWARE MAY ALTAR THE INTEGRITY OF THE VOLANT AIR INTAKE SYSTEM.

BEFORE ROAD TESTING

1. Start engine, leaving the transmission in park and securing the parking brake.
2. Make sure to look and listen for any unusual noises or air leaks. Repair problems if needed.
3. Once completed it will be necessary to check periodically for realignment and tightening of all connections.
4. Once all tests are completed, enjoy the performance of your new Air Intake System.

CARE AND CLEANING

Check the cotton reusable filter periodically and remove any excessive dirt build-up by tapping the filter on the ground and brushing off the loosened dirt. Clean the filter by using Volant's Filter Recharger Kit. Volant's Filter Recharger Kit is designed to restore original air flow. Re-oil every 10,000 miles without cleaning to improve filtering in sand and dirt. Clean only when dirt is very excessive or 50,000 miles.

RECOMMENDED SERVICE PARTS

RECOMMENDED SERVICE PARTS	PART NO.
POWERCORE FILTER UPGRADE	61503
REPLACEMENT COTTON FILTER	5144
PREFILTER	51905
CLEANING KIT	5100

APPLICATION GUIDE

MY	MAKE	MODEL	ENG.
04-10	NISSAN	TITAN	5.6L
04-10	NISSAN	ARMADA	5.6L
04-10	INFINITY	QX56	5.6L

INSTALL



VOLANT COOL AIR INTAKES
 PART NO.: 32856
 INSTALLATION INSTRUCTIONS



32856 PARTS LIST

1	ACCESSORY RAM AIR SCOOP
1	3' X 3' SLEEVE
1	#048 CLAMPS
1	12 MM X 1' BOLT
1	1/2" WASHER
1	1/2" LOCK WASHER

FRONT VIEW

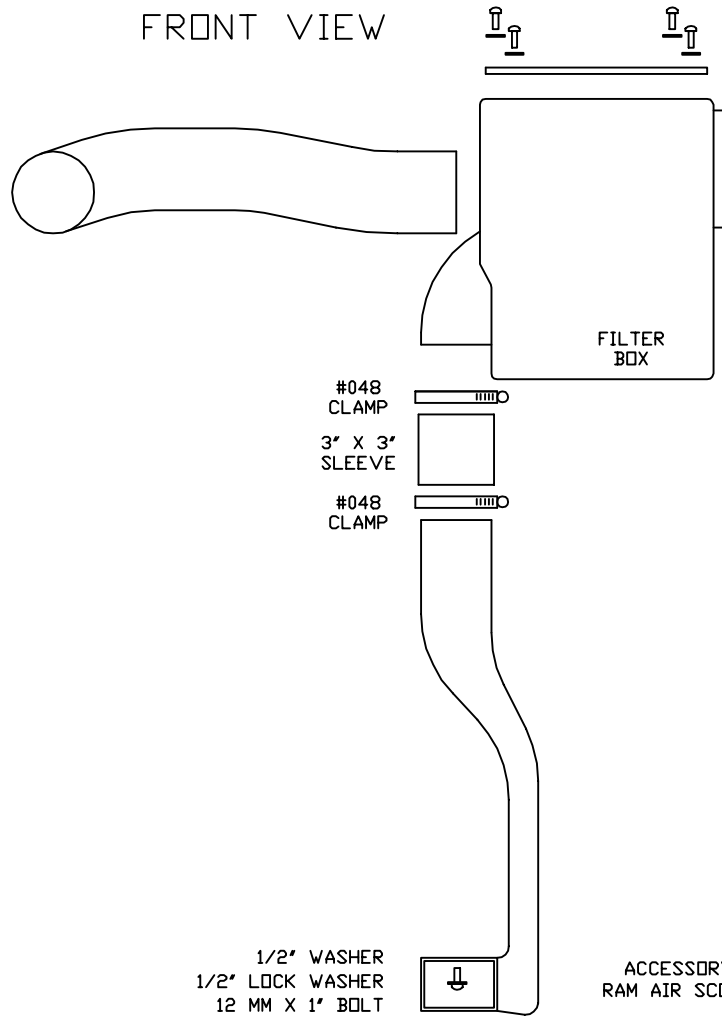

SIDE VIEW

