

VOLANT COOL AIR INTAKES
 PART NO.: 19846
 INSTALLATION INSTRUCTIONS

19846 PARTS LIST

1	VOLANT FILTER BOX	1	3/4" HOSE FITTING	1	1/2" RUBBER GROMMET
1	VOLANT FILTER BOX ADAPTER	1	6 MM BOLT	1	3/16" GASKET
1	VOLANT AIR DUCT	5	1/2"-20 BOLTS	1	16 1/2" RUBBER TRIM W/SPONGE
1	RAM FILTER W/CLAMP	4	1/2"-20 TRUSS HEAD SCREWS	1	3 1/2" HUMP HOSE
1	#048 CLAMP	2	1/4" WASHERS	1	3 1/2" X 3" RUBBER REDUCER
3	#056 CLAMPS	6	1/4" LOCK WASHERS	1	VOLANT BRACKET
1	5/8" HOSE FITTING	4	1/4" RUBBER WASHERS		

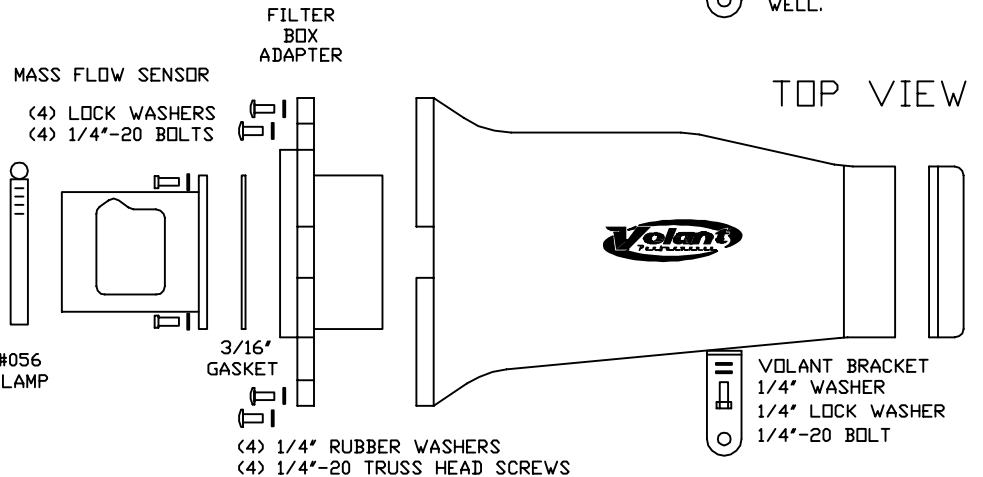

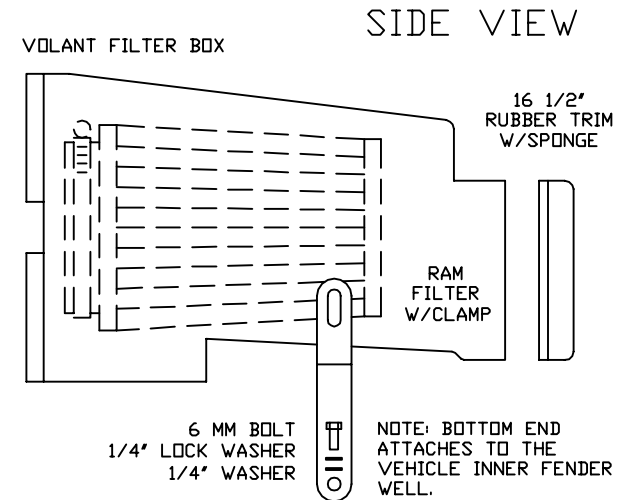
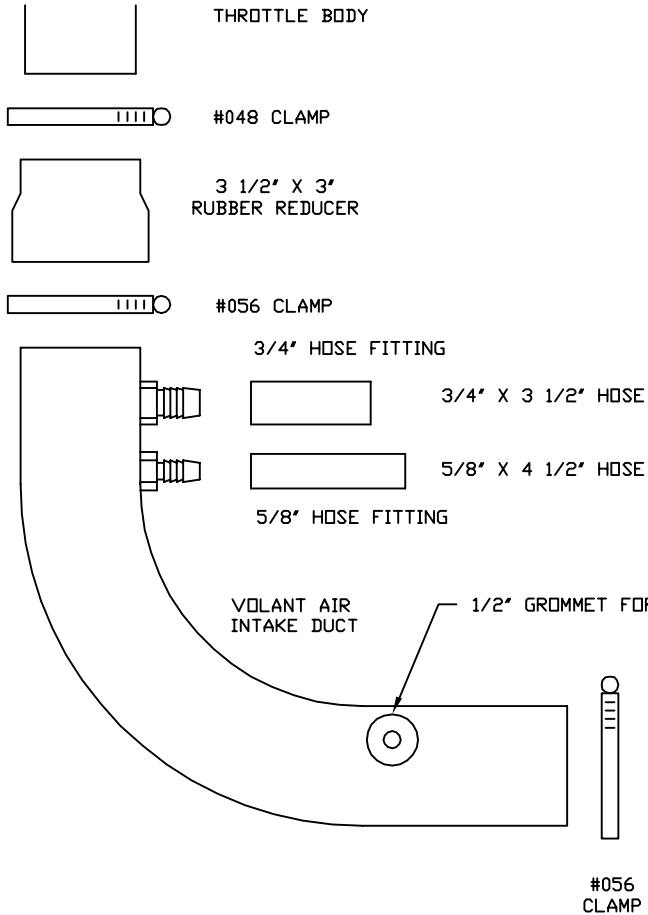

**READ INSTRUCTIONS THOROUGHLY BEFORE DISASSEMBLING.
DO NOT SKIP ANY STEPS.**

INSTALLATION INSTRUCTIONS PART NO. 19846

Installation Instructions:

1. Disconnect the negative battery cable
2. Remove the throttle body cover.
3. Remove the breather hoses from the air duct.
4. Remove the ATS sensor by pulling straight out.
5. Loosen the clamp holding the duct to the throttle body.
6. Pull up on the system and unclip the MAF sensor.
7. Remove the factory intake system.
8. Open the factory air box and remove the MAF cover plate using a flat head screw driver, remove the two bolts holding the sensor in place and remove the MAF sensor.
9. Bolt the MAF sensor to the filter adapter using the MAF gasket and bolts provided.
10. Press the trim sponge to the fender opening of the air box.
11. Attach the air box to the wheel well and tighten the box down with the bracked supplied and clip the harness into the MAF sensor.
12. Press the hump hose onto the MAF sensor and tighten the clamp.
13. Press the reducer onto the throttle body and tighten the clamp.
14. Press the volant air duct into the reducer and hump hose and tighten the clamps.
15. Press the ATS sensor into the rubber grommet.
16. Press the supplied breather hoses onto the factory hard lines and onto the air duct.
17. Re install the throttle body cover and negative battery cable.

WARNING: OVER TIGHTENING HARDWARE MAY ALTAR THE INTEGRITY OF THE VOLANT AIR INTAKE SYSTEM.

BEFORE ROAD TESTING

1. Start engine, leaving the transmission in park and securing the parking brake.
2. Make sure to look and listen for any unusual noises or air leaks. Repair problems if needed.
3. Once completed it will be necessary to check periodically for realignment and tightening of all connections.
4. Once all tests are completed, enjoy the performance of your new Air Intake System.

CARE AND CLEANING

Check the cotton reusable filter periodically and remove any excessive dirt build-up by tapping the filter on the ground and brushing off the loosened dirt. Clean the filter by using Volant's Filter Recharger Kit. Volant's Filter Recharger Kit is designed to restore original air flow. Re-oil every 10,000 miles without cleaning to improve filtering in sand and dirt. Clean only when dirt is very excessive or 50,000 miles.

RECOMMENDED SERVICE PARTS

RECOMMENDED SERVICE PARTS	PART NO.
POWERCORE FILTER UPGRADE	61512
REPLACEMENT COTTON FILTER	5117
PREFILTER	51902
CLEANING KIT	5100

APPLICATION GUIDE

MY	MAKE	MODEL	ENG.
03-04	FORD	EXPEDITION	5.4L

INSTALL

