

VOLANT AIR INTAKE SYSTEMS
 PART NO.: 19754
 INSTALLATION INSTRUCTIONS

19754 PARTS LIST			
			2 6 MM BOLTS
1	FILTER BOX	1	3 1/2' X 2 1/4' SLEEVE
1	FILTER BOX LID	1	4' X 3' HUMP HOSE
1	FILTER BOX ADAPTER	4	1/4"-20 TRUSS HEAD SCREWS
1	VOLANT AIR DUCT	4	1/4' RUBBER WASHERS
1	RAM FILTER W/CLAMP	2	1/4"-20 BOLTS
2	#056 CLAMPS	4	1/4' LOCK WASHERS
2	#064 CLAMPS	2	1/4' WASHERS
		2	5/8' WASHERS
		2	7/8' FENDER WASHERS
		2	6 MM NUTS
		2	STAINLESS STEEL SCREWS
		1	MASS FLOW SENSOR GASKET
		1	1/2' X 17' BREATHER HOSE
		1	1/2' X 14' VINYL TRIM

TOP VIEW

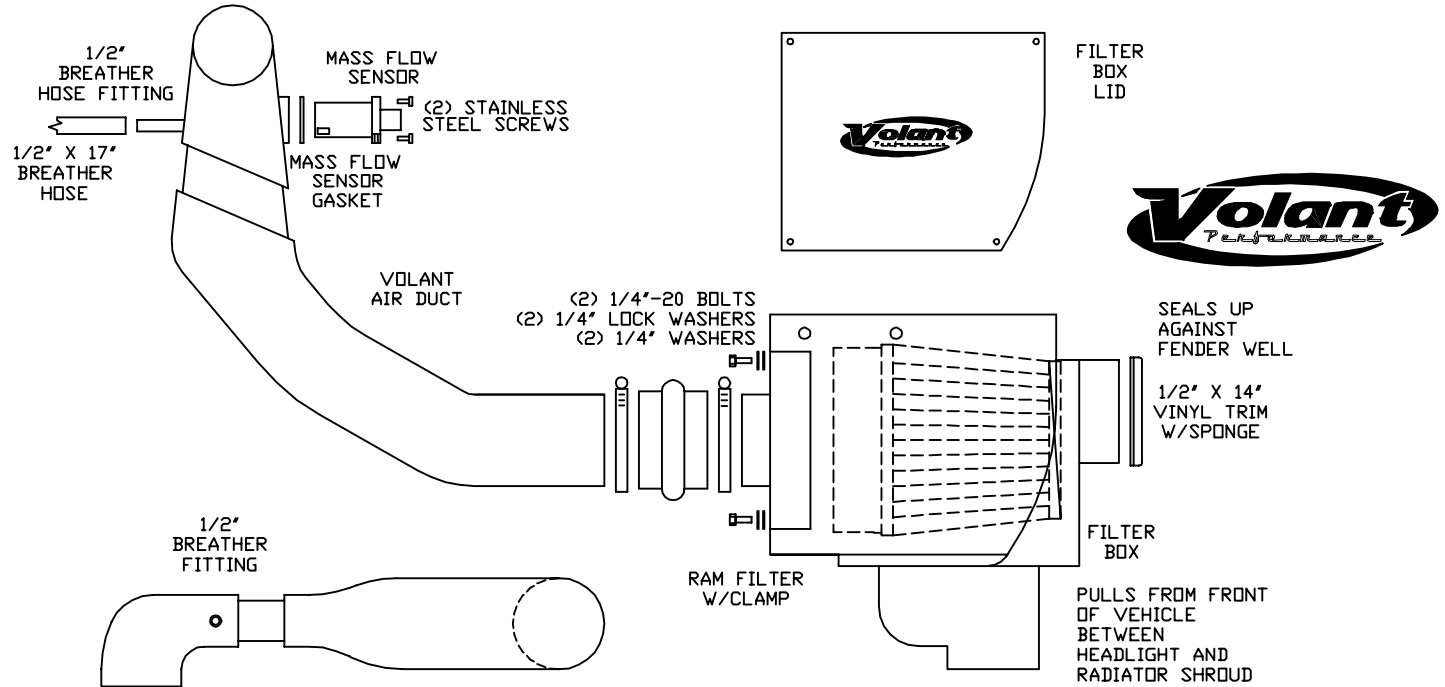

LEFT SIDE VIEW

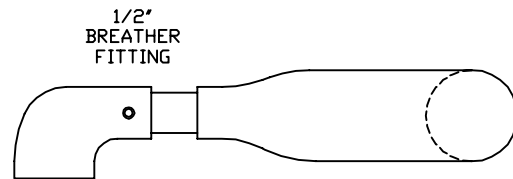

SIDE VIEW

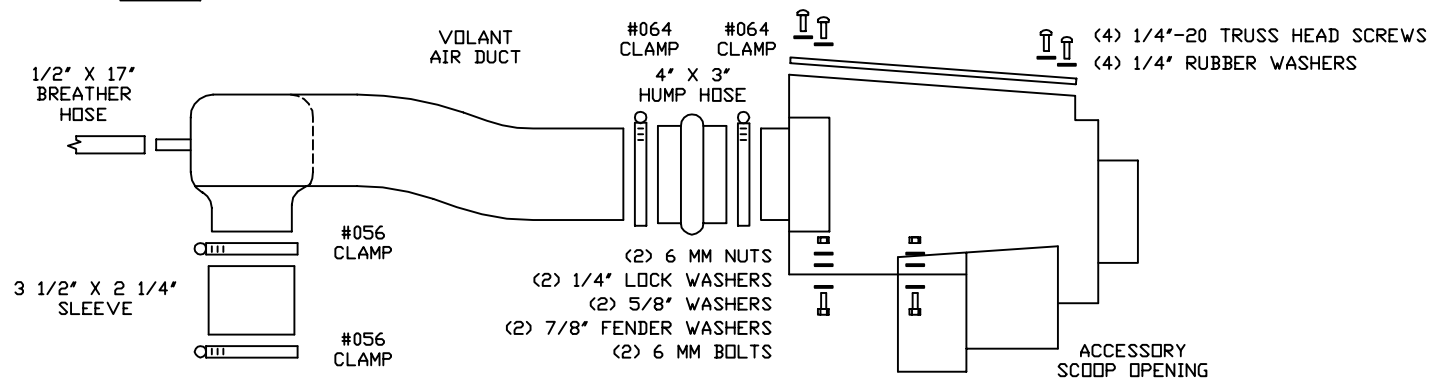



READ INSTRUCTIONS THOROUGHLY BEFORE DISASSEMBLING. DO NOT SKIP ANY STEPS.

INSTALLATION INSTRUCTIONS PART NO. 19754

Installation Instructions:

1. Turn vehicle to the off position. Disconnect the negative battery cable.
2. Unscrew and remove the 6mm bolt located on the middle of the stock air intake duct. Pull the stock air intake duct away from the filter box on the throttle body and from the engine compartment.
3. Remove the bracket that held the stock air intake up. Loosen and remove both bolt on the bottom of the bracket and remove it from the engine compartment. Reinstall the two bolts back with out the bracket.
4. Disconnect the crank case breather hose on the passenger side and the mass flow sensor plug from the sensor on the driver side of the filter box. Loosen the four 6 mm bolts located on the sides of the stock square filter box on the throttle body using a 10mm socket and ratchet. Pull it up and off the throttle body and away from the engine compartment. Remove the other end of the breather hose from the engine fitting and the engine compartment.
5. Remove the mass flow sensor from the stock square filter housing using a phillips screwdriver. Remove the small o ring on the end of the shaft of the mass flow sensor.
6. Reinstall the mass flow sensor and Volant gasket provided onto the Volant air intake duct. Use the stock screws that held the sensor to the stock filter box.
7. Install the Volant filter box on the driver side where the stock unit pulled its air. Line up the holes on the bottom of the box and bolt it down with the bolts provided.
8. Attach the Volant air filter to the adapter inside the Volant filter box.
9. Slip the Volant sleeve onto the end of the Volant duct closest to the mass flow sensor. Use the 56 clamps to secure the sleeve on the duct and place the other clamp on the other end of the sleeve but only tighten enough for it to stay on. Slip the 4" hump hose to the other end of the Volant duct.
10. Connect the Volant duct to the Volant filter box first and the other end to the throttle body. Open the two 64 clamps and wrap it around the 4" hump hose. Once aligned tighten all clamps on the throttle body and the filter box.
11. Reconnect the mass flow sensor on the Volant duct to the engine harness sensor plug. Connect the 1/2 hose provided to the Volant duct and the other end to the engine breather hose fitting.
12. Cover the Volant filter box with the lid and stainless steel screws provided
13. Disconnect the negative battery cable

WARNING: OVER TIGHTENING HARDWARE MAY ALTAR THE INTEGRITY OF THE VOLANT AIR INTAKE SYSTEM.

BEFORE ROAD TESTING

1. Start engine, leaving the transmission in park and securing the parking brake.
2. Make sure to look and listen for any unusual noises or air leaks. Repair problems if needed.
3. Once completed it will be necessary to check periodically for realignment and tightening of all connections.
4. Once all tests are completed, enjoy the performance of your new Air Intake System.

CARE AND CLEANING

Check the cotton reusable filter periodically and remove any excessive dirt build-up by tapping the filter on the ground and brushing off the loosened dirt. Clean the filter by using Volant's Filter Recharger Kit. Volant's Filter Recharger Kit is designed to restore original air flow. Re-oil every 10,000 miles without cleaning to improve filtering in sand and dirt. Clean only when dirt is very excessive or 50,000 miles.

RECOMMENDED SERVICE PARTS

RECOMMENDED SERVICE PARTS	PART NO.
POWERCORE FILTER UPGRADE	61502
REPLACEMENT COTTON FILTER	5144
PREFILTER	51905
CLEANING KIT	5100

APPLICATION GUIDE

MY	MAKE	MODEL	ENG.
04-08	FORD	F-150	5.4L

INSTALL

