

VOLANT COOL AIR INTAKES
PART NO.: 18947
INSTALLATION INSTRUCTIONS

18947 PARTS LIST

1	VOLANT FILTER BOX	4	1/4" RUBBER WASHERS
1	VOLANT FILTER BOX LID	1	1/16" X 1/8" NPT FITTING
1	VOLANT AIR DUCT	1	1/4" X 1/4" NPT FITTING
1	RAM FILTER W/CLAMP	1	1/2" X 10" BREATHER HOSE
2	#056 CLAMPS	1	1" O-RING
1	3 1/2" X 3 1/4" REDUCER	1	1/2" X 13" VINYL TRIM
4	1/4"-20 TRUSS HEAD SCREWS	1	3/8" WASHERS

SIDE VIEW

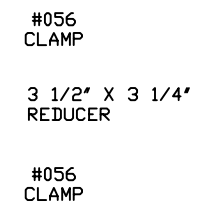
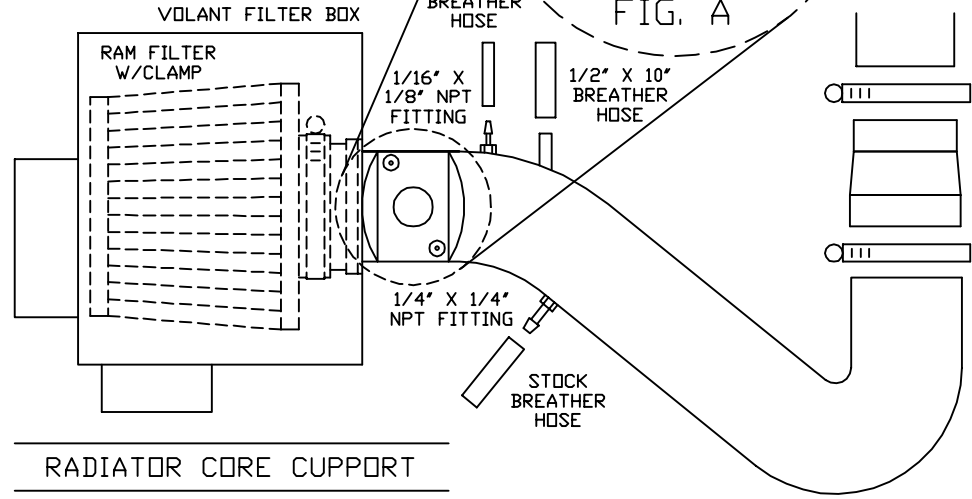
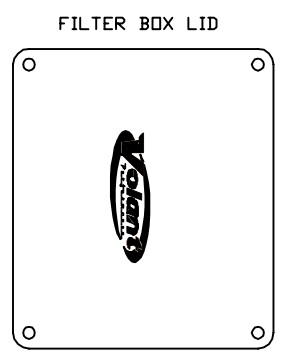
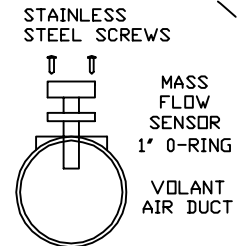
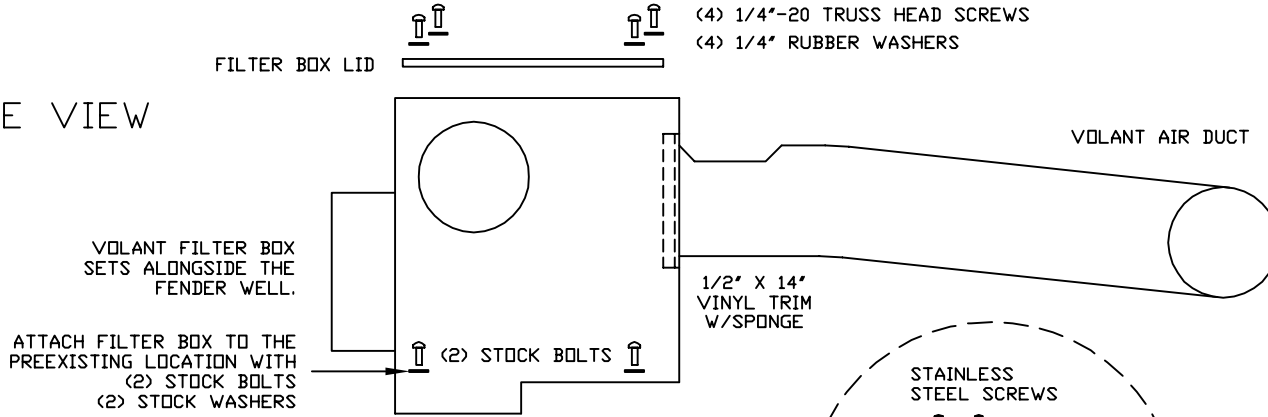

TOP VIEW



**READ INSTRUCTIONS THOROUGHLY BEFORE DISASSEMBLING.
DO NOT SKIP ANY STEPS.**

INSTALLATION INSTRUCTIONS PART NO. 18947

Installation Instructions:

1. Disconnect the negative battery cable,
2. Remove the throttle body cover.
3. Remove the MAF sensor form the factory air duct.
4. Remove the breather hoses form the factory air duct.
5. Loosen the clamps holding the duct to the throttle body and to the air box.
6. Remove the top half of the air box and the factory filter.
7. Remove the three bolts holding the lower half of the air box in place and remove the box.
8. Place the box into the factory position and tighten with the factory hardware.
9. Press the 14in trim around the air duct hole.
10. Press the reducer onto the volant duct and slide the duct through the air box opening and into the filter, tighten all the clamps
11. Attach the breather hoses to the volant air duct.
12. Install the MAF sensor onto the duct using the supplied volant gasket.
13. Reinstall the negative battery cable.

WARNING: OVER TIGHTENING HARDWARE MAY ALTAR THE INTEGRITY OF THE VOLANT AIR INTAKE SYSTEM.

BEFORE ROAD TESTING

1. Start engine, leaving the transmission in park and securing the parking brake.
2. Make sure to look and listen for any unusual noises or air leaks. Repair problems if needed.
3. Once completed it will be necessary to check periodically for realignment and tightening of all connections.
4. Once all tests are completed, enjoy the performance of your new Air Intake System.

CARE AND CLEANING

Check the cotton reusable filter periodically and remove any excessive dirt build-up by tapping the filter on the ground and brushing off the loosened dirt. Clean the filter by using Volant's Filter Recharger Kit. Volant's Filter Recharger Kit is designed to restore original air flow. Re-oil every 10,000 miles without cleaning to improve filtering in sand and dirt. Clean only when dirt is very excessive or 50,000 miles.

RECOMMENDED SERVICE PARTS

RECOMMENDED SERVICE PARTS	PART NO.
REPLACEMENT FILTER	5123
PREFILTER	51909
CLEANING KIT	5100

APPLICATION GUIDE

MY	MAKE	MODEL	ENG.
99-03	TOYOTA	4 RUNNER	4.7L

INSTALL

