

VOLANT COOL AIR INTAKES
 PART NO.: 168576
 INSTALLATION INSTRUCTIONS

168576 PARTS LIST

1	FILTER BOX	6	1/4" RUBBER WASHERS
1	FILTER BOX LID	1	3/4" RUBBER GROMMET
1	VOLANT AIR DUCT	1	3/4" ELBOW FITTING
1	POWERCORE FILTER W/CLAMP	1	3/4" END CAP
1	4' X 3' SLEEVE	1	3/4" X 6' BREATHER HOSE
2	#064 CLAMPS		
6	1/4"-20 TRUSS HEAD SCREWS		

TOP VIEW

REMOVE THE 1/2" STOCK RUBBER GROMMETS FROM THE STOCK FILTER BOX AND MOUNT THEM ONTO THE VOLANT BOX. THE 1/2" RUBBER GROMMETS ARE USED FOR THE STOCK MALE STUDS ON VEHICLE.

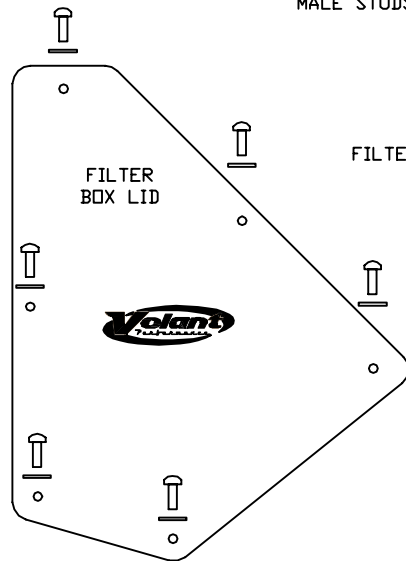

- (6) 1/4"-20 TRUSS HEAD SCREWS
- (6) 1/4" RUBBER WASHERS

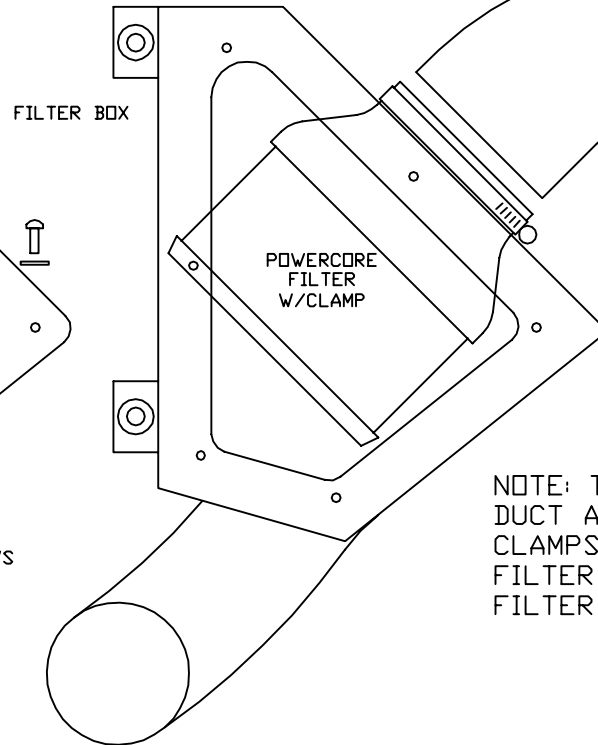

FOR ACCESSORY SCOOP

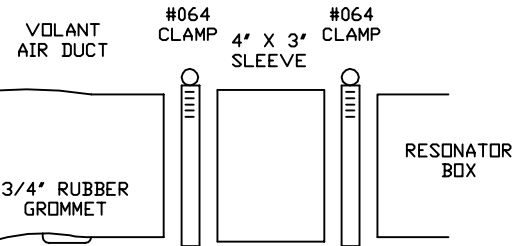

NOTE: ON 2002-03 MODELS, THE BREATHER HOSE IS NON EXISTENT, THEREFORE, PLACE THE 3/4" END CAP OVER THE 3/4" ELBOW FITTING.

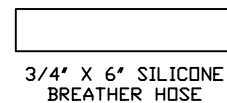

NOTE: ON 2004 MODELS, ATTACH THE 3/4" SILICONE BREATHER HOSE PROVIDED BETWEEN THE THE 3/4" ELBOW FITTING AND THE RESONATER BOX.

NOTE: THE VOLANT DUCT ATTACHES AND CLAMPS TO THE FILTER INSIDE THE FILTER BOX





**READ INSTRUCTIONS THOROUGHLY BEFORE DISASSEMBLING.
DO NOT SKIP ANY STEPS.**

INSTALLATION INSTRUCTIONS PART NO. 168576

Installation Instructions:

1. Switch vehicle ignition to the off position and disconnect negative battery cable.
2. Using a flat head screwdriver or 5/16 nut driver loosen both hose clamps between the resonator box with the HEMI 5.7L V8 emblem and the stock filter box. Then remove the hose off the stock resonator box and stock filter box.
3. On the 2004-06 model pull the 3/4" breather hose off the stock filter box lid. Lift stock filter box out of engine compartment. Remove four (4) rubber grommets from underneath stock filter box. Relocate all four (4) grommets underneath new Volant filter box.
4. Apply 1/2" X 17 3/4" vinyl trim w/sponge around the 5" opening of the Volant filter box.
5. Align new Volant filter box over existing stock mounting posts and press down firmly.
6. Apply 4 x 3" sleeve onto the throttle body and tighten #064 hose clamp using 5/16 nut driver or flat head screwdriver.
7. Feed the Volant air duct through the 5" opening then connect the Volant air duct to 4 x 3" sleeve on the stock resonator box and wrap the #064 hose clamp. DO NOT tighten until everything is in place.
8. Place ram filter in the Volant filter box and connect the Volant air duct to the ram filter w/clamp. Tighten all three clamps.
9. Cover Volant filter box with Volant filter box lid. Align lid opening and fasten all six (6) 1/4"-20 truss head screws with the 1/4" rubber washer. Tighten all six 1/4"-20 screws with a Phillips screwdriver.
10. For 2004-06 models, connect the 3/4" breather hose to the 3/4" elbow fitting on the Volant air duct. On 2002-03 models, attach the end cap over the 3/4" elbow fitting. Note: 2002-03 models do not have a breather hose connection.
11. Make sure everything is properly connected and all clamps are tightened.
12. Reconnect negative battery cable.

WARNING: OVER TIGHTENING HARDWARE MAY ALTAR THE INTEGRITY OF THE VOLANT AIR INTAKE SYSTEM.

BEFORE ROAD TESTING

1. Start engine, leaving the transmission in park and securing the parking brake.
2. Make sure to look and listen for any unusual noises or air leaks. Repair problems if needed.
3. Once completed it will be necessary to check periodically for realignment and tightening of all connections.
4. Once all tests are completed, enjoy the performance of your new Air Intake System.

CARE AND CLEANING

Check the cotton reusable filter periodically and remove any excessive dirt build-up by tapping the filter on the ground and brushing off the loosened dirt. Clean the filter by using Volant's Filter Recharger Kit. Volant's Filter Recharger Kit is designed to restore original air flow. Re-oil every 10,000 miles without cleaning to improve filtering in sand and dirt. Clean only when dirt is very excessive or 50,000 miles.

RECOMMENDED SERVICE PARTS

RECOMMENDED SERVICE PARTS	PART NO.
POWERCORE FILTER	61505
REPLACEMENT COTTON FILTER	5118
PREFILTER	51909
RAM AIR SCOOP	36857

APPLICATION GUIDE

MY	MAKE	MODEL	ENG.
03-08	DODGE	RAM/MEGA	5.7L

INSTALL

