

VOLANT COOL AIR INTAKES
 PART NO.: 16857152
 INSTALLATION INSTRUCTIONS

16857152 PARTS LIST

1	VOLANT FILTER BOX	1	3 1/2" X 2 1/2" SLEEVE		
1	VOLANT FILTER BOX LID	1	3" X 2" SLEEVE	1	BR19846C BRACKET (SHORT)
1	VOLANT AIR DUCT	2	1/4"-20 BOLTS	1	BR26852 BRACKET (LONG)
1	VOLANT RAM AIR SCOOP	3	1/4" WASHERS	2	1/2" RUBBER GROMMET
1	RAM FILTER W/CLAMP	2	1/4" LOCK WASHERS	2	1/2" STRAIGHT FITTING
2	#048 CLAMPS	4	1/4"-20 TRUSS HEAD SCREWS	1	1/2" X 2" BREATHER HOSE
2	#056 CLAMPS	4	1/4" RUBBER WASHERS		

TOP VIEW

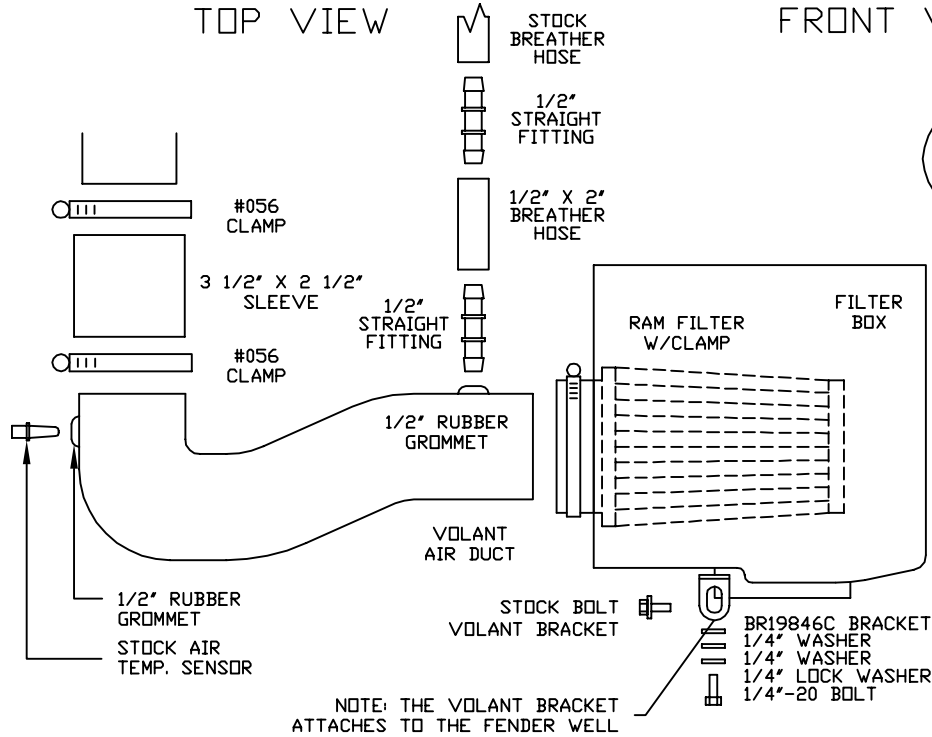

FRONT VIEW

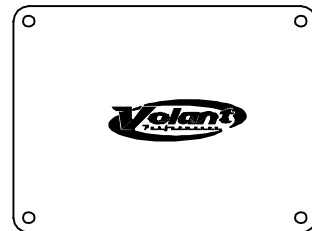
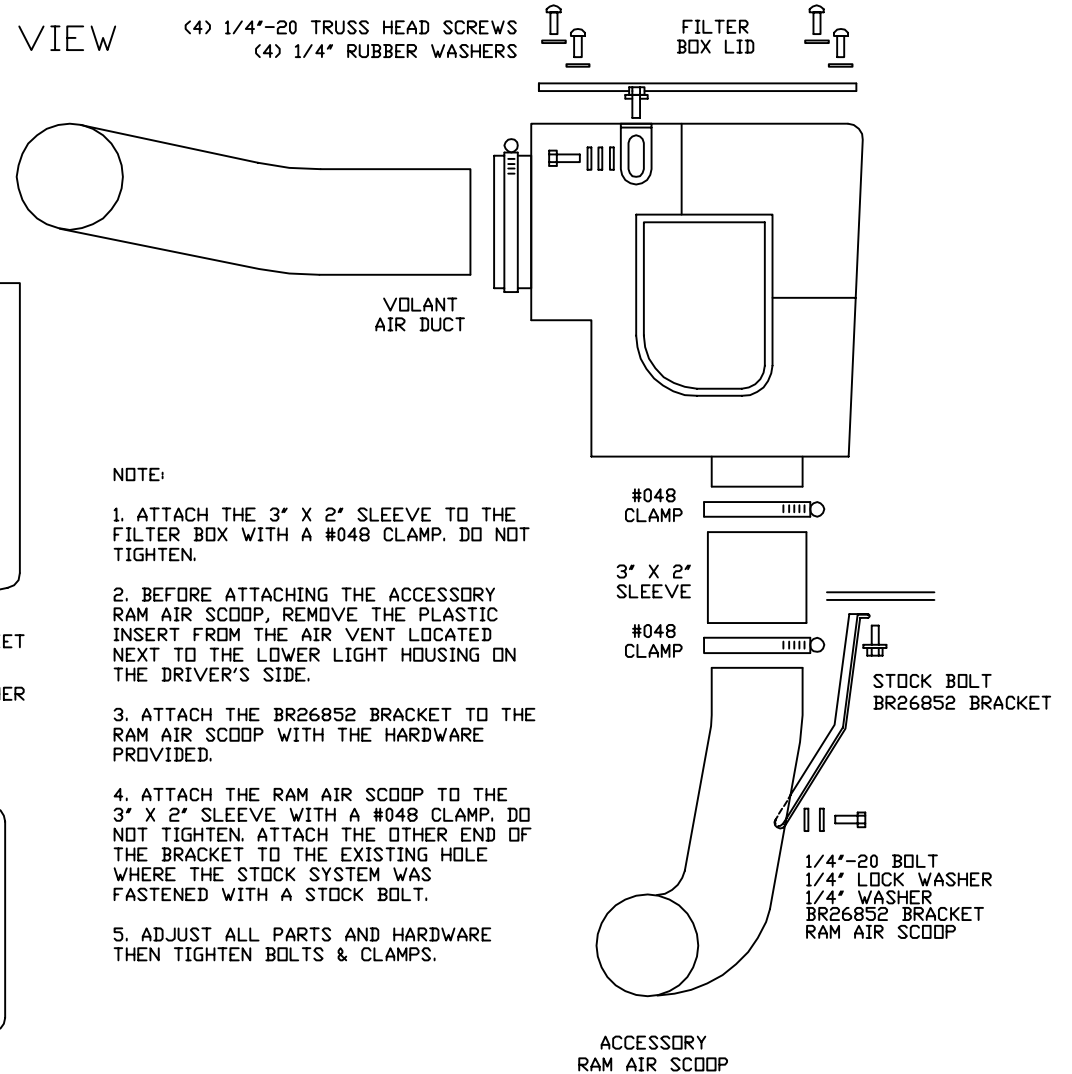



READ INSTRUCTIONS THOROUGHLY BEFORE DISASSEMBLING. DO NOT SKIP ANY STEPS.

INSTALLATION INSTRUCTIONS PART NO. 16857152

Installation Instructions:

1. Disconnect negative battery cable
- Under car:
2. Jack up the front of the vehicle and put vehicle on jack stands
 3. Remove the front skid plate by removing 6 plastic tabs (3 on each side) with flathead screwdriver also remove the 10 7mm bolts and 2 10mm bolts
 4. Remove the rear skid plate by removing the 2 existing 10 mm bolts
5. Remove the factory resonator box
- Under hood:
6. Remove the engine cover by pulling up
 7. Pull stock breather hose located out of the factory box
 8. Remove the factory 10mm bolt holding the box down located on the core support
 9. Remove the air temp sensor by gently pulling STRAIGHT out
 10. Loosen the factory clamp holding on the factory air duct onto throttle body by using a 5/16 socket or nut driver or flathead screwdriver
 11. Remove the factory box and duct
 12. Remove the rubber grommet from the bottom of the factory box
- Installation of Volant Cool Air Intake:
13. Prior to installing Volant box put the Volant fitting inside of the factory rubber grommet and install on the Volant box by pressing the grommet through hole in box
 14. Prior to installing Volant box attach the 3" X 2" Volant sleeve to the bottom of the Volant box using a #48 clamp tighten clamp with a 5/16 socket or nut driver or flathead screwdriver
 15. Prior to installing Volant box install the smaller L bracket to the Volant box using a ¼ lock washer ¼ washer and a 12mm bolt
 16. Place Volant box in factory position and tighten down box with the factory 10mm bolt
 17. Place the ½ straight fitting into the Volant duct, than the Volant ½ sleeve than the Volant ½ fitting IE duct-fitting-breather hose-fitting
 18. Place the 3 ½ X 2 ½" sleeve on the Volant duct and tighten with a #56 clamp using a 5/16 socket or nut driver or flathead screwdriver
 19. Place the Volant filter through the hole in the box and clamp to the Volant duct using a 5/16 socket or nut driver or flathead screwdriver
 20. Place the open end of the 3 ½ X 2 ½ sleeve onto throttle body and tighten the #56 clamp using a 5/16 socket or nut driver or flathead screwdriver
 21. Place the factory breather hose onto the Volant ½ hose fitting
 22. Place the stock air temp sensor into the ½ rubber grommet on the Volant duct
 23. Re-install the factory engine cover by pressing down on factory mounts
- Installation of Volant scoop:
26. Attach the Volant scoop to the bottom of the Volant box and tighten the #48
 27. Clamp with a 5/16 socket or nut driver or flathead screwdriver
 28. Attach Volant bracket the factory bolt location on top of the inner wheel well
 29. Attach scoop to the Volant bracket with ¼-20 bolt ¼ lock washer and ¼ washer. Tighten with 12mm socket or 12mm wrench
 30. Reinstall factory skid plates
 31. Reinstall the negative battery cable

WARNING: OVER TIGHTENING HARDWARE MAY ALTAR THE INTEGRITY OF THE VOLANT AIR INTAKE SYSTEM.

BEFORE ROAD TESTING

1. Start engine, leaving the transmission in park and securing the parking brake.
2. Make sure to look and listen for any unusual noises or air leaks. Repair problems if needed.
3. Once completed it will be necessary to check periodically for realignment and tightening of all connections.
4. Once all tests are completed, enjoy the performance of your new Air Intake System.

CARE AND CLEANING

Check the cotton reusable filter periodically and remove any excessive dirt build-up by tapping the filter on the ground and brushing off the loosened dirt. Clean the filter by using Volant's Filter Recharger Kit. Volant's Filter Recharger Kit is designed to restore original air flow. Re-oil every 10,000 miles without cleaning to improve filtering in sand and dirt. Clean only when dirt is very excessive or 50,000 miles.

RECOMMENDED SERVICE PARTS

RECOMMENDED SERVICE PARTS	PART NO.
REPLACEMENT FILTER	5124
PREFILTER	51902
CLEANING KIT	5100

APPLICATION GUIDE

MY	MAKE	MODEL	ENG.
04-09	CHRYSLER	300	5.7L

INSTALL

