

VOLANT COOL AIR INTAKES
 PART NO.: 15981
 INSTALLATION INSTRUCTIONS

15981 PARTS LIST

1	VOLANT FILTER BOX	4	1/4" LOCK WASHERS	2	ADAPTER GASKETS
1	VOLANT FILTER BOX LID	1	#056 CLAMPS	1	5/13" HEX KEY
1	VOLANT FILTER BOX ADAPTER	1	#060 CLAMPS		
1	VOLANT AIR FLOW DUCT	4	6 MM-25 BOLTS		
1	RAM FILTER W/CLAMP	3	10/32" X 3/4" BOLTS		
5	1/4"-20 TRUSS HEAD SCREWS	4	1/4" X 7/8" FENDER WASHERS		
5	1/4" RUBBER WASHERS	1	3 3/4" X 3 1/2" SLEEVE		

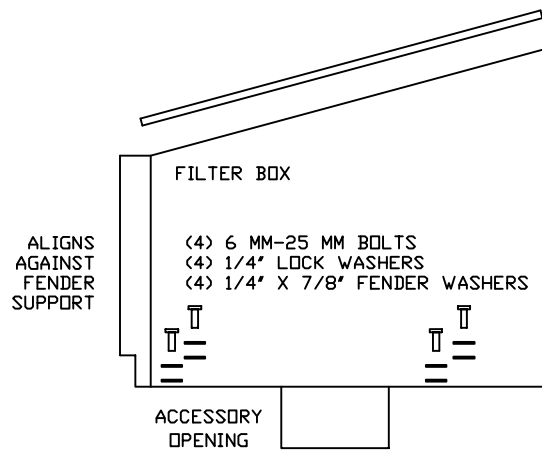

FACTORY RUBBER GROMMET

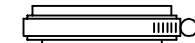

(5) 1/4"-20 TRUSS HEAD SCREWS
 (5) 1/4" RUBBER WASHERS

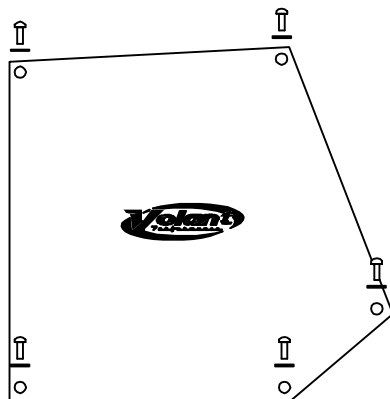

FILTER BOX LID

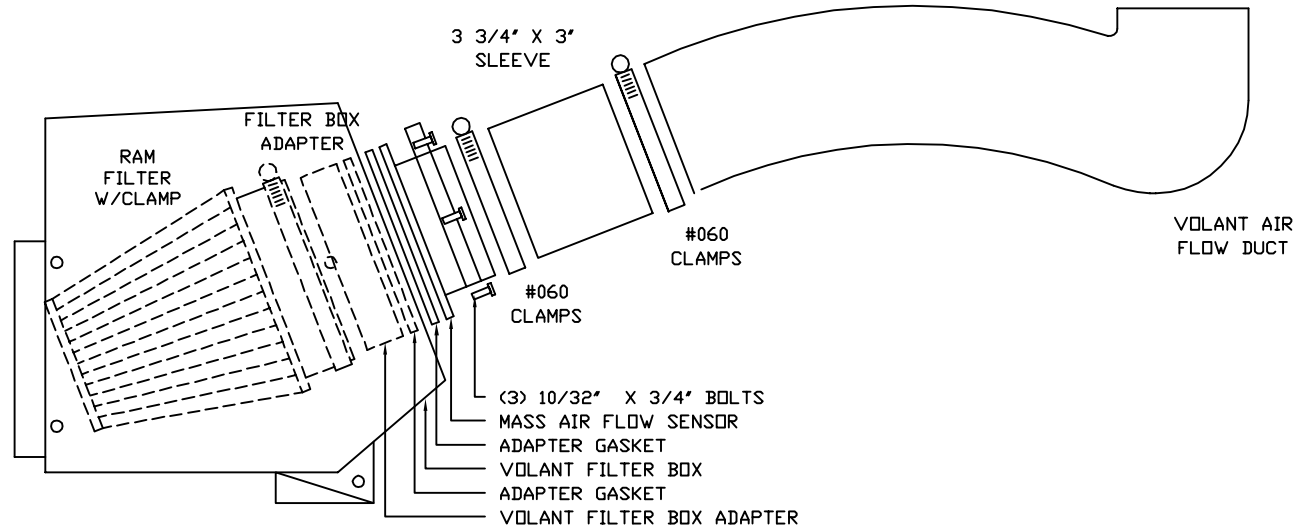



READ INSTRUCTIONS THOROUGHLY BEFORE DISASSEMBLING. DO NOT SKIP ANY STEPS.

INSTALLATION INSTRUCTIONS PART NO. 15981

Installation Instructions:

1. Disconnect the negative battery cable.
2. Loosen the stock rubber grommet hose clamp that connects the stock intake tube to the throttle body. Detach the stock intake tube along with the rubber grommet from the throttle body.
3. On the other end, loosen the hose clamp that connects the air duct to the mass flow sensor. Entirely remove the stock air duct from the engine compartment.
4. Loosen the stock rubber grommet hose clamp that connects your mass flow sensor to the stock filter box. Pull the sensor away from the filter box and set the sensor aside..
5. Remove the stock filter box by pulling straight up and away from the stock filter box mounting tray.
6. Remove the mounting tray from the chassis by loosening all 6 MM bolts with a 10 MM socket or wrench.
7. Mount the Volant box into factory position using the hardware provided.
8. Line up the maf sensor with the filter adapter and tighten together, make sure the maf gasket gets pinched in between the sensor and the air box.
9. Attach the 3.75 x 3 sleeve to the open end of the Maf and tighten with a #60 clamp.
10. Attach the volant throttle body grommet to the volant duct.
11. Press the duct into the sleeve and onto the throttle body and tighten the clamps.
12. Reattach the negative battery cables.

WARNING: OVER TIGHTENING HARDWARE MAY ALTAR THE INTEGRITY OF THE VOLANT AIR INTAKE SYSTEM.

BEFORE ROAD TESTING

1. Start engine, leaving the transmission in park and securing the parking brake.
2. Make sure to look and listen for any unusual noises or air leaks. Repair problems if needed.
3. Once completed it will be necessary to check periodically for realignment and tightening of all connections.
4. Once all tests are completed, enjoy the performance of your new Air Intake System.

CARE AND CLEANING

Check the cotton reusable filter periodically and remove any excessive dirt build-up by tapping the filter on the ground and brushing off the loosened dirt. Clean the filter by using Volant's Filter Recharger Kit. Volant's Filter Recharger Kit is designed to restore original air flow. Re-oil every 10,000 miles without cleaning to improve filtering in sand and dirt. Clean only when dirt is very excessive or 50,000 miles.

RECOMMENDED SERVICE PARTS

RECOMMENDED SERVICE PARTS	PART NO.
POWERCORE FILTER UPGRADE	61517
REPLACEMENT COTTON FILTER	5119
PREFILTER	51906
CLEANING KIT	5100

APPLICATION GUIDE

MY	MAKE	MODEL	ENG.
01-07	CHEVROLET	AVALANCHE	8.1L
01-06	CHEVROLET	SILVERADO HD	8.1L
01-06	CHEVROLET	SUBURBAN	8.1L
01-07	GMC	SIERRA HD	8.1L
01-06	GMC	YUKON XL	8.1L

INSTALL

