

VOLANT COOL AIR INTAKES
 PART NO.: 15966
 INSTALLATION INSTRUCTIONS

15966 PARTS LIST

1	FILTER BOX	2	#064 CLAMPS	1	SENSOR GASKET
1	FILTER BOX LID	2	#072 CLAMPS	2	4 MM PLASTIC SCREWS
1	FILTER BOX ADAPTER	4	6 MM-25 BOLTS	1	3 3/4" X 4 1/4" SLEEVE
1	VOLANT AIR FLOW DUCT	2	1/4"-20 BOLTS	1	4 1/2" X 3 1/2" SLEEVE
1	RAM FILTER W/CLAMP	2	1/4" LOCK WASHERS		
5	1/4"-20 TRUSS HEAD SCREWS	2	1/4" WASHERS		
5	1/4" RUBBER WASHERS	4	1/4" X 7/8" FENDER WASHERS		

NOTE: REMOVE THE ADHESIVE COVER FROM THE FENDER WELL IN ORDER TO INSURE MAXIMUM AIR FLOW.

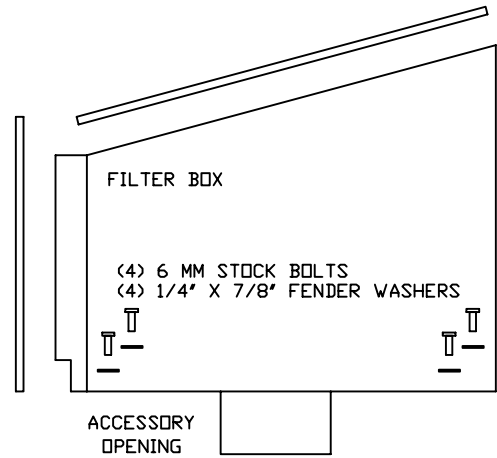

(5) 1/4"-20 TRUSS HEAD SCREWS
 (5) 1/4" RUBBER WASHERS

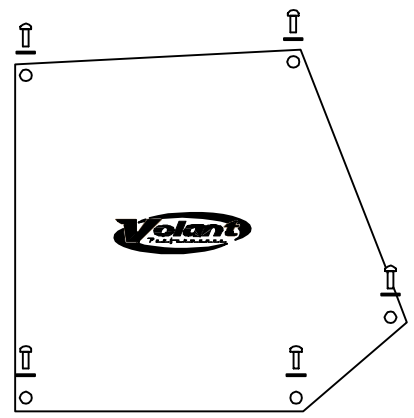

ALIGNS AGAINST FENDER SUPPORT

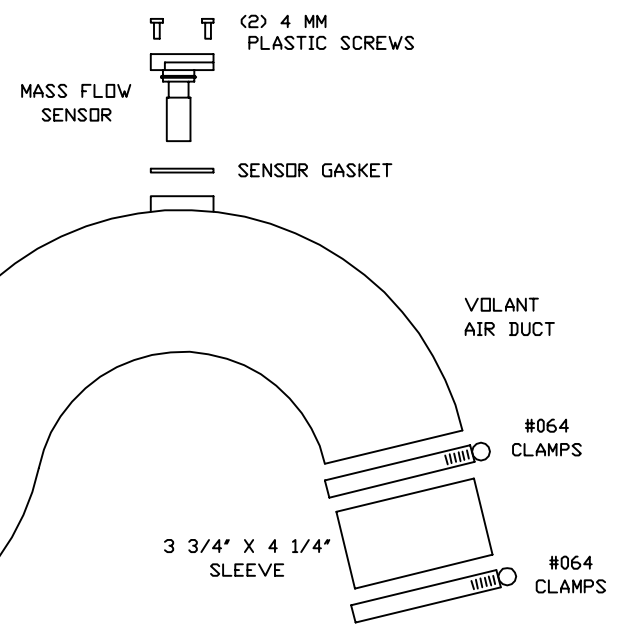
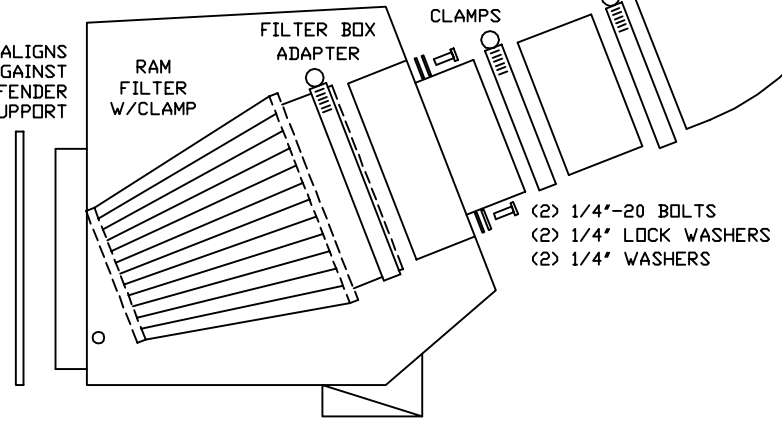



**READ INSTRUCTIONS THOROUGHLY BEFORE DISASSEMBLING.
DO NOT SKIP ANY STEPS.**

INSTALLATION INSTRUCTIONS PART NO. 15966

Installation Instructions:

1. Disconnect the negative battery cables.
2. Remove the screws holding the MAF sensor into the factory air duct.
3. Loosen the clamp holding the airduct to the air box and the clamp holding the duct to the turbo inlet.
4. Remove the factory air duct.
5. Pull up on the factory air box to remove it.
6. Remove the factory air box mounting tray.
7. If there is a silver mat pressed onto the fenderwell remove it now.
8. Install the volant box into factory position using the hardware provided.
9. Attach the 4.5 x 3.5 sleeve onto the filter adapter and tighten with a #72 clamp.
10. Attach the 3.75 x 4.25 sleeve onto the turbo inlet and tighten with a #64 clamp.
11. Press the Volant air duct into the sleeves and tighten the remaining clamps
12. Attach the MAF with the volant gasket and tighten with the hardware provided.
13. Attach the filter to the filter adapter and tighten the clamp.
14. Install the volant air box lid and re attach the battery cables.

WARNING: OVER TIGHTENING HARDWARE MAY ALTAR THE INTEGRITY OF THE VOLANT AIR INTAKE SYSTEM.

BEFORE ROAD TESTING

1. Start engine, leaving the transmission in park and securing the parking brake.
2. Make sure to look and listen for any unusual noises or air leaks. Repair problems if needed.
3. Once completed it will be necessary to check periodically for realignment and tightening of all connections.
4. Once all tests are completed, enjoy the performance of your new Air Intake System.

CARE AND CLEANING

Check the cotton reusable filter periodically and remove any excessive dirt build-up by tapping the filter on the ground and brushing off the loosened dirt. Clean the filter by using Volant's Filter Recharger Kit. Volant's Filter Recharger Kit is designed to restore original air flow. Re-oil every 10,000 miles without cleaning to improve filtering in sand and dirt. Clean only when dirt is very excessive or 50,000 miles.

RECOMMENDED SERVICE PARTS

RECOMMENDED SERVICE PARTS	PART NO.
POWERCORE FILTER UPGRADE	61517
REPLACEMENT FILTER	5150
PREFILTER	51906
CLEANING KIT	5100

APPLICATION GUIDE

MY	MAKE	MODEL	ENG.
MID 04-05	CHEVROLET	SILVERADO	6.6L
MID 04-05	GMC	SIERRA	6.6L

INSTALL

