

VOLANT COOL AIR INTAKES  
 PART NO.: 158436  
 INSTALLATION INSTRUCTIONS

158436 PARTS LIST		4	#056 CLAMPS
1	FILTER BOX	4	1/4"-20 TRUSS HEAD SCREWS
1	FILTER BOX LID	4	1/4" RUBBER WASHERS
1	FILTER BOX ADAPTER	3	1/4"-20 BOLTS
1	VOLANT AIR DUCT	3	1/4" WASHERS
1	POWERCORE FILTER W/CLAMP	5	1/4" LOCK WASHERS
1	3 1/2" X 3 1/2" SLEEVE	4	1/4" X 7/8" FENDER WASHERS
1	3 3/4" X 3 1/2" SLEEVE	2	6 MM-25 BOLTS

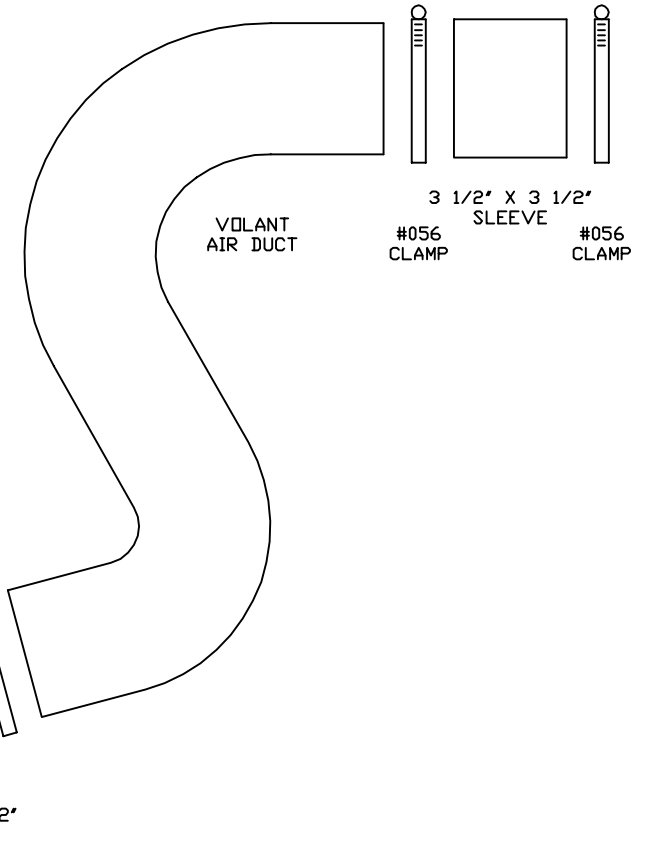

- (4) 1/4"-20 TRUSS HEAD SCREWS
- (4) 1/4" RUBBER WASHERS

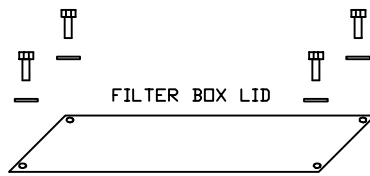

- (3) 1/4"-20 BOLTS
- (3) 1/4" LOCK WASHERS
- (3) 1/4" WASHERS

STOCK RUBBER GROMMET ADAPTER W/CLAMP

#056 CLAMP

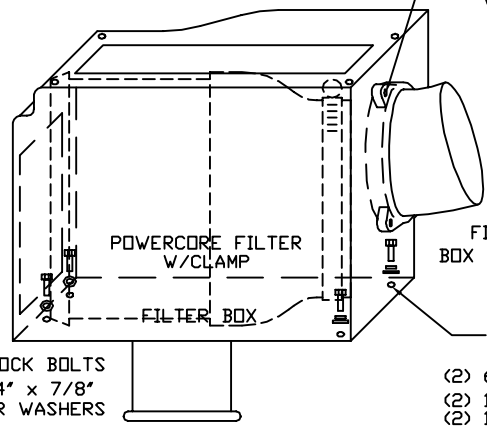

3 3/4" X 3 1/2" SLEEVE

- (2) STOCK BOLTS
- (2) 1/4" x 7/8" FENDER WASHERS

- USE EXISTING STOCK BOLTS TO FASTEN FILTER BOX
- (2) 6 MM-25 BOLTS
- (2) 1/4" LOCK WASHERS
- (2) 1/4" X 7/8" FENDER WASHERS

ACCESSORY FOR SCOOP



**READ INSTRUCTIONS THOROUGHLY BEFORE DISASSEMBLING. DO NOT SKIP ANY STEPS.**

**INSTALLATION INSTRUCTIONS PART NO. 158436**

**Installation Instructions:**

1. Disconnect the negative battery cable.
2. Loosen the hose clamp located on the stock air duct attached to the stock filter box. Pull the stock duct off the mass flow sensor.
3. Loosen the stock rubber grommet hose clamp that connects your mass flow sensor to the stock filter box. Pull the sensor away from the filter box and set the sensor aside. DO NOT disconnect the mass flow sensor.
4. Remove the stock filter box by pulling straight up and away from the stock filter box mounting tray.
5. Remove the mounting tray from the chassis by loosening all 6 MM bolts with a 10 MM socket or wrench.
6. Install the Volant filter box assembly in the preexisting space of the stock filter box and mounting tray. Use the longer two (2) 6 mm stock bolts along with the provided 6 MM-25 bolts, 1/4" lock washers & 1/4" fender washers to fasten the Volant filter box to the chassis.
7. Remove the stock rubber grommet from the stock filter box and relocate it on the Volant filter box adapter. DO NOT tighten the stock rubber grommet hose clamp.
8. Make sure that the arrow on the sensor is pointing towards the throttle body. Insert the mass flow sensor to the stock rubber grommet and tighten the hose clamp. Reconnect the stock air duct to the mass flow sensor located on the Volant air box.
9. Insert the Volant ram filter in the Volant air box. Connect the ram filter to the air box adapter. Secure the ram filter with the filter clamp provided.
10. Cover the Volant air box with the Volant lid. Align the lid openings and fasten all four (4) 1/4"-20 truss head screws with the 1/4" rubber washers. Tighten all four (4) 1/4"-20 truss head screws with a phillips screwdriver.
11. Reattach the negative battery cable.

**WARNING: OVER TIGHTENING HARDWARE MAY ALTAR THE INTEGRITY OF THE VOLANT AIR INTAKE SYSTEM.**

**BEFORE ROAD TESTING**

1. Start engine, leaving the transmission in park and securing the parking brake.
2. Make sure to look and listen for any unusual noises or air leaks. Repair problems if needed.
3. Once completed it will be necessary to check periodically for realignment and tightening of all connections.
4. Once all tests are completed, enjoy the performance of your new Air Intake System.

**CARE AND CLEANING**

Check the cotton reusable filter periodically and remove any excessive dirt build-up by tapping the filter on the ground and brushing off the loosened dirt. Clean the filter by using Volant's Filter Recharger Kit. Volant's Filter Recharger Kit is designed to restore original air flow. Re-oil every 10,000 miles without cleaning to improve filtering in sand and dirt. Clean only when dirt is very excessive or 50,000 miles.

**RECOMMENDED SERVICE PARTS**

RECOMMENDED SERVICE PARTS	PART NO.
POWERCORE FILTER REPLACEMENT	61512
REPLACEMENT COTTON FILTER	5117
PREFILTER	51920

**APPLICATION GUIDE**

MY	MAKE	MODEL	ENG.
99-06	GM	SILVER/SIERRA	4.3L
99-06	CHEVROLET	TAHOE	4.3L

**INSTALL**

