

VOLANT COOL AIR INTAKES
 PART NO.: 150666
 INSTALLATION INSTRUCTIONS

0666 PARTS LIST		4	1/4" RUBBER WASHERS
1	VOLANT FILTER BOX	2	4 MM X 10 SCREWS
1	VOLANT FILTER BOX LID	3	1/4"-20 BOLTS
1	VOLANT AIR DUCT	4	6 MM X 25 BOLTS
1	POWERCORE FILTER W/CLAMP	7	1/4" LOCK WASHERS
2	#072 CLAMPS	7	1/4" WASHERS
1	4 1/2" X 3" HUMP HOSE	1	1/2" X 32" VINYL TRIM
4	1/4"-20 TRUSS HEAD SCREWS	1	SENSOR GASKET

SIDE VIEW

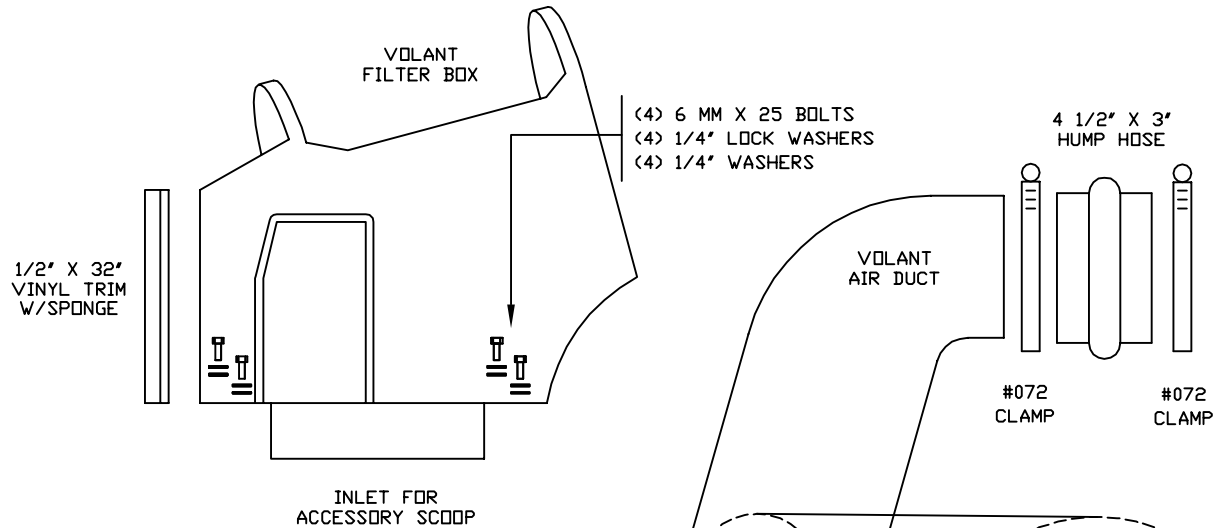

TOP VIEW

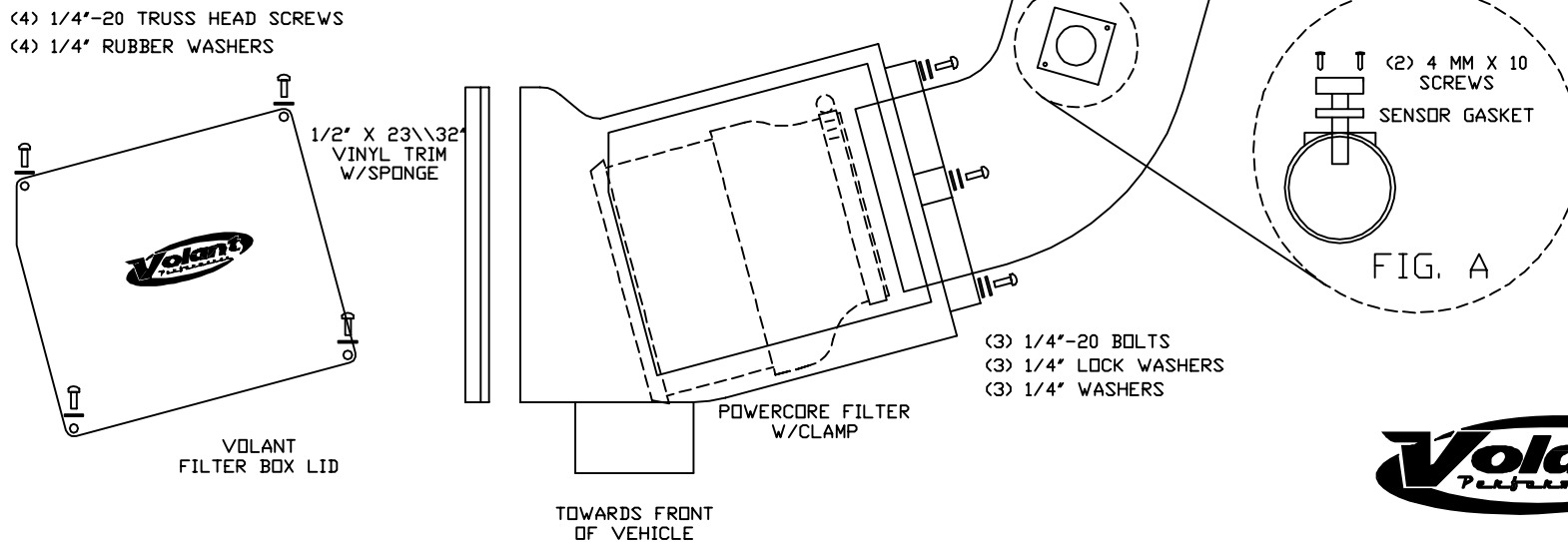



**READ INSTRUCTIONS THOROUGHLY BEFORE DISASSEMBLING.
DO NOT SKIP ANY STEPS.**

INSTALLATION INSTRUCTIONS PART NO. 150666

Installation Instructions:

1. Disconnect the negative battery cables.
2. Loosen the clamp the clamp holding the air duct to the turbo manifold.
3. Remove the two screws holding the MAF sensor into the air duct
4. Pull up on the air box and remove the factory system from the engine compartment
5. Remove the factory mounting tray
6. Remove the plastic plate behind the headlight by pulling stright back to dislodge the 2 tree rivets
7. Place the 32" trim sponge around the volant air box hole where it meets the fender
8. Hand tighten the right rear truss head screw in the back of the volant box making sure the slot in the lid will still slide in
9. Place the volant box into factory position and tighten down with the 6mm hardware provided
10. Attach the 4.5 hump hose to the turbo manifold using a #72 clamp
11. Slide the volant duct into the hump hose and into the volant box, bolt the duct to the air box than tighten the remaining #72 clamp
12. With the filter clamp removed lip the bottom of the filter flange around the air duct and press the filter onto the duct, then fish the clamp around, tighten the filter clamp
13. Attach the volant lid to the filter box
14. Using the gasket provided tighten the MAF to the volant duct
15. Re attach the battery cables

WARNING: OVER TIGHTENING HARDWARE MAY ALTAR THE INTEGRITY OF THE VOLANT AIR INTAKE SYSTEM.

BEFORE ROAD TESTING

1. Start engine, leaving the transmission in park and securing the parking brake.
2. Make sure to look and listen for any unusual noises or air leaks. Repair problems if needed.
3. Once completed it will be necessary to check periodically for realignment and tightening of all connections.
4. Once all tests are completed, enjoy the performance of your new Air Intake System.

CARE AND CLEANING

Check the cotton reusable filter periodically and remove any excessive dirt build-up by tapping the filter on the ground and brushing off the loosened dirt. Clean the filter by using Volant's Filter Recharger Kit. Volant's Filter Recharger Kit is designed to restore original air flow. Re-oil every 10,000 miles without cleaning to improve filtering in sand and dirt. Clean only when dirt is very excessive or 50,000 miles.

RECOMMENDED SERVICE PARTS

RECOMMENDED SERVICE PARTS	PART NO.
POWERCORE FILTER	61558
COTTON FILTER	5158
PREFILTER	551921
CLEANING KIT	N/A
RAM AIR SCOOP	35066

APPLICATION GUIDE

MY	MAKE	MODEL	ENG.
MID 05-07	CHEVROLET	SILVERADO	6.6L

INSTALL

