

VOLANT COOL AIR INTAKES  
 PART NO.: 12740  
 INSTALLATION INSTRUCTIONS

12740 PARTS LIST			
1	VOLANT FILTER BOX	4	#056 CLAMPS
1	VOLANT FILTER BOX LID	3	10/32" X 3/4" BOLTS
1	VOLANT AIR DUCT	1	6 MM X 25 BOLTS
1	VOLANT RAM AIR SCOOP	2	8 MM X 20 BOLTS
1	RAM FILTER W/CLAMP	4	1/4" WASHER
1	3 1/4" X 3" SLEEVE	2	3/8" WASHERS
1	3 1/2" X 3" HUMP HOSE	1	1/4" LOCK WASHER
2	3/8" LOCK WASHERS	5	1/4" TRUSS HEAD SCREWS
5	1/4" RUBBER WASHERS	5	1/4" RUBBER WASHERS
1	5/8" STRAIGHT FITTING	1	5/8" X 3 1/2" BREATHER HOSE
1	5/8" X 3 1/2" BREATHER HOSE	1	18 1/4" VINYL TRIM W/SPONGE
1	18 1/4" VINYL TRIM W/SPONGE	2	SS SELF TAP SCREWS
2	SS SELF TAP SCREWS	1	MASS FLOW SENSOR GASKET
1	MASS FLOW SENSOR GASKET		

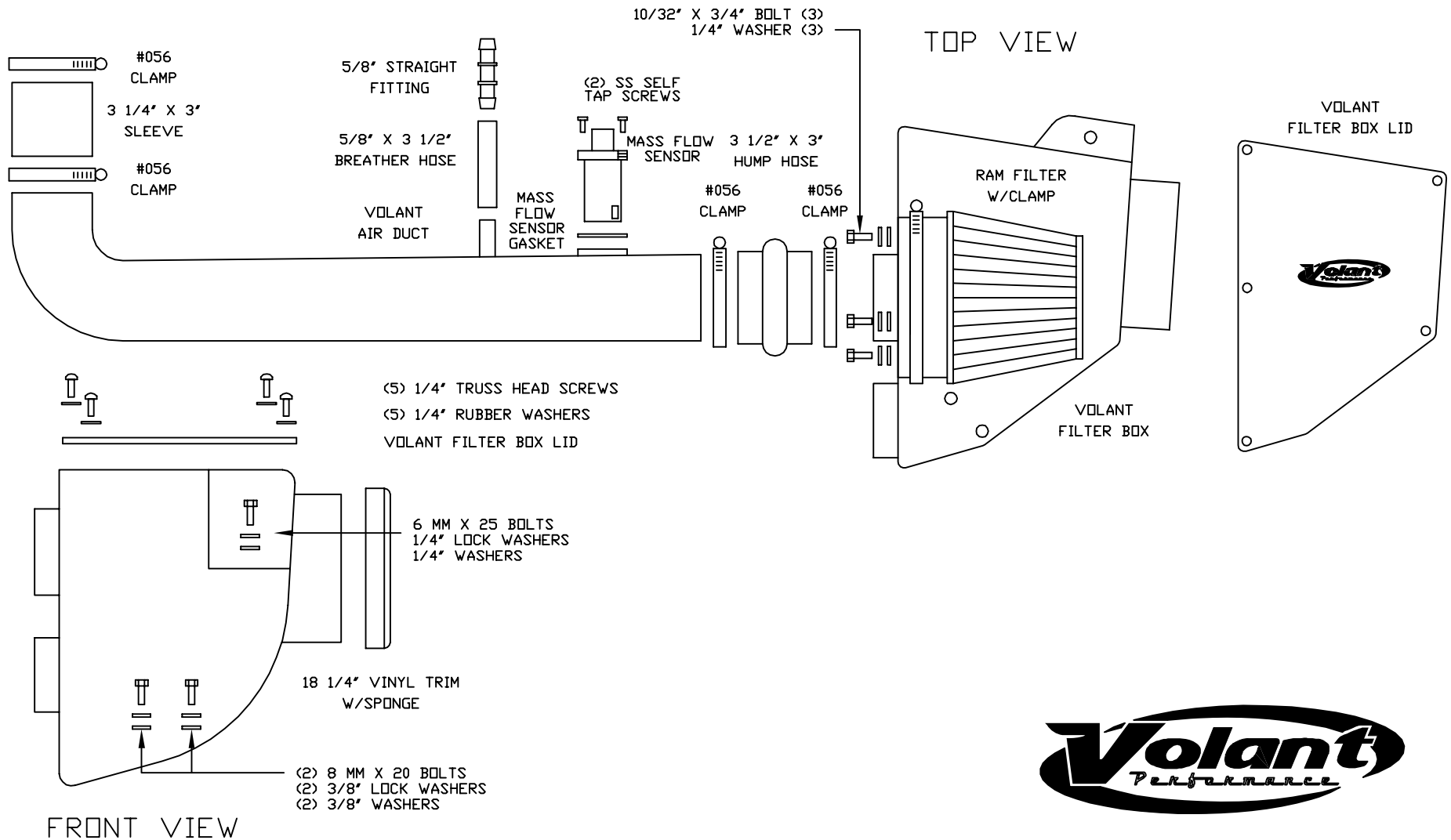



**READ INSTRUCTIONS THOROUGHLY BEFORE DISASSEMBLING. DO NOT SKIP ANY STEPS.**

### INSTALLATION INSTRUCTIONS PART NO. 12740

#### Installation Instructions:

1. Disconnect the negative battery cable.
2. Remove the MAF sensor from the factory duct by removing the two Phillips screws, remove the factory MAF gasket.
3. Remove the two bolts holding the factory engine cover and pull straight up to remove the cover from the engine cover.
4. Remove the two bolts holding the resonator box into place.
5. Using pliers remove the clamp holding the breather hose on the duct pull back to remove the hose.
6. Remove the clamps holding the duct to the throttle body and to the air box then remove the duct from the engine compartment.
7. Remove the rear bolt from the factory air box and remove the box by pulling straight up.
8. Remove the two remaining bolts from the inner fender well.
9. Remove the factory bolt holding the horn bracket to the fender.
10. Attach the 18.25 trim sponge to the volant air box.
11. Place the box into factory position and tighten the volant box down using the provided hardware.
12. For Xterra models attach the volant cap over the ram air inlet
13. Attach the 3.5 hump hose to the filter box adapter using a #56 clamp.
14. Attach the 3.25 sleeve to the throttle body using a #56 clamp.
15. Attach the Volant duct into the hump hose and sleeve and tighten with 2 #56 clamps.
16. Attach the 5/8 x 3.5 hose to the stem on the volant duct than attach the 5/8 straight fitting into the hose, than the factory hose onto the volant fitting.
17. Slide the MAF gasket onto the Factory sensor and tighten the sensor to the air duct.
18. Reinstall the engine cover and negative battery cable.

**WARNING: OVER TIGHTENING HARDWARE MAY ALTAR THE INTEGRITY OF THE VOLANT AIR INTAKE SYSTEM.**

#### BEFORE ROAD TESTING

1. Start engine, leaving the transmission in park and securing the parking brake.
2. Make sure to look and listen for any unusual noises or air leaks. Repair problems if needed.
3. Once completed it will be necessary to check periodically for realignment and tightening of all connections.
4. Once all tests are completed, enjoy the performance of your new Air Intake System.

#### CARE AND CLEANING

Check the cotton reusable filter periodically and remove any excessive dirt build-up by tapping the filter on the ground and brushing off the loosened dirt. Clean the filter by using Volant's Filter Recharger Kit. Volant's Filter Recharger Kit is designed to restore original air flow. Re-oil every 10,000 miles without cleaning to improve filtering in sand and dirt. Clean only when dirt is very excessive or 50,000 miles.

### RECOMMENDED SERVICE PARTS

RECOMMENDED SERVICE PARTS	PART NO.
COTTON FILTER	5120
PREFILTER	51914
CLEANING KIT	5100

### APPLICATION GUIDE

MY	MAKE	MODEL	ENG.
04-07	NISSAN	XTERRA	4.0L

### INSTALL

