

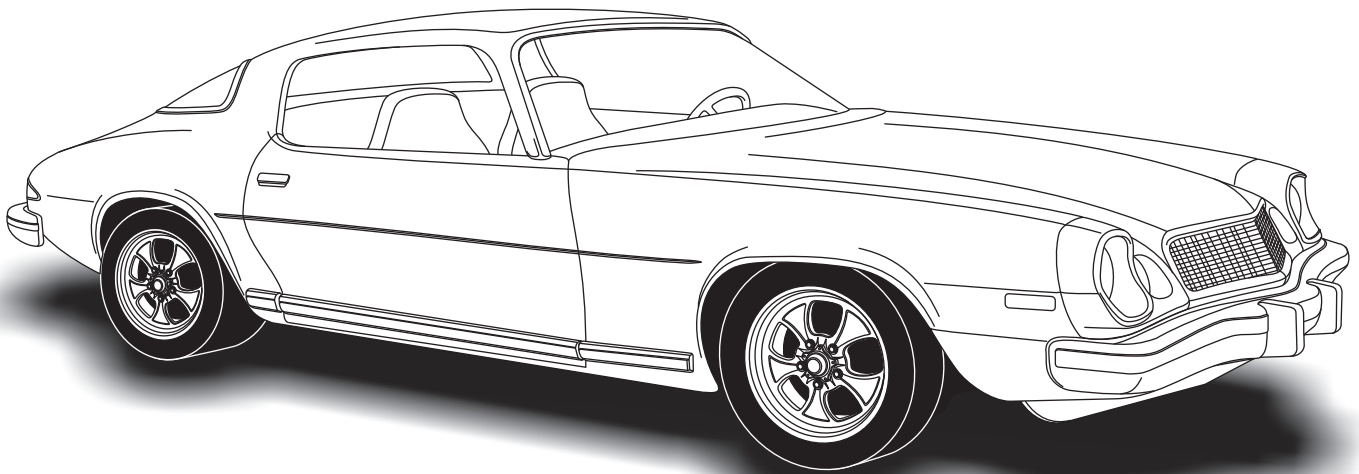

1970-78 Camaro

without Factory Air

561173





Packing List Evaporator Kit (561173)

No.	Qty.	Part No.	Description
1.	1	744004-VUE	4-Vent Evaporator Sub Case w/ 204 ECU
2.	1	781178	Accessory Kit 1970-78 Camaro wo A/C

**** Before beginning installation, open all packages and check contents of shipment. Please report any shortages directly to Vintage Air within 15 days. After 15 days, Vintage Air will not be responsible for missing or damaged items.**

①

**4-Vent Evaporator
Sub Case w/ 204 ECU
744004-VUE**

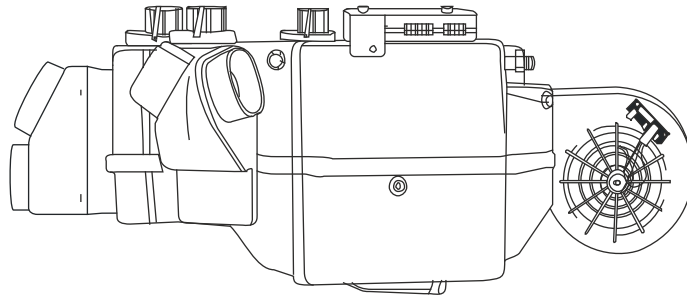

②

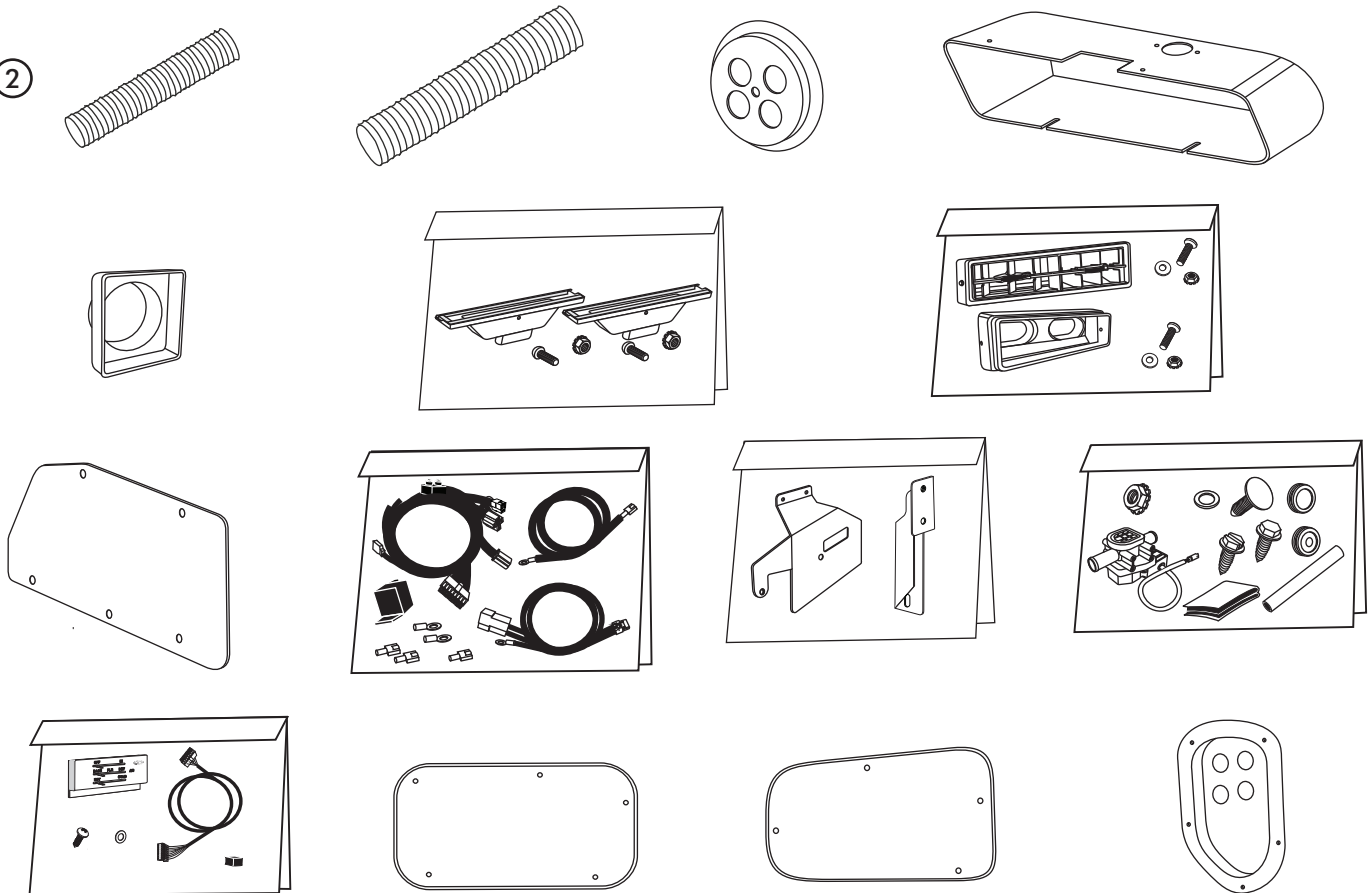

**Accessory Kit
781178**

**NOTE: Images may not depict actual parts and quantities.
Refer to packing list for actual parts and quantities.**



Important Notice—Please Read

For Maximum System Performance, Vintage Air Recommends the Following:

NOTE: Vintage Air systems are designed to operate with R134a refrigerant only. Use of any other refrigerant could damage your A/C system and/or vehicle, and possibly cause a fire, in addition to potentially voiding the warranties of the A/C system and its components.

Refrigerant Capacities:

Vintage Air System: 1.8 lbs. (1 lb., 12 oz.) of **R134a**, charged by weight with a quality charging station or scale. **NOTE:** Use of the proper type and amount of refrigerant is critical to system operation and performance.

Other Systems: Consult manufacturer's guidelines.

Lubricant Capacities:

New Vintage Air-supplied Sanden Compressor: No additional oil needed (Compressor is shipped with proper oil charge).

All Other Compressors: Consult manufacturer (Some compressors are shipped dry and will need oil added).

Safety Switches

Your Vintage Air system is equipped with a binary pressure safety switch. A binary switch disengages the compressor clutch in cases of extreme low pressure conditions (Refrigerant Loss) or excessively high head pressure (406 PSI) to prevent compressor damage or hose rupture. A trinary switch combines Hi/Lo pressure protection with an electric fan operation signal at 254 PSI, and should be substituted for use with electric fans. Compressor safety switches are extremely important since an A/C system relies on refrigerant to circulate lubricant.

Service Info:

Protect Your Investment: Prior to assembly, it is critical that the compressor, evaporator, A/C hoses and fittings, hardlines, condenser and receiver/drier remained capped. Removing caps prior to assembly will allow moisture, insects and debris into the components, possibly leading to reduced performance and/or premature failure of your A/C system. This is especially important with the receiver/drier.

Additionally, when caps are removed for assembly, **BE CAREFUL!** Some components are shipped under pressure with dry nitrogen.

Evacuate the System for 35-45 Minutes: Ensure that system components (Drier, compressor, evaporator and condenser) are at a temperature of at least 85° F. On a cool day, the components can be heated with a heat gun **or** by running the engine with the heater on before evacuating. Leak check and charge to specifications.

Bolts Passing Through Cowl and/or Firewall:

To ensure a watertight seal between the passenger compartment and the vehicle exterior, for all bolts passing through the cowl and/or firewall, Vintage Air recommends coating the threads with silicone prior to installation.

Heater Hose (Not Included With This Kit):

Heater hose may be purchased from Vintage Air (Part# 31800-VUD) or your local parts retailer. Routing and required length will vary based on installer preference.



Important Wiring Notice—Please Read

Some Vehicles May Have Had Some or All of Their Radio Interference Capacitors Removed. There Should Be a Capacitor Found At Each of the Following Locations:

- 1. On the positive terminal of the ignition coil.**
- 2. If there is a generator, on the armature terminal of the generator.**
- 3. If there is a generator, on the battery terminal of the voltage regulator.**

Most alternators have a capacitor installed internally to eliminate what is called “whining” as the engine is revved. If whining is heard in the radio, or just to be extra cautious, a radio interference capacitor can be added to the battery terminal of the alternator.

It is also important that the battery lead is in good shape and that the ground leads are not compromised. There should be a heavy ground from the battery to the engine block, and additional grounds to the body and chassis.

If these precautions are not observed, it is possible for voltage spikes to be present on the battery leads. These spikes come from ignition systems, charging systems, and from switching some of the vehicle’s other systems on and off. Modern computer-operated equipment can be sensitive to voltage spikes on the power leads, which can cause unexpected resets, strange behavior, and/or permanent damage.

Vintage Air strives to harden our products against these types of electrical noise, but there is a point where a vehicle’s electrical system can be degraded so much that nothing can help.

Radio interference capacitors should be available at most auto and truck parts suppliers. They typically are cylindrical in shape, a little over an inch long, a little over a half inch in diameter, and they have a single lead coming from one end of the cylinder with a terminal on the end of the wire, as well as a mounting clip which is screwed into a good ground on the vehicle. The specific value of the capacitance is not too significant in comparison to ignition capacitors that are matched with the coil to reduce pitting of the points.

- Care must be taken, when installing the compressor lead, not to short it to ground. The compressor lead must not be connected to a condenser fan or to any other auxiliary device. Shorting to ground or connecting to a condenser fan or any other auxiliary device may damage wiring, the compressor relay, and/or cause a malfunction.
- When installing ground leads on Gen IV systems, the blower control ground and ECU ground must be connected directly to the negative battery post.
- For proper system operation, the heater control valve must be connected to the ECU.



Engine Compartment

Before starting the installation, check the function of the vehicle (horn, lights, etc.) for proper operation. Study the instructions, illustrations & diagrams.

Remove the Following:

1. Battery and battery tray (retain) (See Figure 1, below).
2. Drain radiator.
3. Hood latch assembly (retain) including hood latch support.
4. Heater blower motor assembly (discard). To remove the heater blower motor assembly (under hood) and the air distribution system (under dash), remove inner fender (See Figure 3, below).
5. OEM heater hoses (discard) (See Figure 1, below).
6. Remove OEM heater wiring/vacuum harness molded grommet (See Figure 1, below).

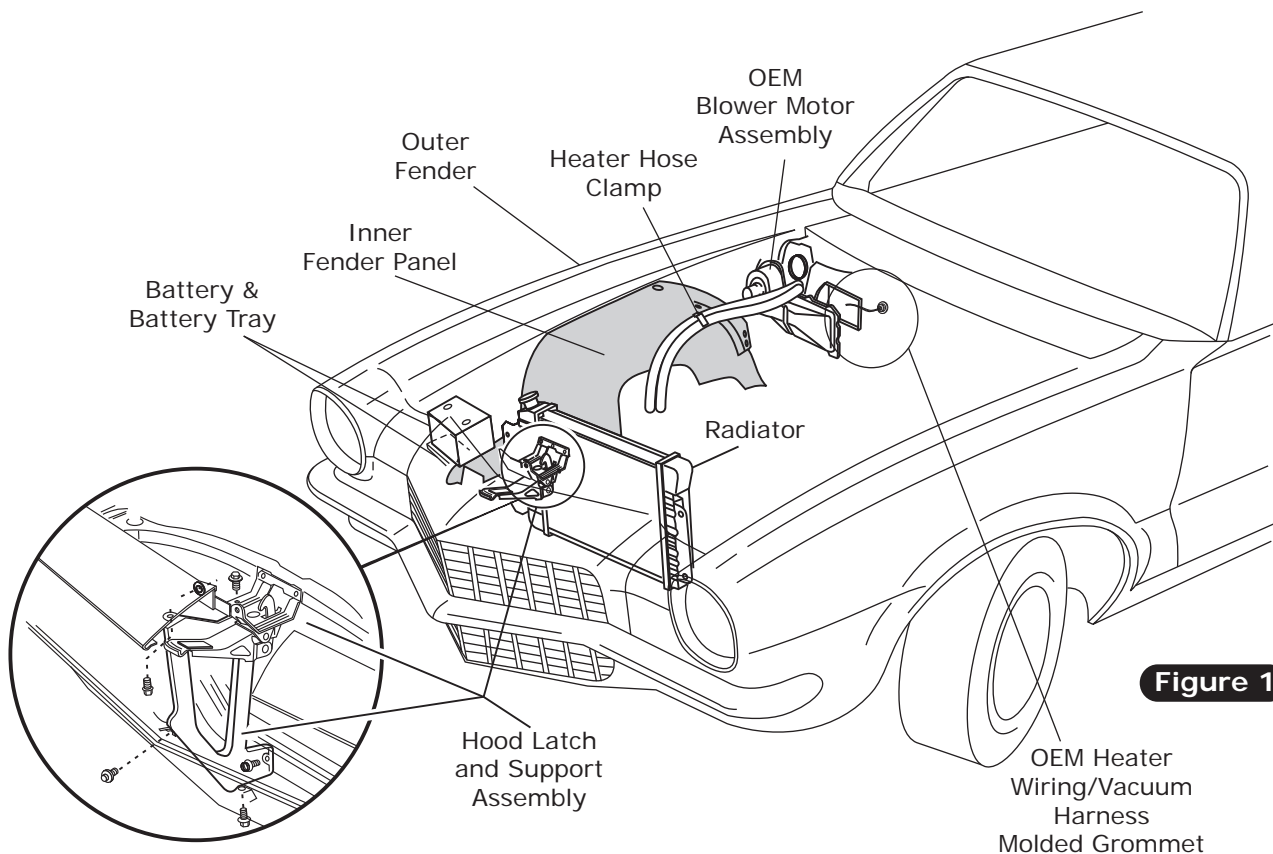

Condenser Assembly & Installation

1. Refer to separate instructions included with the condenser kit to install the condenser.
2. Binary switch installation (refer to condenser instructions).

Compressor & Brackets

1. Refer to separate instructions included with the bracket kit to install the compressor bracket.

Pulleys

1. In most instances, the belt lengths will remain the same.



Passenger Compartment

NOTE: Removal of dashboard is not required to install the evaporator. Vintage Air recommends that you utilize the factory service manual when you disassemble and reassemble the dashboard.

Remove the Following:

1. Glove box door (See Figure 3, below).
2. Glove box (discard, retain screws) (See Figure 2, below).
3. Heater assembly and all related ducting (discard, retain screws) (See Figure 3, below).
4. Driver/passenger side louver outlets (retain). Instrument panel must be removed to get to left outlet and control panel (See Figure 3, below).
5. Control panel assembly (discard) (See Figure 3, below). Refer to control panel conversion kit instructions for installation of controls.
6. Remove passenger side kick panel (retain). Disconnect passenger side fresh air cable from panel (See Figure 3, below). Disconnect driver/passenger cable astro-ventilation ducting (discard).
7. Remove OEM defrost duct assembly (discard).

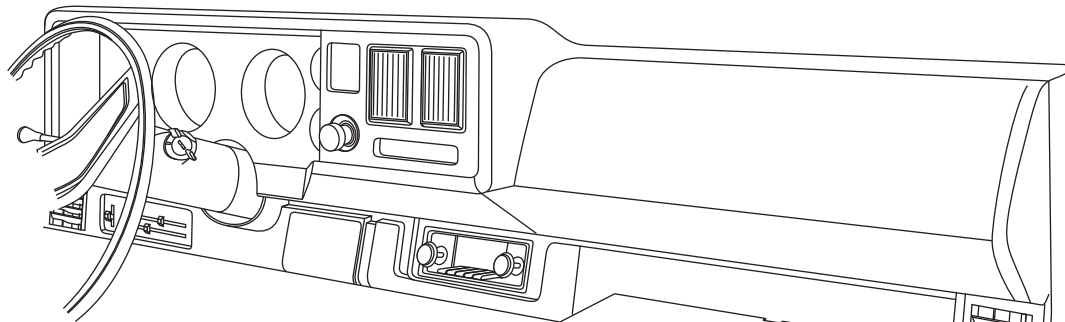

Figure 2

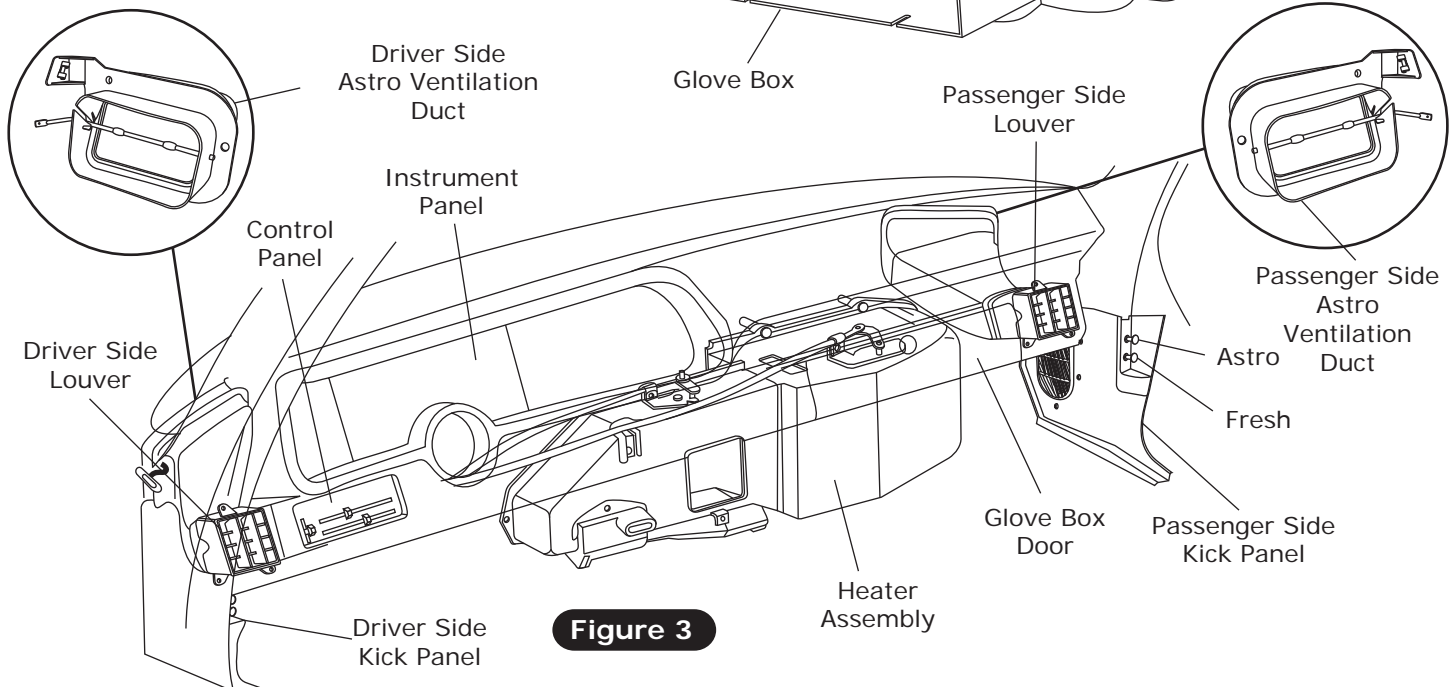

Figure 3



Passenger Side Kick Panel Modification

1. Remove kick panel by removing the (5) OEM screws. Disconnect the fresh air door from the lever housing (See Figure 4, below).
2. Cut kick panel grille using template provided on Page 24 (See Figure 4a, below).
3. Enlarge OEM lever housing holes to 1/2" (See Figure 4a, below).
4. Install (2) 1/2" plastic plugs in OEM lever housing holes (See Figure 4a, below).

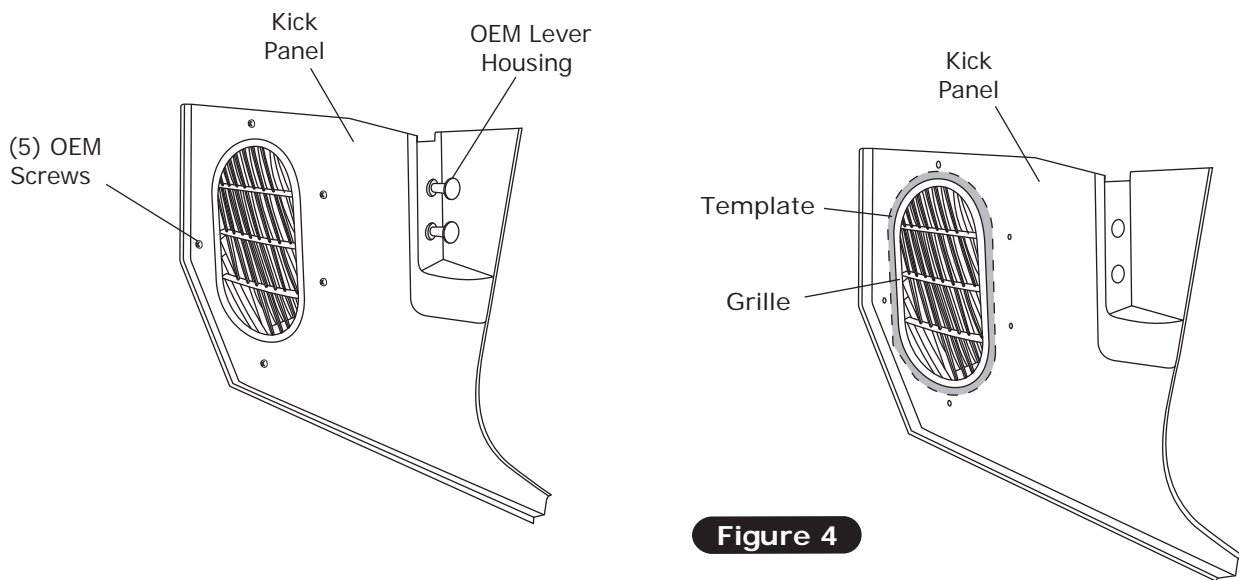

Figure 4

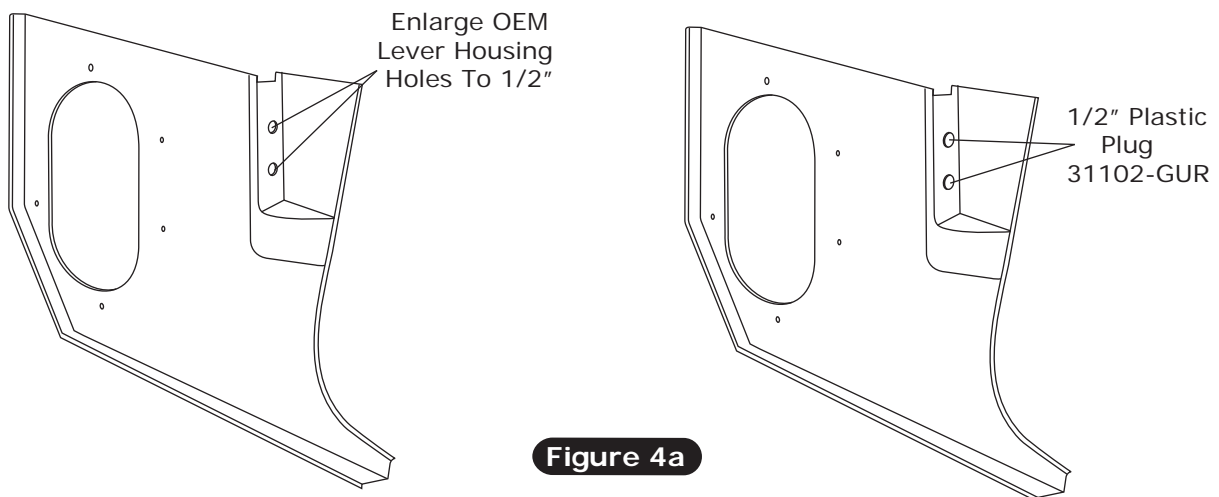
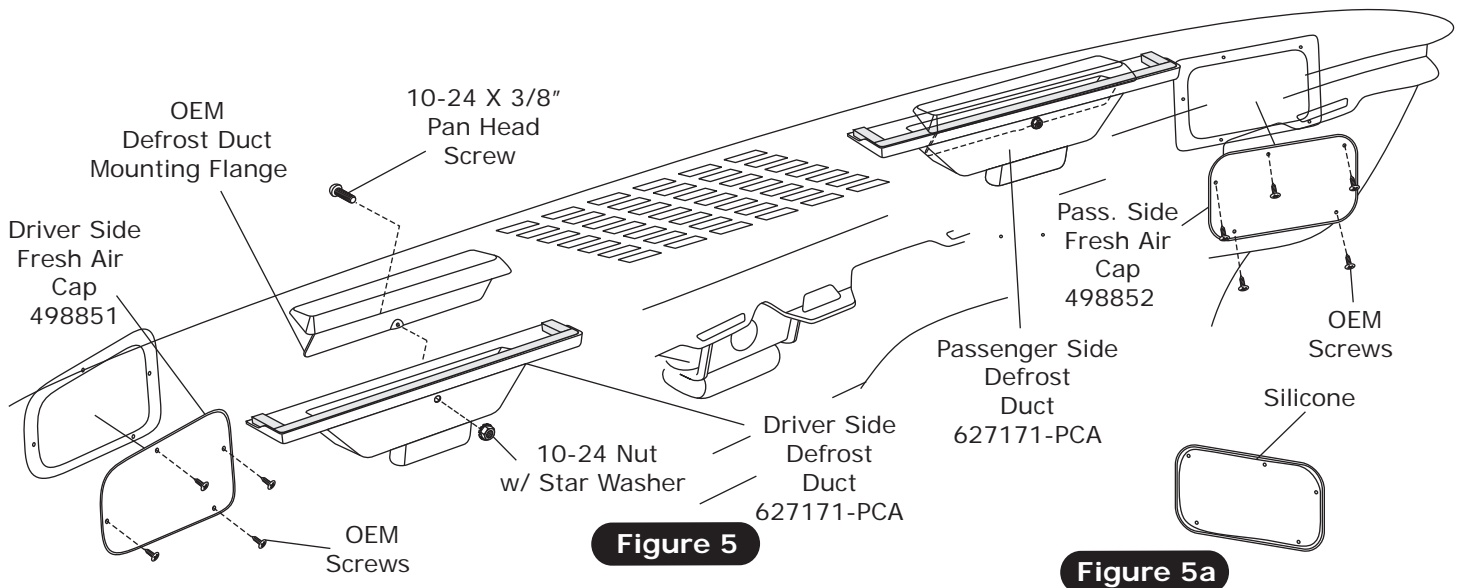

Figure 4a



Defrost Duct/ Fresh Air Cover Installation

1. Install the defrost ducts under dash on OEM defrost duct mounting flange as shown in Figure 5, below. Secure using 10-24 X 3/8" pan head screw and 10-24 nut w/ star washer.
2. Apply a 1/4" bead of silicone around the back side of the driver/passenger side fresh air caps as shown in Figure 5a, below.
3. Install driver/passenger side fresh air caps and secure using OEM screws (See Figure 5, below).



Hose Adapter Installation

1. Install (2) S-clips on hose adapter as shown in Figure 6, below.
2. Install driver & passenger side hose adapters on OEM louvers (See Figure 6, below).

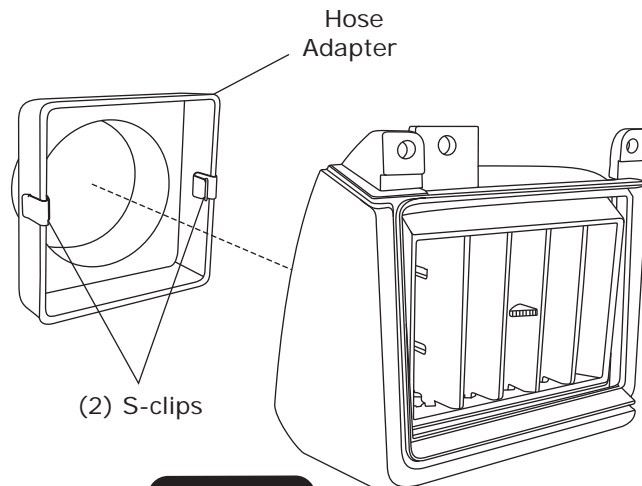

Figure 6



Fresh Air Cover and Heater Cover Bracket Installation

1. Install (4) grommets in fresh air cap (See Figure 7, below).
2. Apply a 1/4" bead of silicone around the back side of the fresh air cap as shown in Figure 7, below.
3. Attach fresh air cap to firewall using a 1/4-20 x 1 1/2" bolt and washer, see Figure 7, below. **NOTE: Fresh air cap installs on engine side of firewall.**
4. Install 1 1/4" plug in firewall (See Figure 7, below).

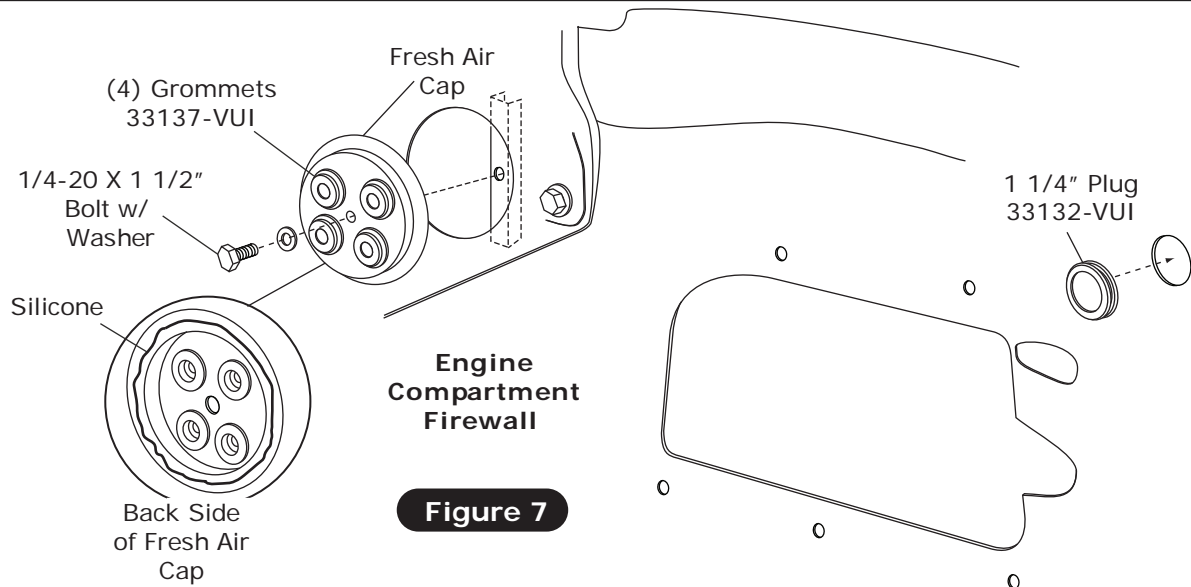

Figure 7

Kick Panel Fresh Air Cap Installation

1. Install (4) grommets in kick panel fresh air cap (See Figure 8a, below).
2. Route A/C and heater hose through fresh air cap and kick panel fresh air cap as shown in Figures 8 and 8b, below.
3. Apply a 1/4" bead of silicone around the back side of kick panel fresh air cap as shown in Figure 8a, below.
4. Secure kick panel fresh air cap using OEM screws as shown in Figure 8b, below.

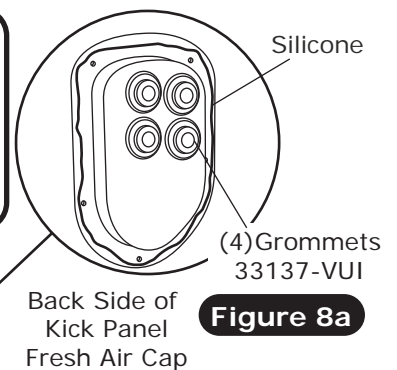

Figure 8a

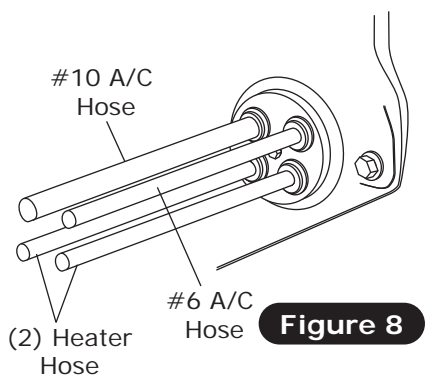

Figure 8

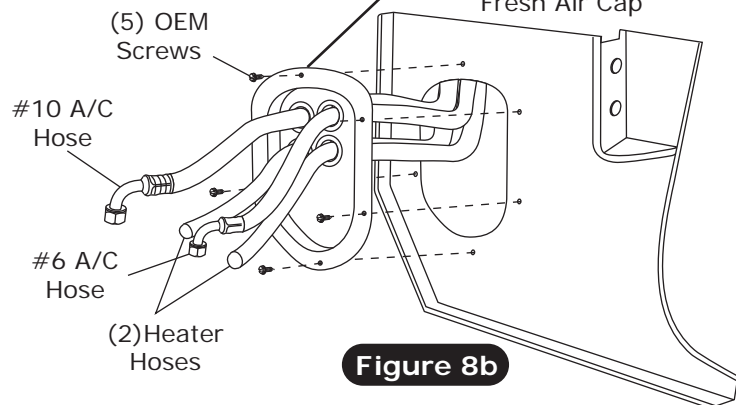

Figure 8b



Evaporator Bracket and Heater Fittings Installation (Cont.)

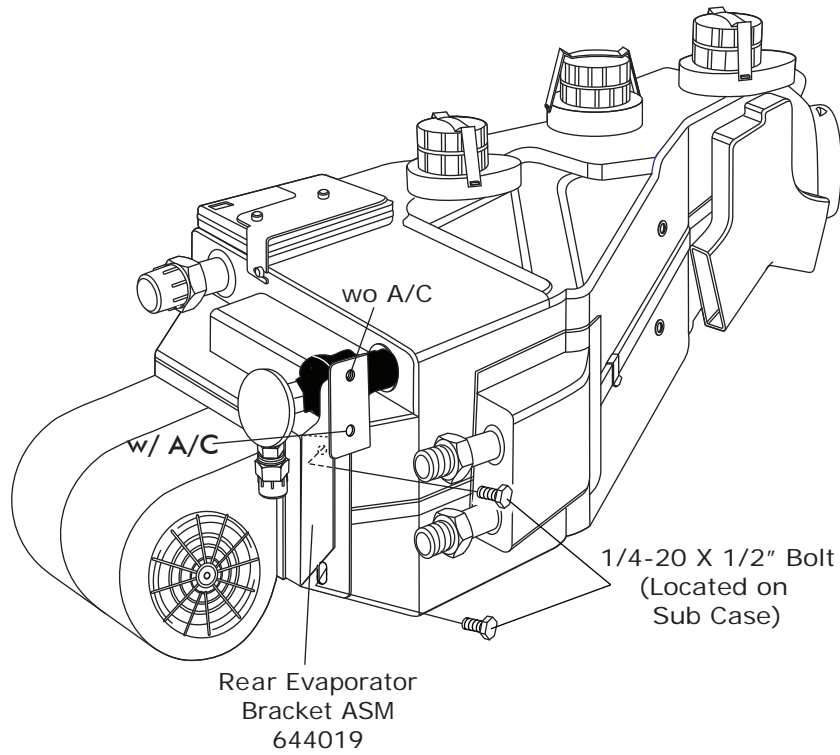
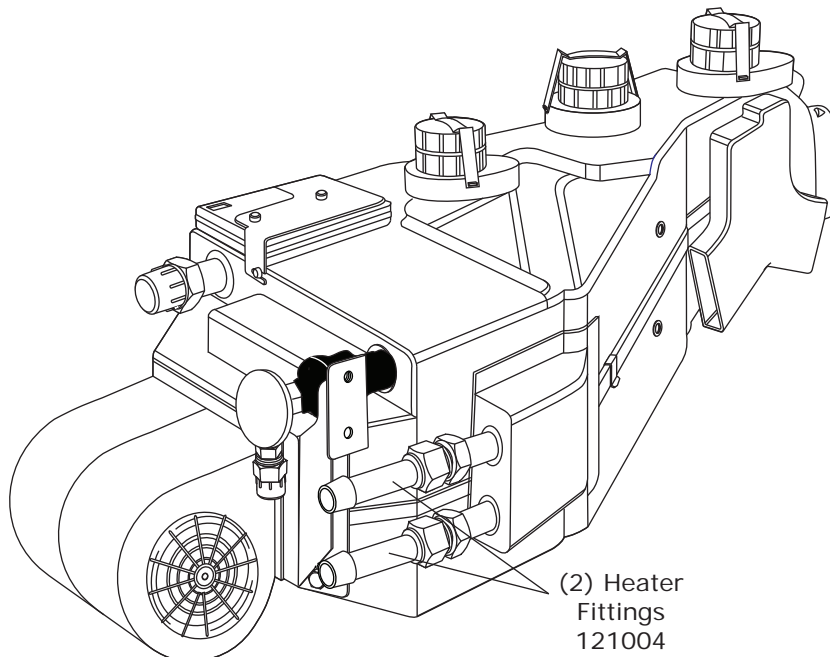

Figure 11





Evaporator Installation

1. Lift evaporator unit up under the dashboard (See Figure 12, below). Secure loosely to the firewall from the engine compartment side using a 1/4-20 x 1" bolt and washer (See Figure 12, below).
2. Using (2) #14 x 3/4" sheet metal screws, secure the front evaporator mounting bracket to the inner cowl (See Figure 12, below).
3. Verify that evaporator unit is level and square to the dash, and then tighten all mounting bolts. **NOTE: Tighten the bolt on firewall first. Then tighten the front mounting bracket screws.**

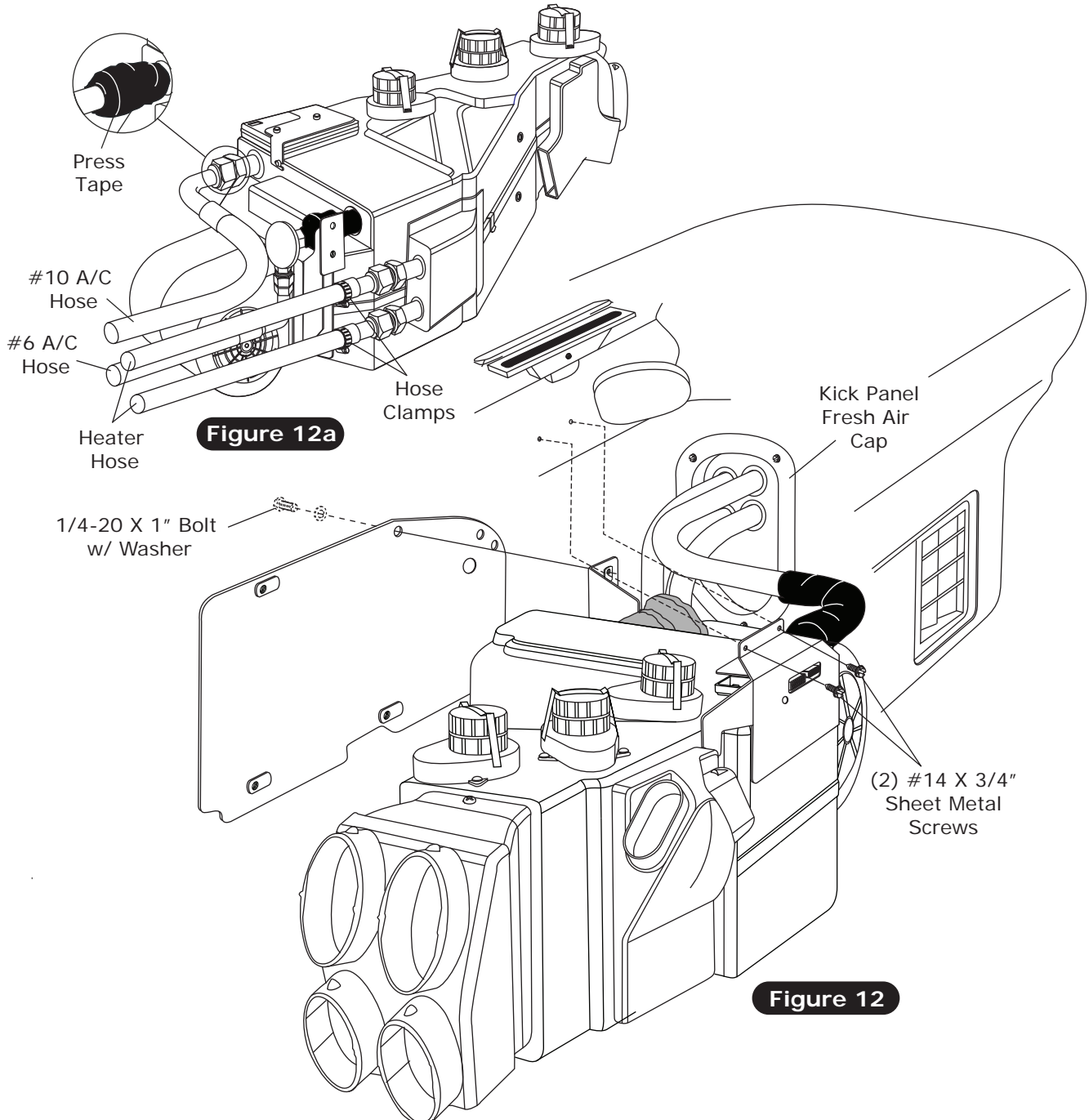



Drain Hose Installation

1. Locate evaporator drain on bottom of evaporator case.
2. In line with the drain, lightly make a mark on the firewall. Measure one inch down and drill a 5/8" hole through the firewall (See Figure 13, below).
3. Install drain hose to bottom of evaporator unit and route through firewall (See Figure 13, below).

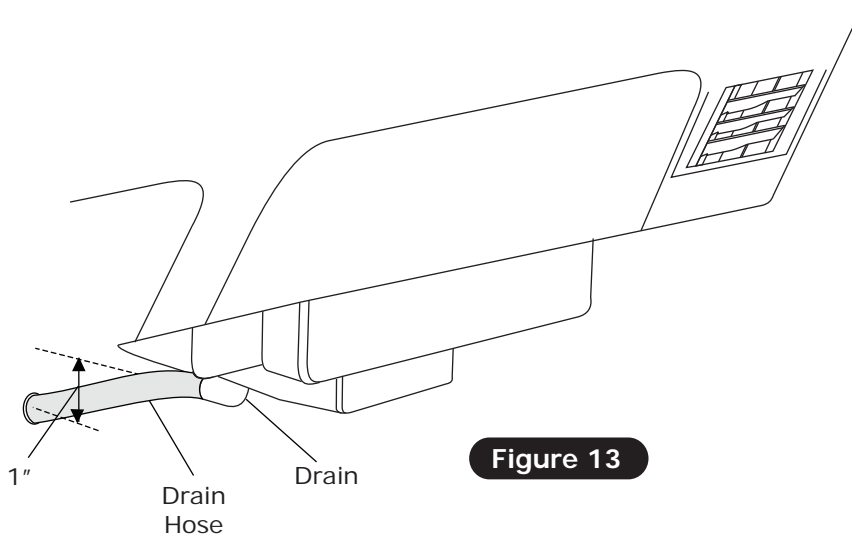

Figure 13

Center Louver Mounting Holes

1. Cut out template provided on Page 27. Slide the template under the dash as shown in Figure 14, below. Align the left and right sides of the template with the crease in the dash as shown in Figures 14 & 14a, below. Align bottom edge of the template along the bottom edge of dash as shown in Figures 14 & 14a, below.
2. Once template is aligned correctly and taped into place, mark mounting holes on dash. Once holes are marked in the correct location, remove template and drill (2) 3/16" holes in dash for the center louver bezel (See Figure 14a, below).

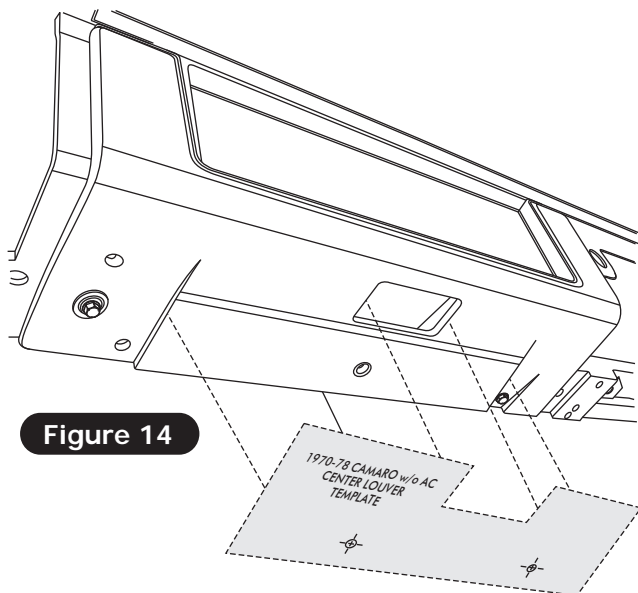

Figure 14

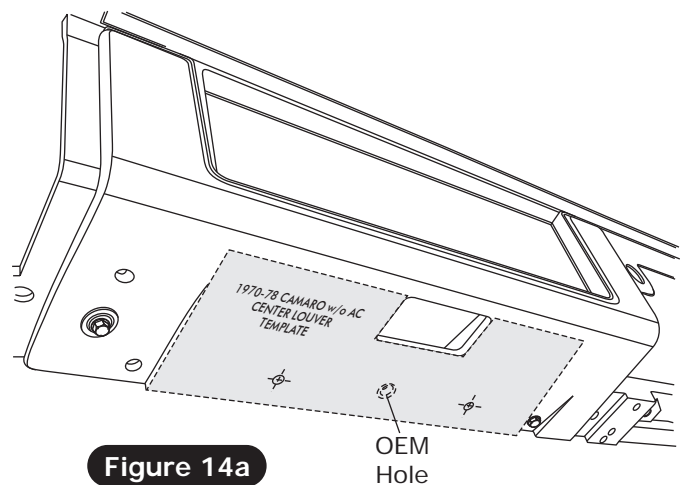

Figure 14a

OEM
Hole



Center Louver Installation

1. Install the center louver bezel under the dash and secure using (2) 10-32 x 3/4" pan head screws w/ washers and 10-32 nuts w/star washers as shown in Figure 15, below.
2. Install the center louver into the bezel as shown in Figure 15, below.
3. Reinstall center console (if equipped) (See Figure 15a, below).

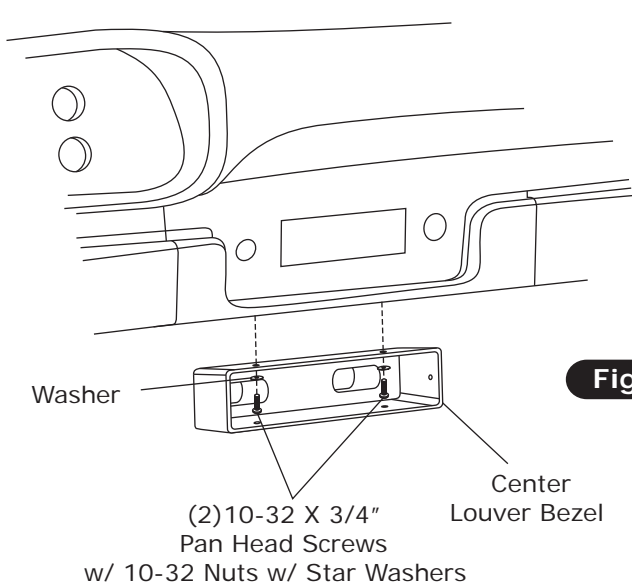

Figure 15

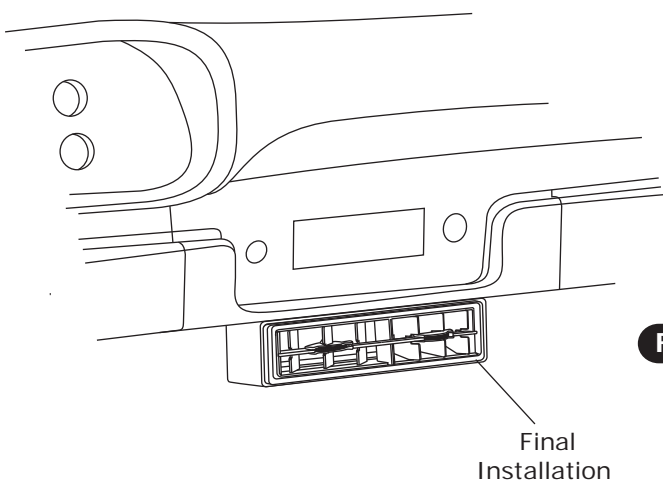
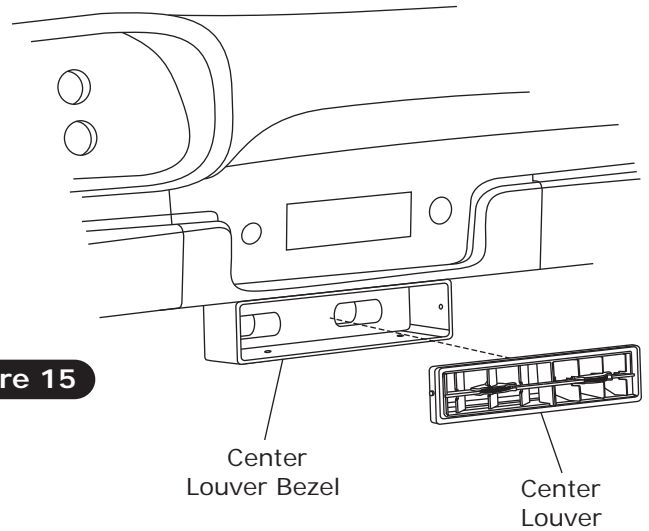
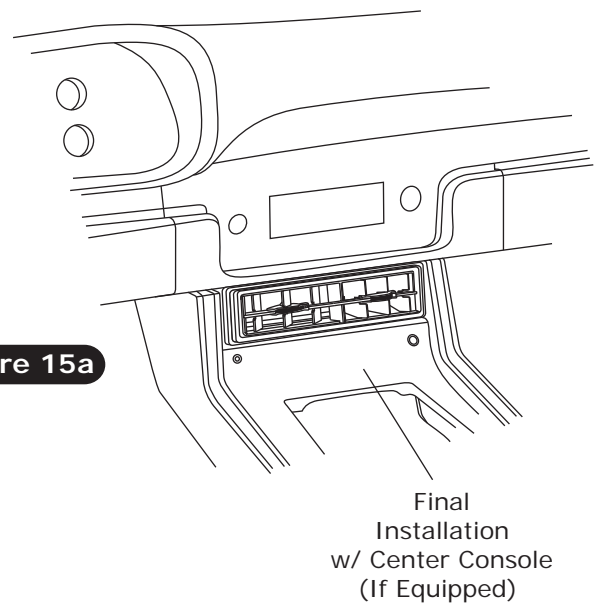
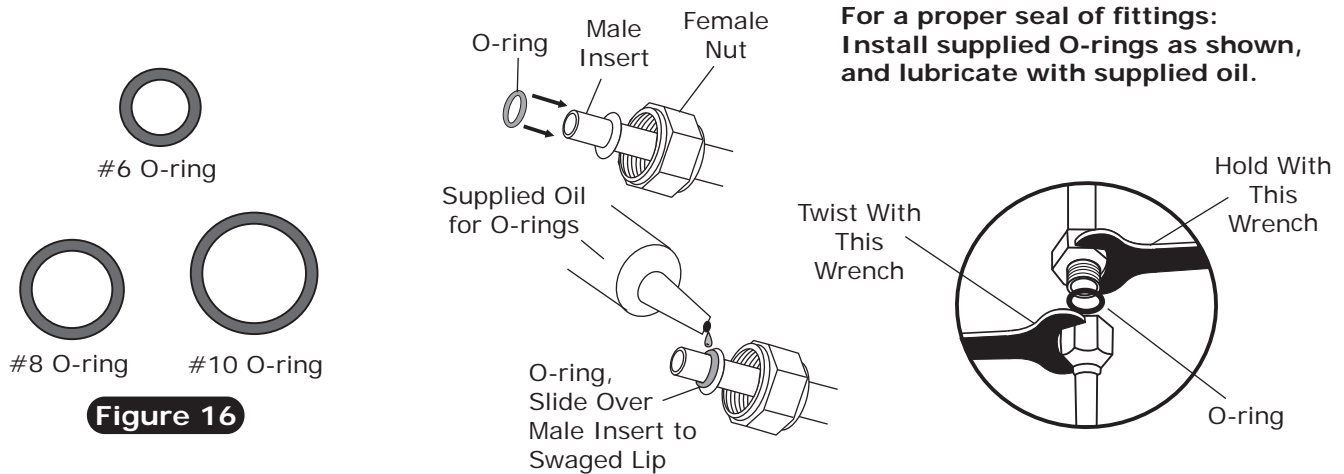

Figure 15a





Lubricating O-rings



1970-73 Camaro Standard Hose Kit

1. Locate the #8 compressor A/C hose. Lubricate (2) #8 O-rings (See Figure 16, above) and connect the 90° female fitting w/ R134a service port to the #8 discharge port on the compressor. Route the 45° female fitting to the #8 condenser hardline coming through the core support (See Figure 17, Page 17). Tighten each fitting connection as shown in Figure 16, above.
2. Locate the #10 compressor A/C hose. Lubricate (2) #10 O-rings (See Figure 16, above) and connect the #10 135° female fitting w/ R134a service port to the #10 suction port on the compressor. Route the 90° female fitting to the #10 evaporator (See Figure 12a, Page 13, and Figure 17, Page 17). Tighten each fitting connection as shown in Figure 16, above.
3. Locate the #6 evaporator A/C hose. Lubricate (2) #6 O-rings (See Figure 16, above) and connect the 45° female fitting to the #6 hardline coming through the core support from the drier. Route the 90° female fitting to the #6 evaporator (See Figure 12a, Page 13, and Figure 17, Page 17). Tighten each fitting connection as shown in Figure 16, above.

1974-78 Camaro Standard Hose Kit

1. Locate the #8 compressor A/C hose. Lubricate (2) #8 O-rings (See Figure 16, above) and connect the 90° female fitting w/ R134a service port to the #8 discharge port on the compressor. Route the 45° female fitting to the #8 condenser hardline coming through the core support (See Figure 18, Page 18). Tighten each fitting connection as shown in Figure 16, above.
2. Locate the #10 compressor A/C hose. Lubricate (2) #10 O-rings (See Figure 16, above) and connect the #10 135° female fitting w/ R134a service port to the #10 suction port on the compressor. Route the 90° female fitting to the #10 evaporator (See Figure 12a, Page 13, and Figure 18, Page 18). Tighten each fitting connection as shown in Figure 16, above.
3. Locate the #6 evaporator A/C hose. Lubricate (2) #6 O-rings (See Figure 16, above) and connect the 90° female fitting to the #6 hardline coming through the core support from the drier. Route the 90° female fitting to the #6 evaporator (See Figure 12a, Page 13, and Figure 18, Page 18). Tighten each fitting connection as shown in Figure 16, above.

Modified A/C Hose Kit

1. Refer to separate instructions included with modified hose kit.



A/C & Heater Hose Routing 1970-73 Camaro

Heater Hose & Heater Control Valve Installation

1. Route a piece of heater hose from the water pump to the top heater fitting of the heater core as shown in Figure 12a, Page 13, and Figure 17, below. Secure using hose clamps.
2. Route a piece of heater hose from the intake to the bottom heater fitting of the heater core as shown in Figure 12a, Page 13, and Figure 17, below. **NOTE: Install heater control valve in line with intake manifold (pressure side) heater hose, and secure using hose clamps as shown in Figure 17, below. Also note proper flow direction.**

NOTE: Vintage Air Systems Require
(2) 5/8 Hose Nipples (Not Supplied)

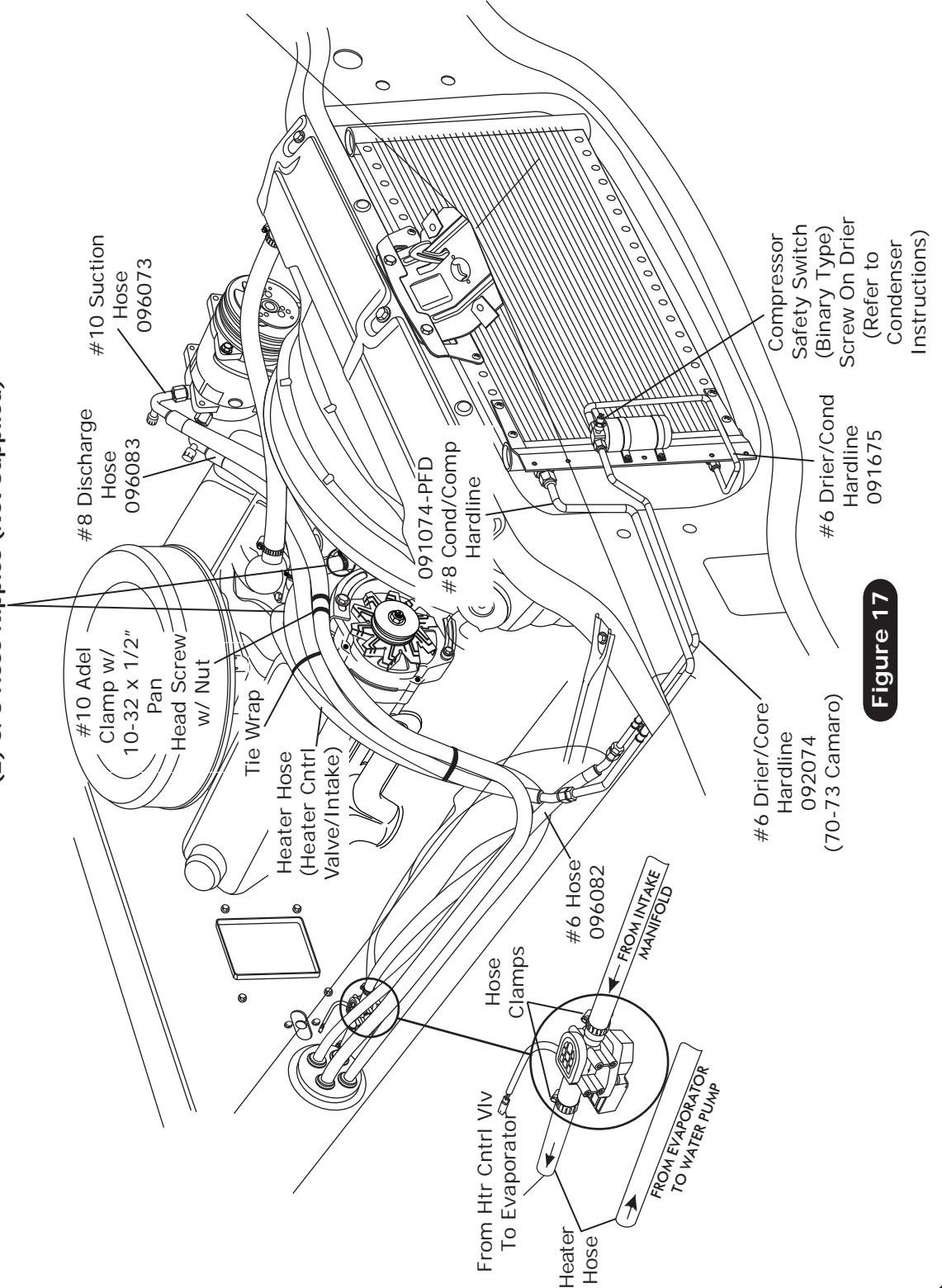



A/C & Heater Hose Routing 1974-78 Camaro (1978 Camaro Shown)

**NOTE: Vintage Air Systems Require
(2) 5/8 Hose Nipples (Not Supplied)**

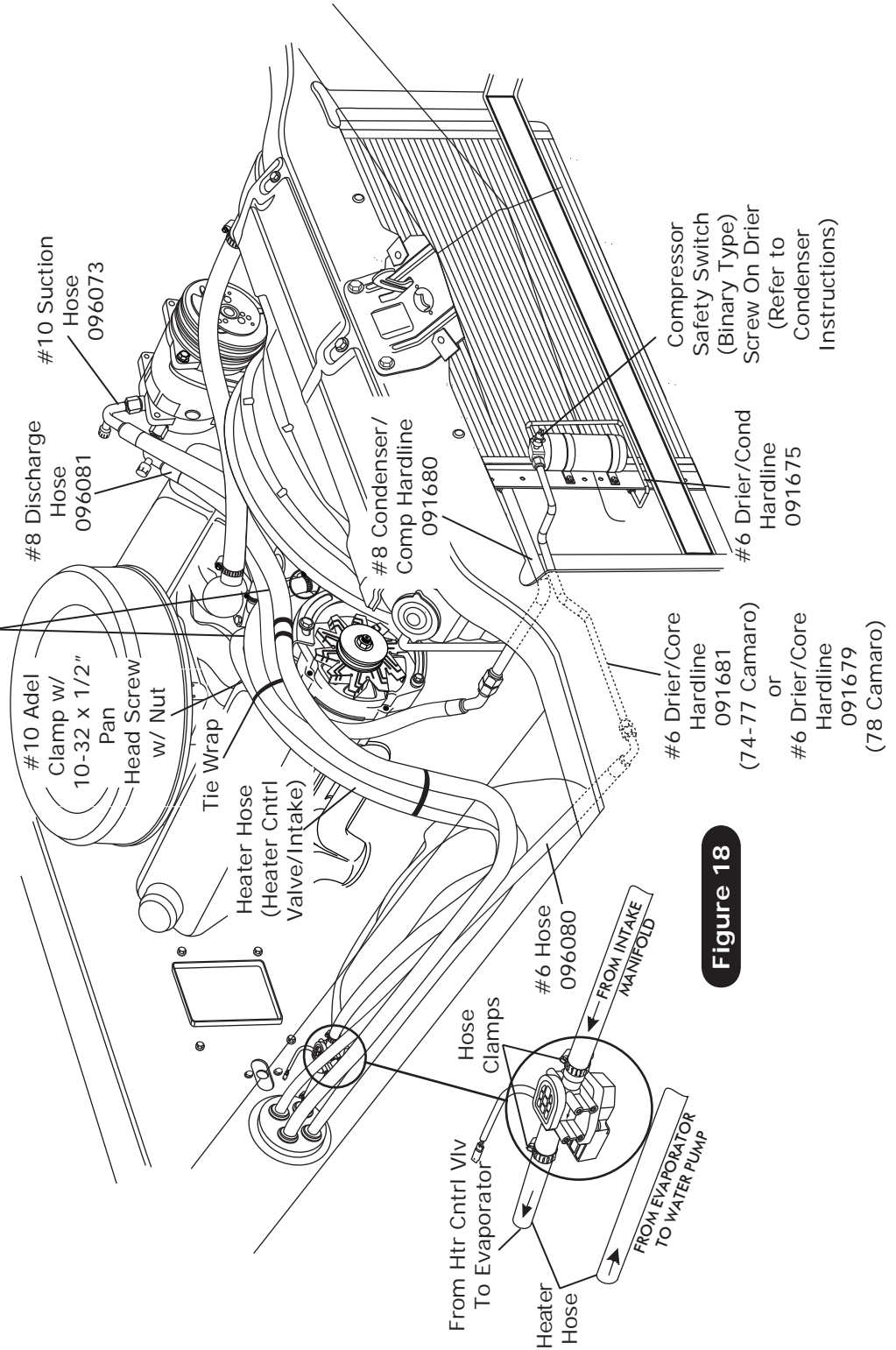

Figure 18

Heater Hose & Heater Control Valve Installation

1. Route a piece of heater hose from the water pump to the top heater fitting of the heater core as shown in Figure 12a, Page 13, and Figure 18, below. Secure using hose clamps.
2. Route a piece of heater hose from the intake to the bottom heater fitting of the heater core as shown in Figure 12a, Page 13, and Figure 18, below. **NOTE: Install heater control valve in line with intake manifold (pressure side) heater hose, and secure using hose clamps as shown in Figure 18, below. Also note proper flow direction.**



Final Steps

1. Install duct hoses as shown in Figure 21, Page 18.
2. Install 3/8" ID grommet (See Figure 19, below).
3. Route A/C wires through 3/8 ID grommet as shown on Figure 19, below (12 volt/ground/binary switch/heater valve).
4. Install control panel assembly.
5. Plug the wiring harness into the ECU module on the sub case as shown in Figure 21, Page 20 (Wire according to wiring diagram on Pages 21 & 22).
6. Install glove box (See Figure 20, below).
7. Reinstall all previously removed items (battery tray & battery).
8. Fill radiator with at least a 50/50 mixture of approved antifreeze and distilled water. It is the owner's responsibility to keep the freeze protection at the proper level for the climate in which the vehicle is operated. Failure to follow antifreeze recommendations will cause heater core to corrode prematurely and possibly burst in A/C mode and/or freezing weather, voiding your warranty.
9. Double check all fittings, brackets and belts for tightness.
10. Vintage Air recommends that all A/C systems be serviced by a certified automotive air conditioning technician.
11. Evacuate the system for a minimum of 45 minutes prior to charging, and leak check prior to servicing.
12. Charge the system to the capacities stated on the information page (Page 4) of this instruction manual.
13. See Operation of Controls procedures on Page 23.

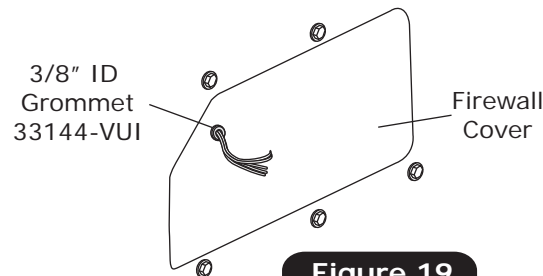

Figure 19

Glove Box Installation

1. Install glove box provided, and secure with OEM screws through OEM holes (See Figure 20, below).
2. Install glove box door.

NOTE: If equipped with the glove box light as shown below in Figure 20a, modify plastic glove box using template provided on Page 25.

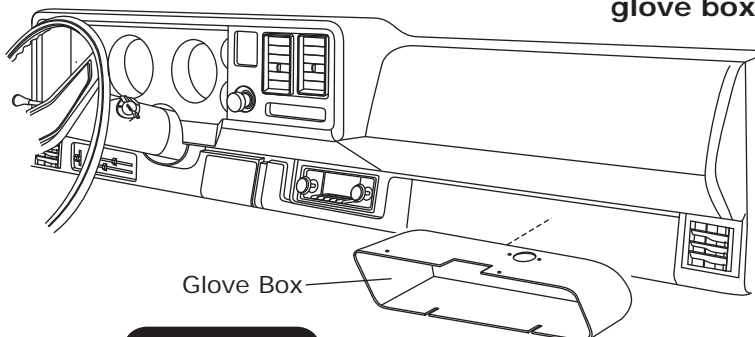

Figure 20

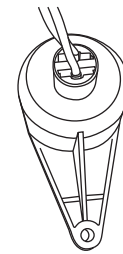

Figure 20a



Control Panel & Duct Hose Routing

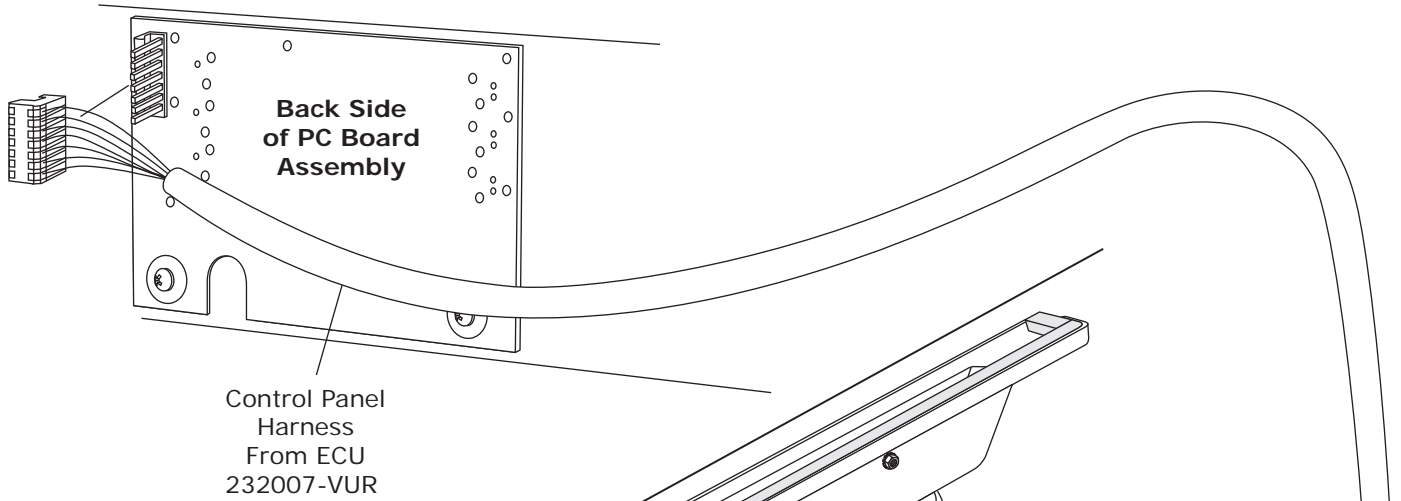
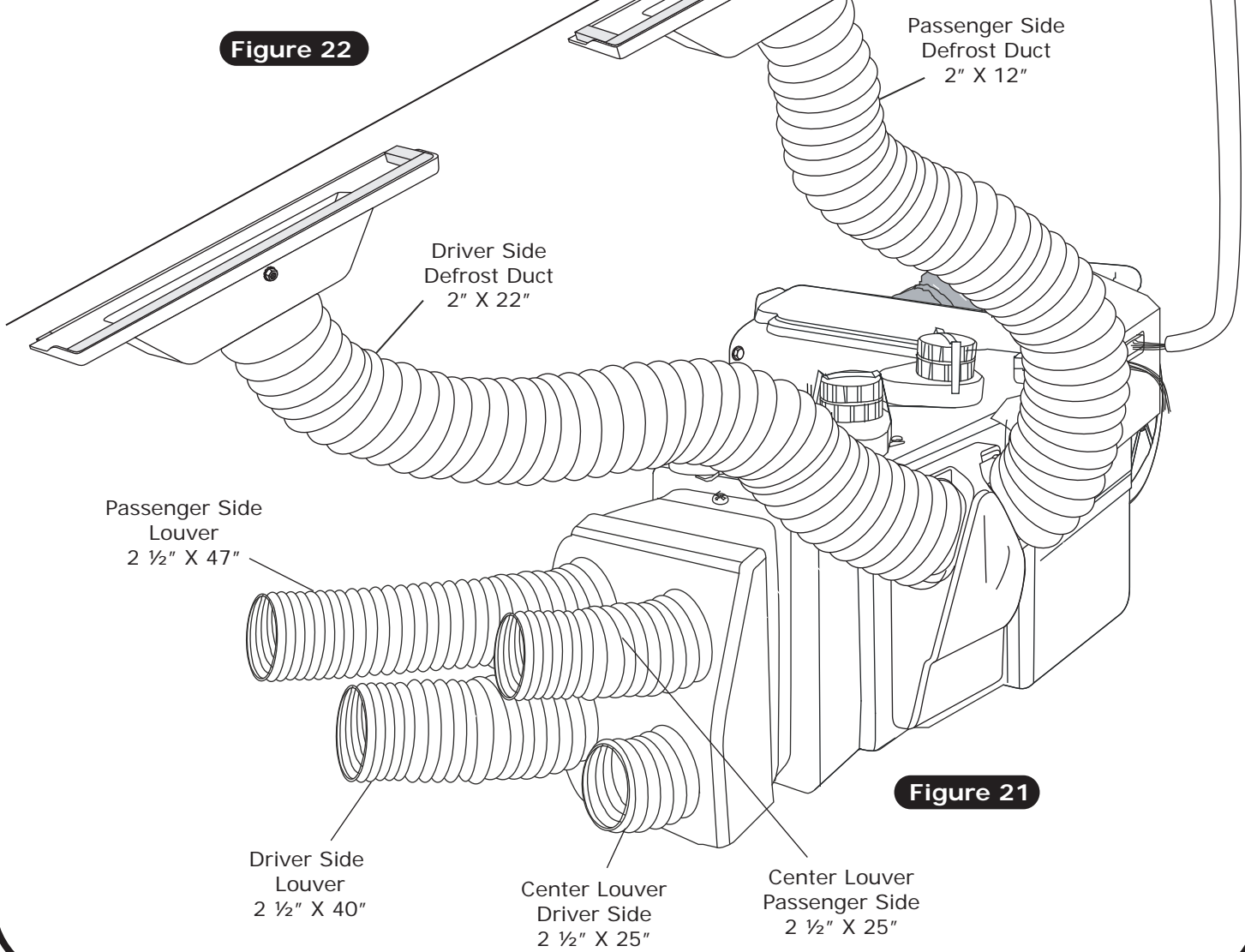

Figure 22





Wiring Diagram

232007-VUR

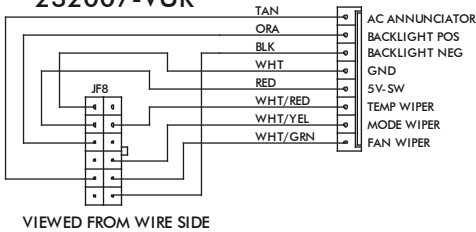

VIEWED FROM WIRE SIDE

232002-VUA

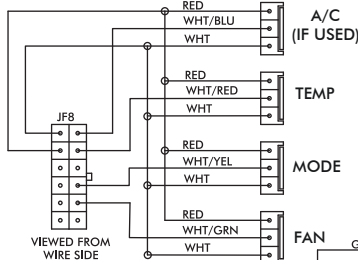

VIEWED FROM WIRE SIDE

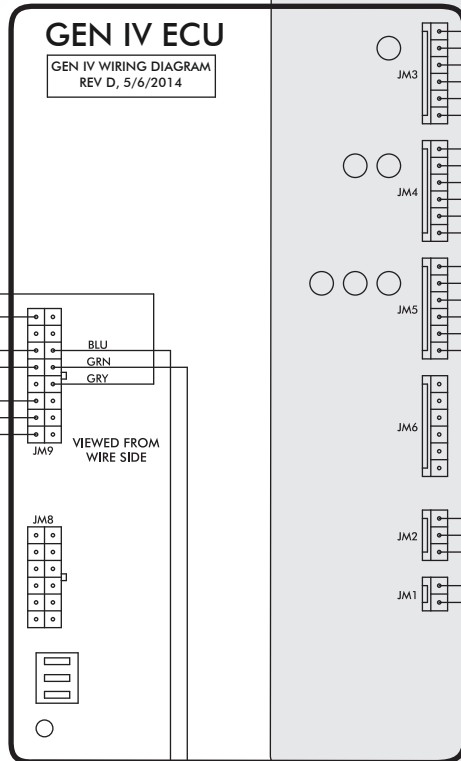

PRE-WIRED

PROGRAM

N/A
* DASH LAMP (IF USED)

*** WIDE OPEN THROTTLE SWITCH (OPTIONAL)

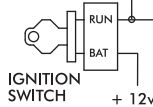

IGNITION SWITCH +12v

** CIRCUIT BREAKER 30 AMP

COMPRESSOR RELAY



BSC

BLOWER MOTOR

HEATER CONTROL VALVE

NOTE: = CHASSIS GROUND

- Dash Lamp Is Used Only With Type 232007-VUR Harness.
- Warning: Always Mount Circuit Breaker As Close to the Battery As Possible. (NOTE: Wire Between Battery and Circuit Breaker Is Unprotected and Should Be Carefully Routed to Avoid a Short Circuit).
- Wide Open Throttle Switch Contacts Close Only at Full Throttle, Which Disables A/C Compressor.



Gen IV Wiring Connection Instruction

WIRING HARNESS

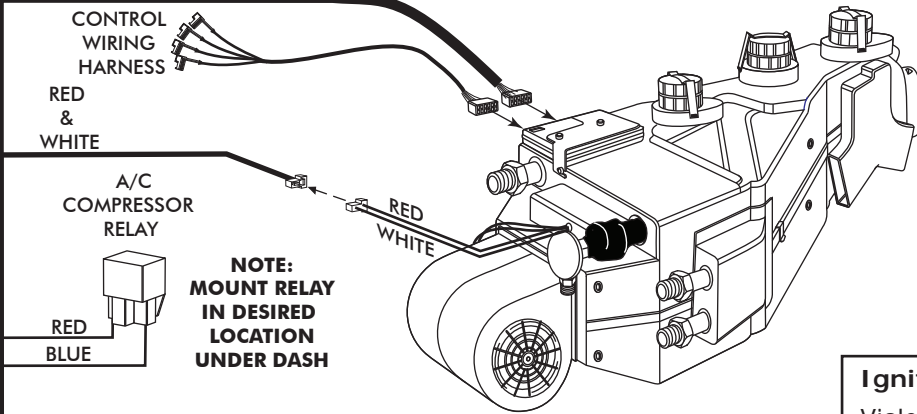

Ignition Switch:
Violet 12V Ign Switch Source (Key On Accessory) Position Must Be Switched.

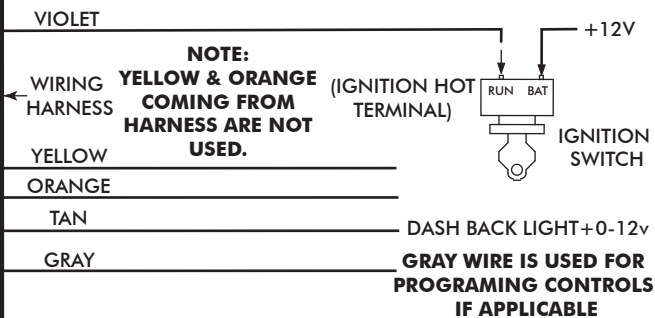

Dash Light:
Tan Wire Used Only With Vintage Air Supplied Control Panel With LED Back Light.

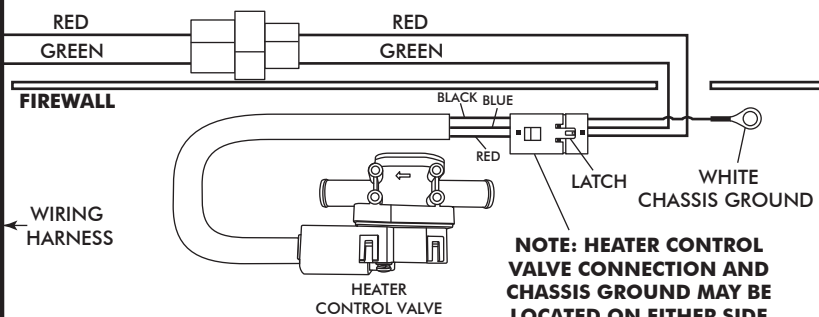

Heater Control Valve:
Install With Servo Motor Facing Down, As Shown. Note Flow Direction Arrow Molded Into Valve Body, And Install Accordingly.

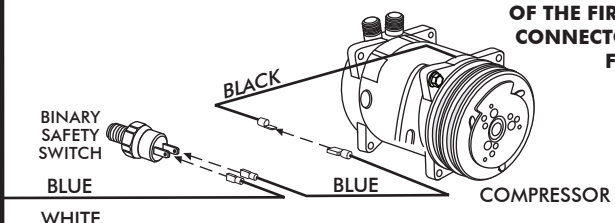

Binary/Trinary & Compressor:
Binary: Connect As Shown (Typical Compressor Wiring). Be Sure Compressor Body Is Grounded.
Trinary Switch: Connect According To Trinary Switch Wiring Diagram.

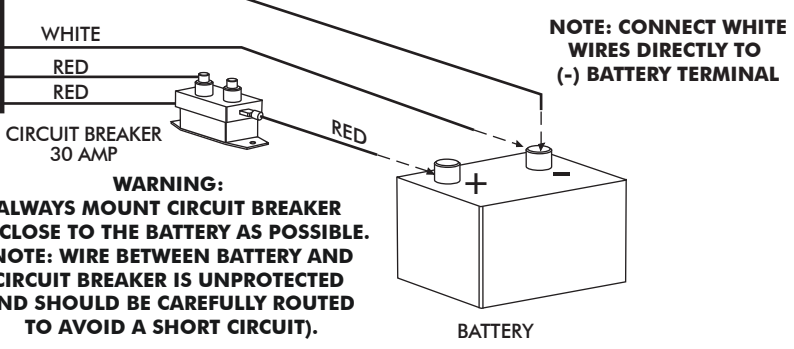

Circuit Breaker/Battery:
White **Must** Run To (-) Battery. Red May Run To (+) Battery Or Starter. Mount Circuit Breaker As Close to Battery As Possible.

WARNING:
ALWAYS MOUNT CIRCUIT BREAKER AS CLOSE TO THE BATTERY AS POSSIBLE. (NOTE: WIRE BETWEEN BATTERY AND CIRCUIT BREAKER IS UNPROTECTED AND SHOULD BE CAREFULLY ROUTED TO AVOID A SHORT CIRCUIT).



Operation of Controls

On Gen IV systems with three lever/knob controls, the temperature control toggles between economy/heat and A/C operations. To activate A/C, move the temperature lever all the way to COLD and then back it off to the desired vent temperature. For economy/heat operation, move the temperature lever all the way to HOT and then adjust to the desired vent temperature. The blower will momentarily change speed each time you toggle between operations to indicate the change.

A/C Operation

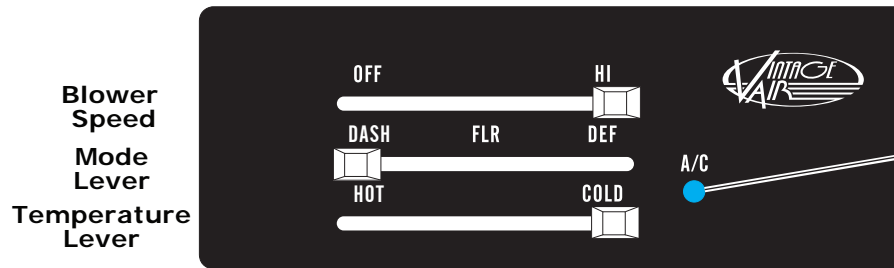

NOTE:
A/C operation toggles on & off when temperature lever is moved to the HOT or COLD ends of travel. A/C mode is indicated by the blue A/C light.

Blower Speed
Adjust to desired speed.

Mode Lever
Slide the lever all the way left for DASH mode.

Temperature Lever
For A/C operation, slide the temperature lever all the way right to engage compressor (Slide lever left or right to adjust to desired temperature).

Heat Operation

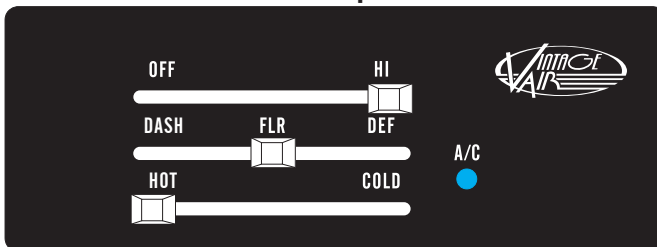

Blower Speed
Adjust to desired speed.

Mode Lever
Slide the lever to the center position for FLR mode.

Temperature Lever
Slide the temperature lever all the way left to the HOT position (Slide lever left or right to desired temperature).

Defrost Operation

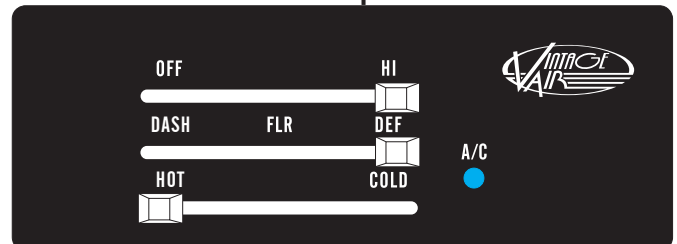

Blower Speed
Adjust to desired speed.

Mode Lever
Slide the lever all the way right for DEF mode.

Temperature Lever
Adjust lever to desired temperature (Compressor is automatically engaged).



Troubleshooting Guide

Symptom	Condition	Checks	Actions	Notes	
1a. Blower stays on high speed when ignition is on.	No other functions work.	Check for damaged pins or wires in control head plug.	Verify that all pins are inserted into plug. Ensure that no pins are bent or damaged in ECU.	Loss of ground on this wire renders control head inoperable.	
		Check for damaged ground wire (white) in control head harness.	Verify continuity to chassis ground with white control head wire at various points.		
		Check for damaged blower switch or potentiometer and associated wiring.	See blower switch check procedure.		
	All other functions work.	Unplug 3-wire BSC control connector from ECU. If blower shuts off, ECU is either improperly wired or damaged.	Be sure the small, 20 GA white ground wire is connected to the battery ground post. If it is, replace the ECU.		
1b. Blower stays on high speed when ignition is on or off.		Unplug 3-wire BSC control connector from ECU. If blower stays running, BSC is either improperly wired or damaged.	Check to ensure that no BSC wiring is damaged or shorted to vehicle ground. The BSC operates the blower by ground side pulse width modulation switching. The positive wire to the blower will always be hot. If the "ground" side of the blower is shorted to chassis ground, the blower will run on HI.	No other part replacements should be necessary.	
		System must be charged for compressor to engage.	Replace BSC (This will require removal of evaporator from vehicle).		
	Compressor will not turn on (All other functions work).	System is not charged.	System must be charged for compressor to engage.	Charge system or bypass pressure switch.	Danger: Never bypass safety switch with engine running. Serious injury can result.
		System is charged.	Check for faulty A/C potentiometer or associated wiring (Not applicable to 3-pot controls).	Check continuity to ground on white control head wire. Check for 5V on red control head wire.	
3. Compressor will not turn off (All other functions work).		Check for disconnected or faulty thermistor.	Check 2-pin connector at ECU housing.	Disconnected or faulty thermistor will cause compressor to be disabled.	
		Check for faulty A/C potentiometer or associated wiring.	Repair or replace pot/control wiring.	Red wire at A/C pot should have approximately 5V with ignition on. White wire will have continuity to chassis ground. White/Blue wire should vary between 0V and 5V when lever is moved up or down.	
		Check for faulty A/C relay.	Replace relay.		



Troubleshooting Guide (Cont.)

Symptom	Condition	Checks	Actions	Notes
4. System will not turn on, or runs intermittently.	Works when engine is not running; shuts off when engine is started (Typically early Gen IV, but possible on all versions).	Noise interference from either ignition or alternator.	Install capacitors on ignition coil and alternator. Ensure good ground at all points. Relocate coil and associated wiring away from ECU and ECU wiring. Check for burned or loose plug wires.	Ignition noise (radiated or conducted) will cause the system to shut down due to high voltage spikes. If this is suspected, check with a quality oscilloscope. Spikes greater than 16V will shut down the ECU. Install a radio capacitor at the positive post of the ignition coil (See radio capacitor installation bulletin). A faulty alternator or worn out battery can also result in this condition.
	Will not turn on under any conditions.	Verify connections on power lead, ignition lead, and both white ground wires.	Check for positive power at heater valve green wire and blower red wire. Check for ground on control head white wire.	
		Verify battery voltage is greater than 10 volts and less than 16.	Verify proper meter function by checking the condition of a known good battery.	
5. Loss of mode door function.	No mode change at all.	Check for damaged mode switch or potentiometer and associated wiring.		Typically caused by evaporator housing installed in a bind in the vehicle. Be sure all mounting locations line up and don't have to be forced into position.
	Partial function of mode doors.	Check for obstructed or binding mode doors.		
		Check for damaged stepper motor or wiring.		
6. Blower turns on and off rapidly.	Battery voltage is at least 12V.	Check for at least 12V at circuit breaker.	Ensure all system grounds and power connections are clean and tight.	System shuts off blower at 10V. Poor connections or weak battery can cause shutdown at up to 11V.
	Battery voltage is less than 12V.	Check for faulty battery or alternator.	Charge battery.	
7. Erratic functions of blower, mode, temp, etc.		Check for damaged switch or pot and associated wiring.	Repair or replace.	
		This is an indicator that the system has been reset. Be sure the red power wire is on the battery post, and not on a switched source. Also, if the system is pulled below 7V for even a split second, the system will reset.	Run red power wire directly to battery.	
8. When ignition is turned on, blower momentarily comes on, then shuts off. This occurs with the blower switch in the OFF position.				



Kick Panel Modification Template

CUT ALONG
DOTTED LINE



CUT ALONG
DOTTED LINE

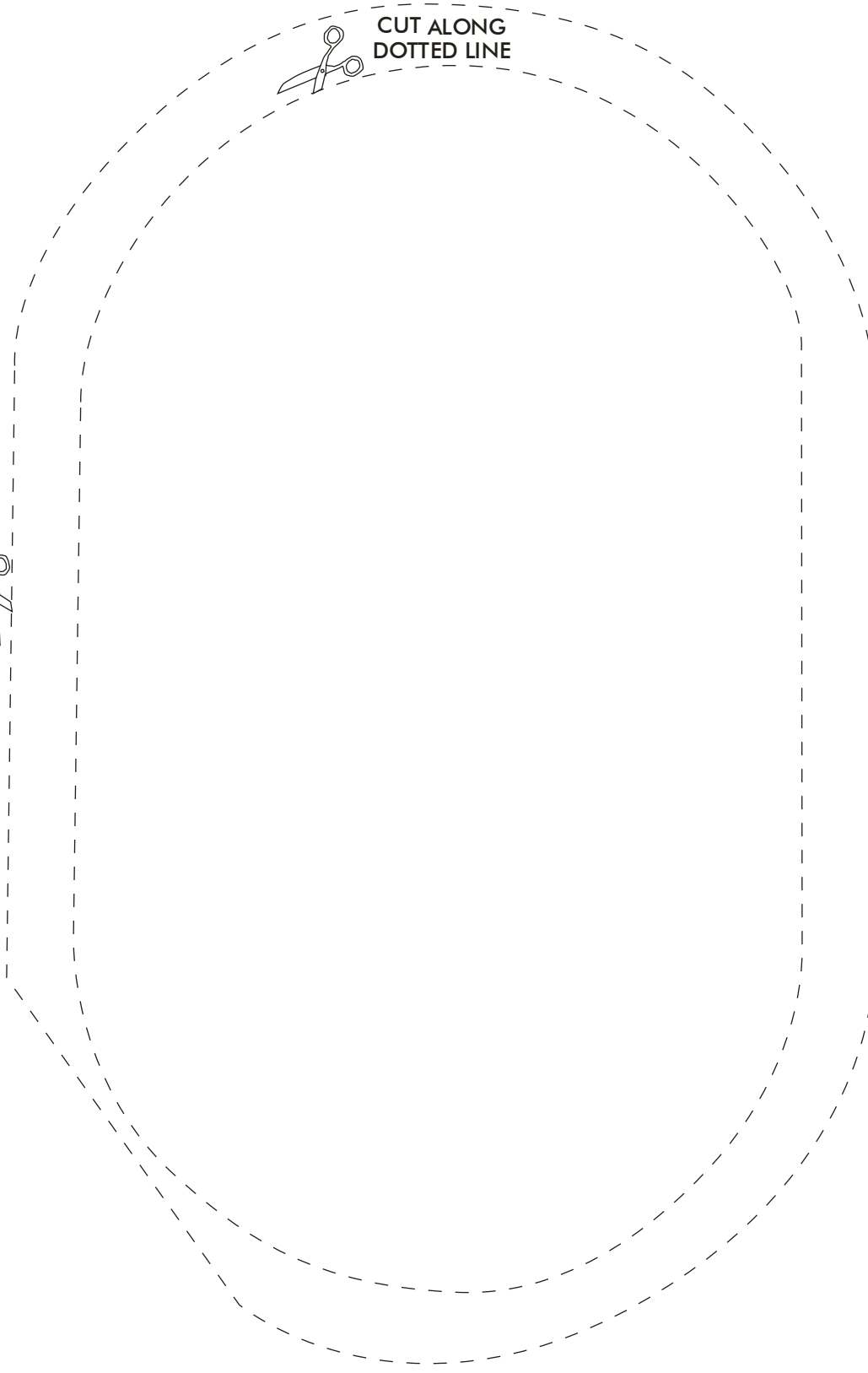



Center Louver Template

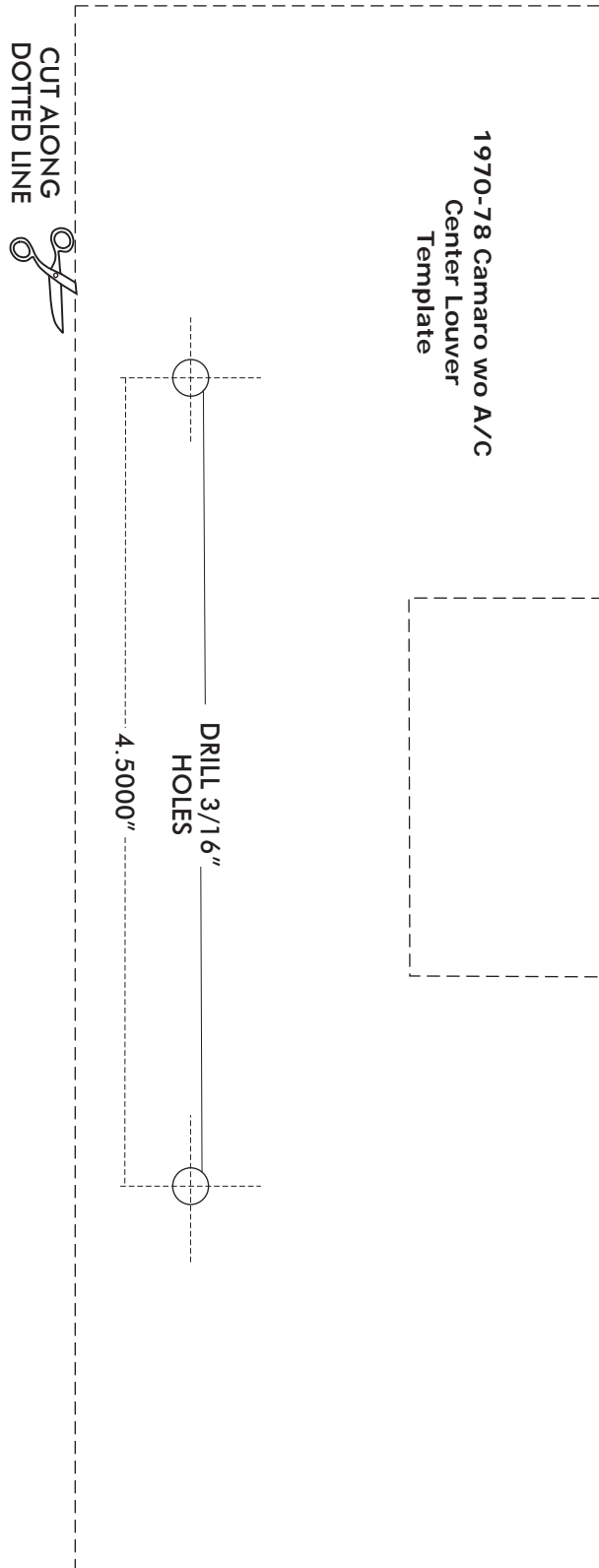



Glove Box Light Template

