

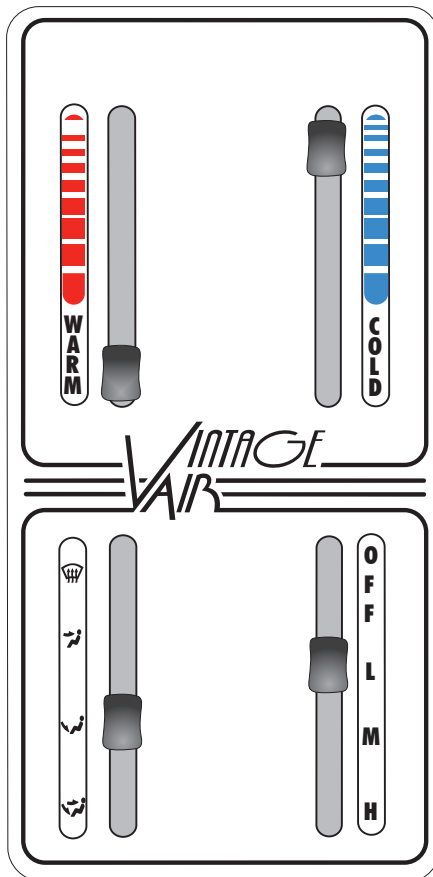

# **4 LEVER CONTROL PANEL**

MACHINED VERTICAL  
48102-SVQ





## 4 LEVER CONTROL PANEL 48102-SVQ

### CONTROL PANEL 48102-SVQ

#### CONTROL PANEL PACKING LIST

No.	QTY.	PART No.	DESCRIPTION
1.	1	11088-VUT	THERMOSTAT SWITCH w/ LEVER 42"
2.	1	11212-SUA	SLIDE POT w/ PIGTAIL
3.	2	11430-VUS	3-SPD BLOWER SWITCH
4.	4	18150-VUB	10-32 HEX NUT
5.	2	18233-VUB	6 x 3/8" PH PAN HEAD SCREW
6.	4	18415-VUB	10-32 x .75 SKT SCREW
7.	2	20557-VUP	LIGHT BULB
8.	1	23120-VUW	#10 RING TERMINAL (22/18)
9.	1	23122-VUW	1/4 SPADE TERMINAL (22/18)
10.	2	33138-VUI	1/4 RUBBER GROMMET
11.	3	49455-VUI	LEVER CONTROL KNOB
12.	1	491006-KUR	SLIDE POT KNOB
13.	1	49704-VUI	NYLON FLAT WASHER
14.	1	64119-VUB	POT RETAINING BRKT.
15.	1	64120-VUB	SWITCH MNTG BRKT.
16.	1	64128-VUB	TOP PANEL MNTG BRKT.
17.	1	64129-VUB	BOTTOM PANEL MNTG BRKT.
18.	2	23123-VUW	BUDDY CLIP
19.	2	23139-VUW	6" FM JUMPER WIRE
20.	1	18060-VUB	8-32 x 1/4" HEX SCREW
21.	4	18198-VUB	8-32 x 1/4" PH PAN HEAD SCREW
22.	1	20580-VUP	VERT HEAT LABEL
23.	1	20581-VUP	VERT COLD LABEL
24.	1	20582-VUP	VERT MODE LABEL
25.	1	20583-VUP	VERT FAN LABEL
26.	1	49098-VUI	VERT GEN II PANEL w/ LOGO

**\*\* BEFORE BEGINNING INSTALLATION, OPEN ALL PACKAGES AND CHECK CONTENTS OF SHIPMENT. PLEASE REPORT ANY SHORTAGES DIRECTLY TO VINTAGE AIR WITHIN 15 DAYS. AFTER 15 DAYS, VINTAGE AIR WILL NOT BE RESPONSIBLE FOR MISSING OR DAMAGED ITEMS.**

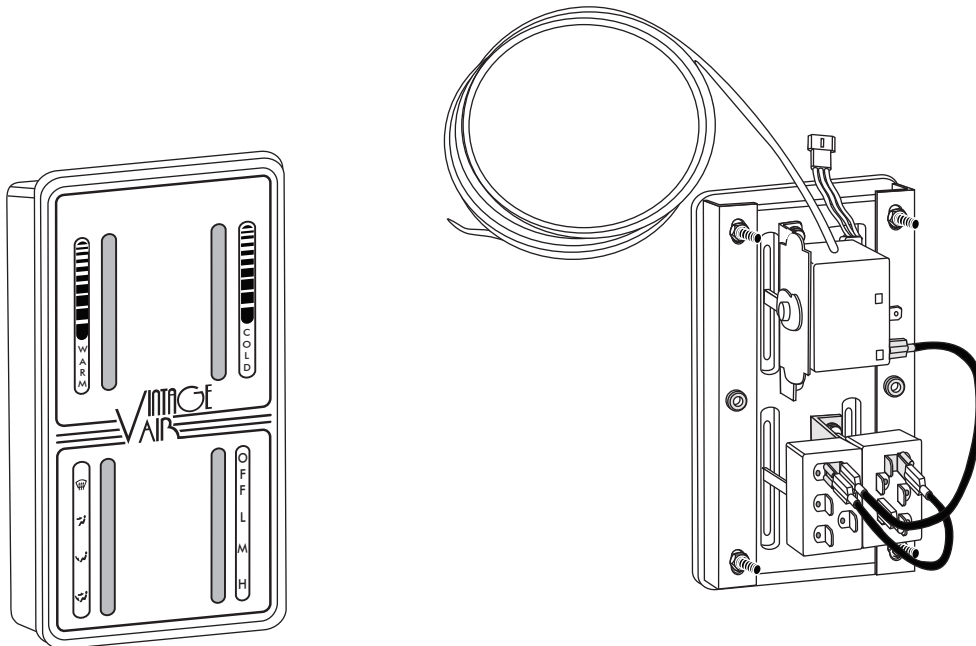



## 4 LEVER MACHINED VERTICAL CONTROL PANEL DIMENSIONS

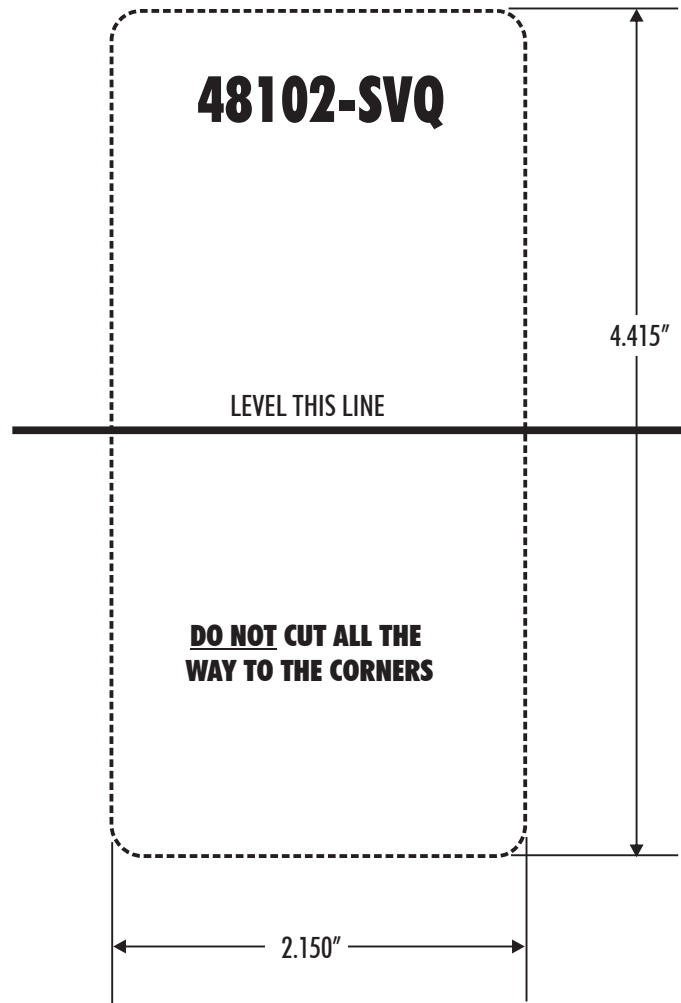

**NOTE: DRAWING IS FOR REFERENCE PURPOSES ONLY, AND SHOULD NOT BE USED AS A TEMPLATE. DUE TO PRINTER VARIATIONS, DRAWING MAY NOT BE PRINTED TO SCALE. INSTALLER SHOULD VERIFY ALL MEASUREMENTS PRIOR TO CUTTING OR DRILLING.**

### CONTROL PANEL INSTALLATION

- SELECT A SUITABLE LOCATION FOR THE CONTROL PANEL. CONSIDER HEATER CONTROL VALVE LOCATION, WIRING HARNESS LENGTH AND CAPILLARY TUBE TO EVAPORATOR DISTANCE.
- AFTER SELECTING A LOCATION FOR THE PANEL, MASK THE AREA 3"(WIDE) X 5"(TALL).
- USING MEASUREMENTS GIVEN ABOVE, MARK THE AREA TO BE CUT.
- CUT OUT THE MARKED AREA WITHOUT CUTTING OUTSIDE THE DIMENSIONS GIVEN.
- IF MORE MATERIAL MUST BE REMOVED, DO SO WITH A FILE. (REMEMBER TO PUSH TOWARD THE FIREWALL WITH THE FILE SO IT WON'T CHIP THE PAINT. DO NOT PULL IT BACKWARDS! A RAT-TAIL FILE CAN BE USED TO GET THE PROPER RADIUS IN THE CORNERS.



# 4 LEVER CONTROL PANEL 48102-SVQ

- ONCE PANEL HAS BEEN INSTALLED INTO THE HOLE, REMOVE THE MASKING TAPE AND INSTALL THE L SHAPED MOUNTING BRACKETS ONTO THE 10-32 STUDS. **(NOTE: IT IS NOT NECESSARY TO REMOVE SWITCHES OR THERMOSTAT TO INSTALL PANEL).**
- UNCOIL THE CAPILLARY TUBE FROM THE THERMOSTAT. INSERT THE TUBE INTO THE EVAPORATOR COIL TO A DEPTH OF 4-1/2". THE HOLE FOR THE CAPILLARY TUBE IS UNDER THE BLUE STICKER LOCATED ON TOP OF THE EVAPORATOR.

## WIRING DIAGRAM - GEN II UNITS 4 LEVER CONTROL

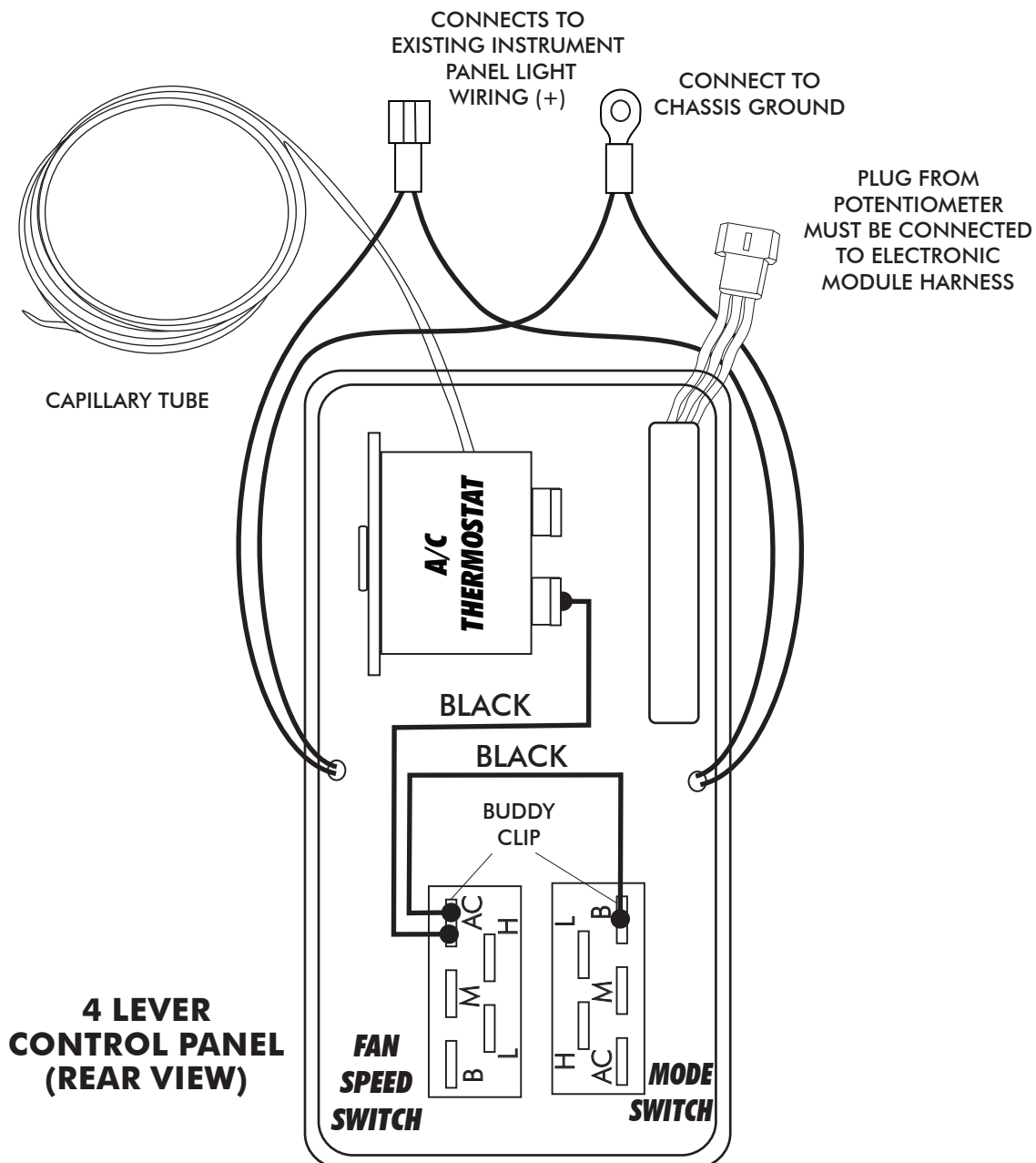

**4 LEVER CONTROL PANEL (REAR VIEW)**

- WIRE THE SYSTEM AS SHOWN ON PAGE 7 FOR GEN II COMPAC & SUPER UNITS, OR PAGE 8 FOR GEN II MINI UNITS.



## 4 LEVER CONTROL PANEL 48102-SVQ

• IF PREVIOUSLY REMOVED, REINSTALL DASH AND ENSURE THAT THE DUCT HOSE IS SECURELY ON THE DASH VENT HOSE ADAPTERS.

### CONTROL PANEL OPERATION 48102-SVQ 4 LEVER CONTROL PANEL OPERATION

**IMPORTANT NOTE: BEFORE OPERATING SYSTEM, CAREFULLY UNROLL CAPILLARY TUBE AND INSERT TO A DEPTH OF 4 1/2" THRU PRE-DRILLED HOLE IN TOP OF CASE (BLUE DOT).**

FAN SPEED CAN BE OPERATED IN ANY MODE POSITION.

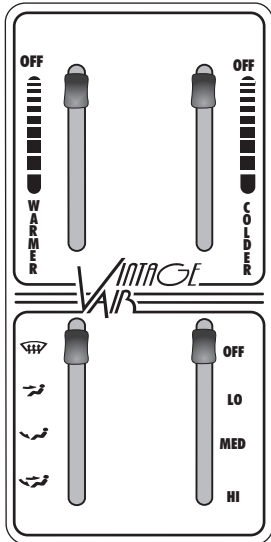

#### SYSTEM OFF

SLIDING THE FAN SPEED LEVER TO **OFF** WILL SHUT DOWN THE SYSTEM IN ANY MODE.

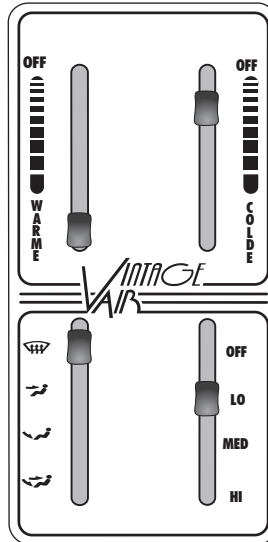

#### DEFROST MODE (OPTIONAL, FOR DEFROST ONLY!)

SELECT FAN SPEED. SET MODE SWITCH TO DEFROST. SLIDE THE COLD AIR LEVER SLIGHTLY TO RIGHT TO ENGAGE THE COMPRESSOR, AND SLIDE HOT AIR LEVER TO RIGHT TO OPEN HOT WATER VALVE AND PROVIDE HEATED DEFROST AIR. **DEHUMIDIFIED DEFROST WILL BE DIRECTED TO THE WINDSHIELD.**

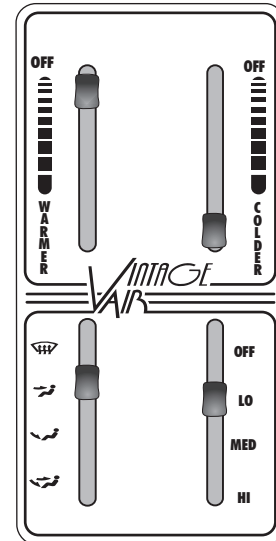

#### A/C MODE

SLIDE COLD AIR LEVER TO RIGHT FOR COLD AIR, AND ADJUST MODE LEVER TO VENT. **COLD AIR WILL FLOW OUT VENTS.** MOVING LEVER TO BI-LEVEL WILL DIRECT COLD AIR TO DASH AND FLOOR OUTLETS. **NOTE:** DUCT TEMPERATURE CAN BE RAISED BY **SLIGHTLY** SLIDING HOT AIR LEVER TO THE RIGHT TO OPEN HOT WATER VALVE. HOT WATER VALVE MUST BE CLOSED (FULL LEFT) FOR COLDEST A/C SETTING.

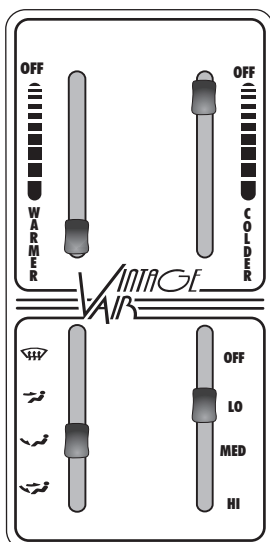

#### FLOOR HEAT MODE

SELECT FAN SPEED. SET MODE LEVER TO FLOOR, AND SLIDE THE HEAT LEVER TO THE FAR RIGHT FOR HEAT MODE. **HOT AIR WILL EXIT THE FLOOR VENTS.**

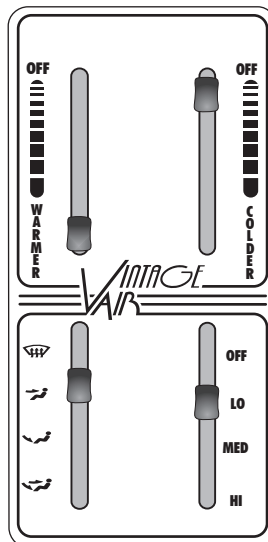

#### VENT HEAT MODE

SELECT FAN SPEED. SET MODE SWITCH TO DASH, AND SLIDE THE HEAT LEVER TO THE FAR RIGHT FOR HEAT MODE. **HOT AIR WILL EXIT THE DASH VENTS.**

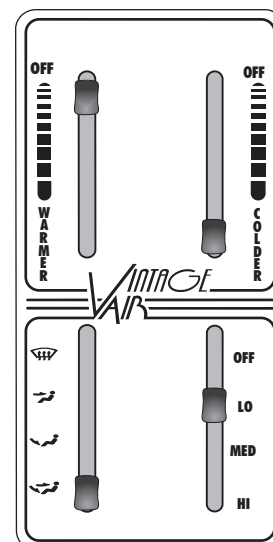

#### BI-LEVEL HEAT MODE

SELECT FAN SPEED. SET MODE SWITCH TO BI FOR BI LEVEL, AND SLIDE THE HEAT LEVER TO THE FAR RIGHT FOR HEAT. **HOT AIR WILL EXIT THE DASH VENTS & FLOOR.**



# 4 LEVER CONTROL PANEL 48102-SVQ

## WIRING DIAGRAM - GEN II COMPAC/SUPER UNITS

HEAT/COOL/DEFROST 48102-SVQ 4 LEVER CONTROL PANEL

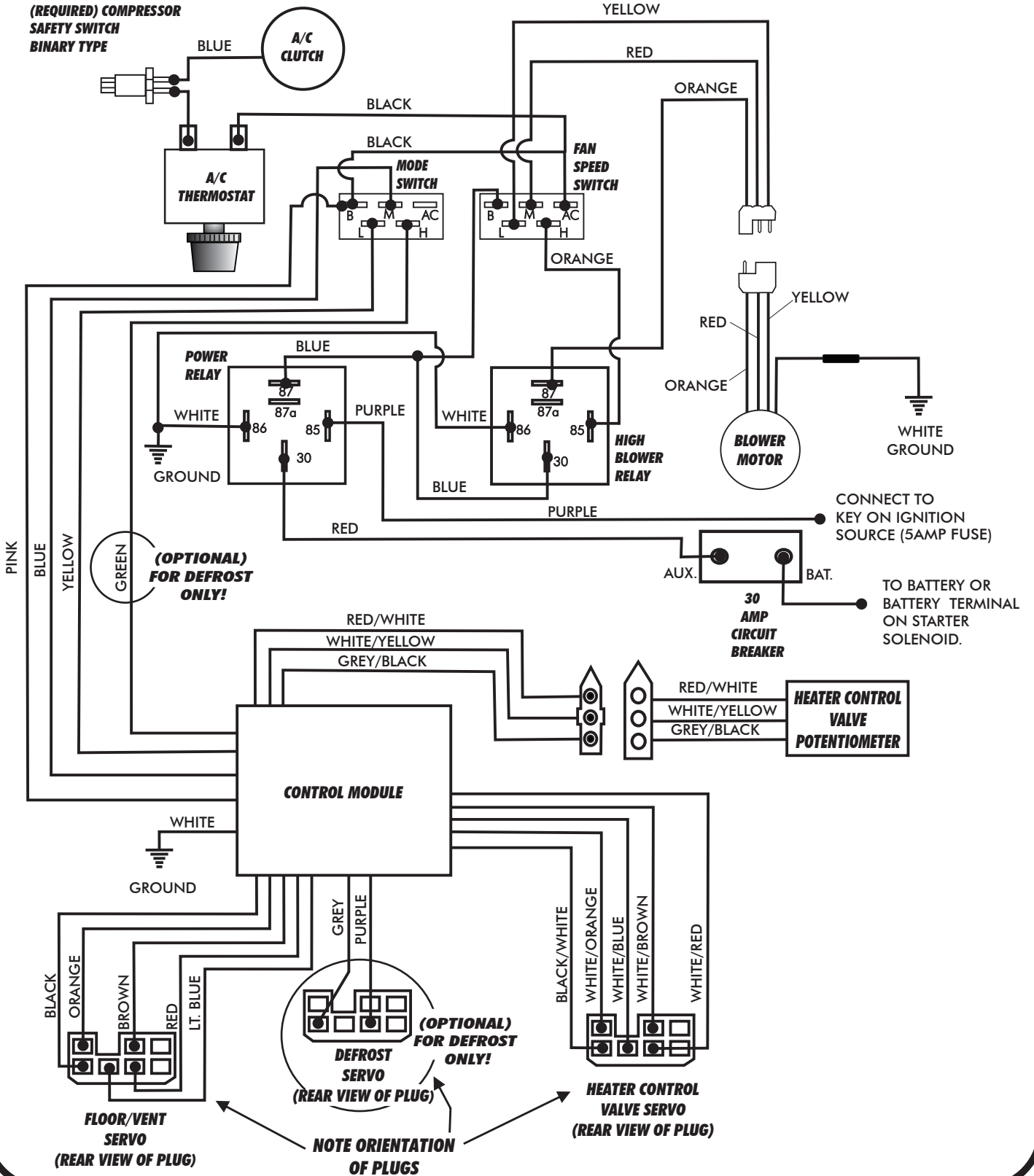



# 4 LEVER CONTROL PANEL 48102-SVQ

## WIRING DIAGRAM - GEN II MINI UNITS HEAT/COOL/DEFROST 48102-SVQ 4 LEVER CONTROL PANEL

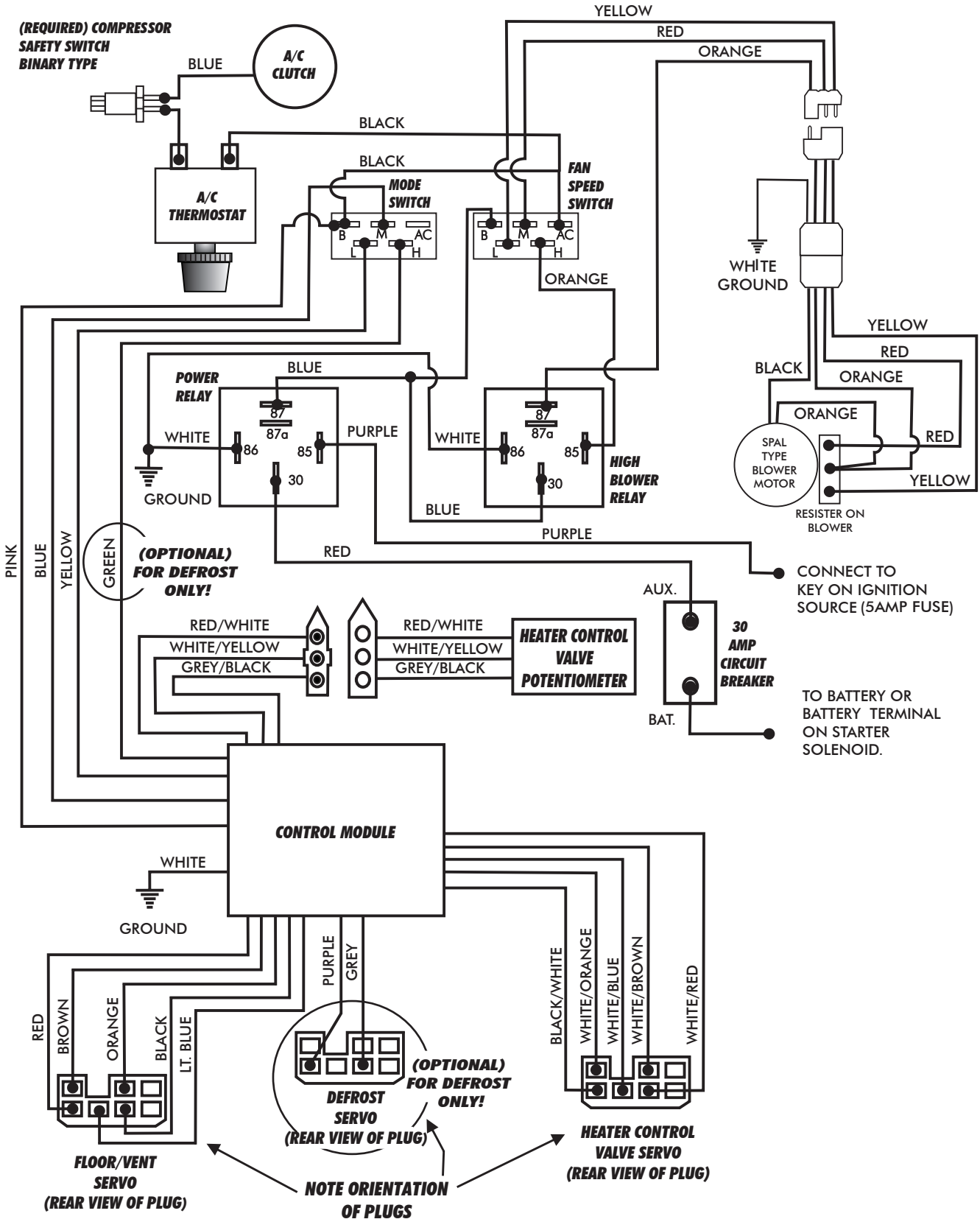



# 4 LEVER CONTROL PANEL 48102-SVQ

## CONTROL PANEL 48102-SVQ

### CONTROL PANEL PACKING LIST

No.	QTY.	PART No.	DESCRIPTION
1.	1	11088-VUT	THERMOSTAT SWITCH w/ LEVER 42"
2.	1	11212-SUA	SLIDE POT w/ PIGTAIL
3.	2	11430-VUS	3-SPD BLOWER SWITCH
4.	4	18150-VUB	10-32 HEX NUT
5.	2	18233-VUB	6 x 3/8" PH PAN HEAD SCREW
6.	4	18415-VUB	10-32 x .75 SKT SCREW
7.	2	20557-VUP	LIGHT BULB
8.	1	23120-VUW	#10 RING TERMINAL (22/18)
9.	1	23122-VUW	1/4 SPADE TERMINAL (22/18)
10.	2	33138-VUI	1/4 RUBBER GROMMET
11.	3	49455-VUI	LEVER CONTROL KNOB
12.	1	491006-KUR	SLIDE POT KNOB
13.	1	49704-VUI	NYLON FLAT WASHER
14.	1	64119-VUB	POT RETAINING BRKT.
15.	1	64120-VUB	SWITCH MNTG BRKT.
16.	1	64128-VUB	TOP PANEL MNTG BRKT.
17.	1	64129-VUB	BOTTOM PANEL MNTG BRKT.
18.	2	23123-VUW	BUDDY CLIP
19.	2	23139-VUW	6" FM JUMPER WIRE
20.	1	18060-VUB	8-32 x 1/4" HEX SCREW
21.	4	18198-VUB	8-32 x 1/4" PH PAN HEAD SCREW
22.	1	20580-VUP	VERT HEAT LABEL
23.	1	20581-VUP	VERT COLD LABEL
24.	1	20582-VUP	VERT MODE LABEL
25.	1	20583-VUP	VERT FAN LABEL
26.	1	49098-VUI	VERT GEN II PANEL w/ LOGO

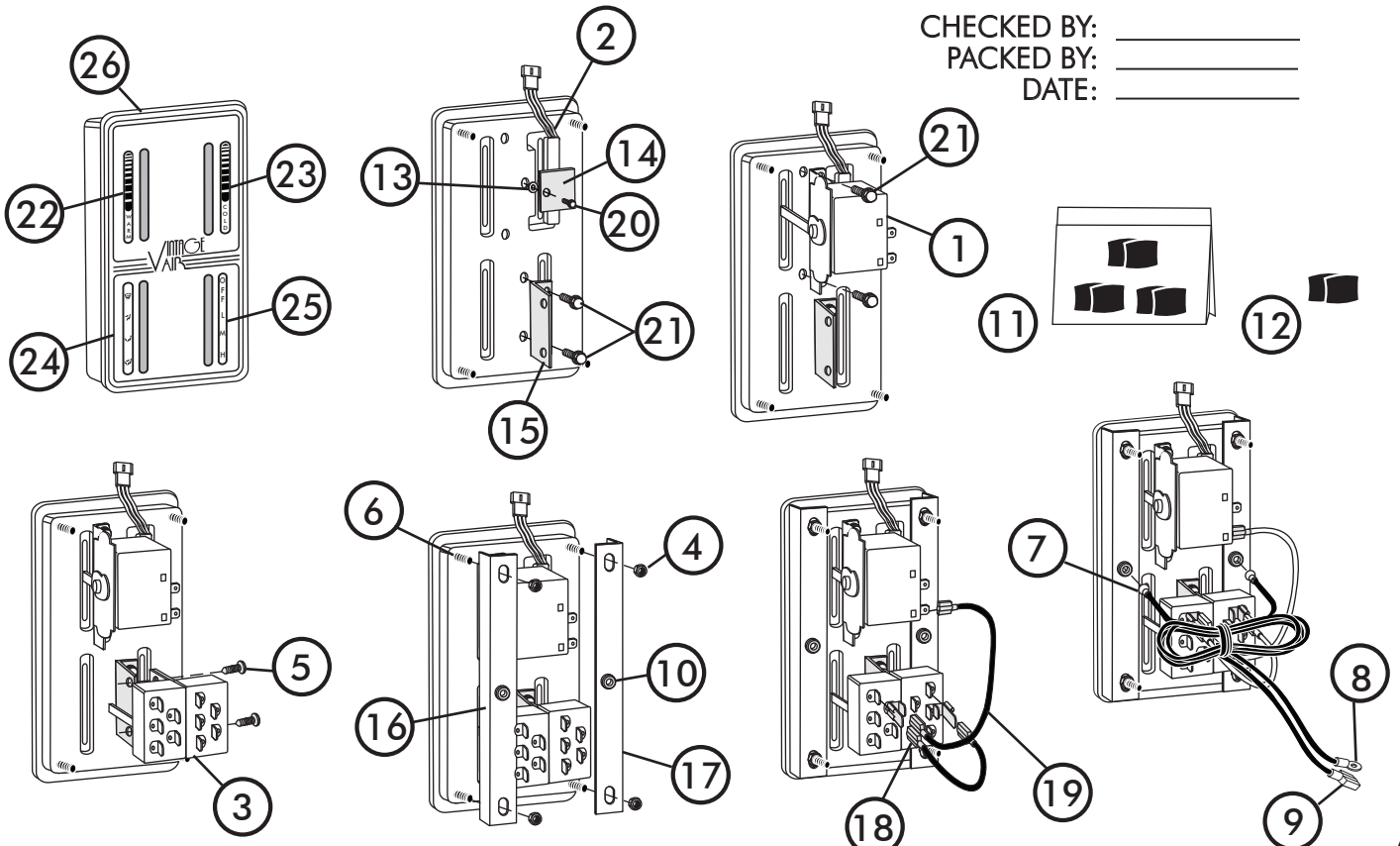

CHECKED BY: \_\_\_\_\_  
 PACKED BY: \_\_\_\_\_  
 DATE: \_\_\_\_\_