



## 200 PSI COMPRESSORS - MODEL NUMBERS

- 380C AIR COMPRESSOR KIT  
PART NO. 38033
  
- 480C AIR COMPRESSOR KIT  
PART NO. 48043



### **IMPORTANT:**

It is essential that you and any other operator of this product read and understand the contents of this manual before installing and using this product.

**SAVE THIS MANUAL FOR FUTURE REFERENCE**

**USER MANUAL**



## 380C - 480C COMPRESSOR KIT

### IMPORTANT SAFETY INSTRUCTIONS

---

**CAUTION** - To reduce risk of electrical shock or electrocution:

- Do not disassemble. Do not attempt repairs or modifications. Refer to qualified service agencies for all service and repairs.
- Do not use this product in an area where it can fall or be pulled into water or other liquids.
- Do not reach for this product if it has fallen into liquid.
- Use this compressor with 12-volt DC systems only.
- This product should never be left unattended during use.

**WARNING - To prevent injury:**

- Never allow children to operate this compressor. Close supervision is necessary when this compressor is being used near children.
- This compressor will become very HOT during and immediately after use. Do not touch any part of this compressor with bare hands, during and immediately after use.
- Do not use this product near flames or explosive materials or where aerosol products are being used.
- Do not operate this product where oxygen is being administered.
- Do not pump anything other than atmospheric air.
- Never use this product while sleepy or drowsy.
- Do not use any tools or attachments without first determining maximum air pressure for that tool or attachment.
- Never point any air nozzle or air sprayer toward another person or any part of the body.
- This air compressor is equipped with an Automatic Reset Thermal Protector, and can automatically restart after the thermal protector resets. Always cut off power source when thermal protector becomes activated.
- Wear safety glasses or goggles when operating this product.
- Use only in well ventilated areas.

### INSTALLATION

---

Please read and follow the Installation Instructions carefully to avoid injury or damage to the compressor or your vehicle.

Each of our air compressors and parts have been carefully produced and packaged. Before installation, please familiarize yourself with Installation Parts List (Fig. 1) of this manual.

#### **Guidelines for Selecting Mounting Location:**

The selection of proper mounting location for your air compressor will help ensure a long and trouble free compressor service life. Please pay close attention to the following guidelines:

1. Select a FLAT, UPRIGHT AND SECURE location where the compressor can be mounted.
2. To maximize air compressor performance, locate compressor as CLOSE TO THE BATTERY as possible so that length of positive lead wire required is at a minimum.
3. Choose mounting location that is as cool as possible and AWAY FROM HEAT SOURCES. The cooler the ambient temperature, the less chance the compressor will overheat.
4. This compressor is moisture & splash resistant, but NOT WATERPROOF. Do not mount compressor in locations where the unit is likely to come in contact with water.
5. For remote filter mounting, select compressor's mounting location where air line can be routed from compressor air inlet to remote inlet air filter. Make sure Remote Inlet Air Filter is located in a dry location, away from the elements.
6. You will also want to select compressor mounting location where the leader hose bracket can be mounted to secure the leader hose.
7. If it is necessary to mount the air compressor further away from the battery, such as inside your vehicle or in the bed of your pickup, use a minimum 8 AWG positive lead wire for remote installation.
8. Do not mount compressor near areas where flammable liquids are stored.
9. Use thread sealant for proper fitting installation. Thread tape is not recommended. Properly sealed, recommended torque is 12 to 15 ft. lbs

## 380C - 480C COMPRESSOR KIT

### MOUNTING AND WIRING

1. Disconnect ground cable from vehicle's battery.
2. Temporarily position the air compressor in the location where it will be mounted.
3. Route ground wire to the negative post of the battery or to an appropriate grounding point and cut ground wire to length as needed.
4. Mount air compressor with the four sets of bolts, nuts, washers, and locking washers provided. (See Fig. 2 for Mounting Instructions) Use of thread sealant is recommended.
5. **NOTE:** For Remote Inlet Air Filter Installation, refer to Remote Inlet Air Filter Installation Instructions included in the Remote Inlet Air Filter Pack.
6. VIAIR air compressor(s) come equipped with heavy duty heat resistant leader hose(s) with either 1/4" or 3/8" NPT fittings. This leader hose is designed to prolong the life of your air line. Do not remove this leader hose from air compressor.
7. **IMPORTANT:** Please note, the leader hose that comes with your compressor has a built-in inline check valve. Do Not remove inline check valve from leader hose.
8. Select proper location to mount leader hose with hose bracket provided. Avoid locations where leader hose may become tangled with wires and other hoses.
9. To mount hose bracket, drill hole with 3/16" drill bit and push self-anchoring hose bracket pin into hole. Route leader hose through hose bracket and secure hose by pressing bracket clamp into locked position.
10. To remove hose from the hose bracket, simply press down on the hose clamp release tab to release bracket clamp. (Fig. 3)
11. Connect compressor's positive lead wire to one of the leads of your pressure switch.
12. Make sure that your compressor setup is properly fused. For appropriate fuse size, refer to amp draw of compressor in the specifications section of this manual.
13. Always locate fuse as close as possible to power source.
14. Before connecting to power source, re-check to make sure that all connections are made properly.
15. Connect and test compressor system by running the compressor for a short time to build up pressure in your air tank.
16. Once air pressure reaches preset cut out pressure of your pressure switch, the compressor will shut off. Inspect all air line connections for leaks with soap and water solution. If a leak is detected, the air line may not be cut squarely or pushed all the way in. Repair connections as needed.

(Fig. 1) 380C / 480C Compressor Installation Parts List:

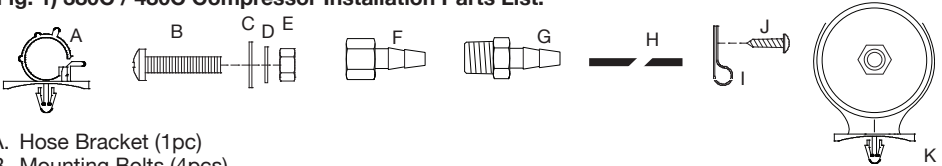

- A. Hose Bracket (1pc)
- B. Mounting Bolts (4pcs)
- C. Flat Washers (8pcs)
- D. Locking Washers (4pcs)
- E. Nuts (4pcs)
- F. 3/8NPT F x 1/2" Barbed Fitting (1pc) (480C)  
1/4NPT F x 3/8" Barbed Fitting (1pc) (380C)
- G. 3/8NPT M x 1/2" Barbed Fitting (1pc) (480C)  
1/4NPT M x 3/8" Barbed Fitting (1pc) (380C)
- H. Remote Mount Filter Air Line (1pc)
- I. Air Line Clips (3pcs)
- J. Screws (3pcs)
- K. Remote Inlet Air Filter with Filter Element (1pc)

## 380C - 480C COMPRESSOR KIT

**(Fig. 2) Compressor Mounting Hardware**

B. Mounting Bolt

C. Flat Washer

D. Locking Washer

E. Nut

F. Vibration Isolator

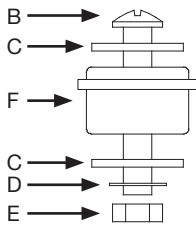

**(Fig. 3) Leader Hose Bracket**

L. Hose Clamp

M. Clamp Release Tab

N. Self-Anchoring Pin

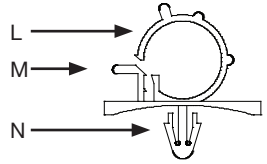

## OPERATING INSTRUCTIONS

1. **IMPORTANT:** Always operate the compressor at or below the **MAXIMUM PRESSURE RATING** of the compressor. Please refer to Application & Specifications Sections of this manual for details.
2. Always observe the **MAXIMUM DUTY CYCLE** of the air compressor. Refer to Compressor Applications and Specifications Sections of this manual for details. Operation exceeding maximum pressure ratings and/or duty cycle will result in damage to the air compressor.
3. Your air compressor is equipped with an **AUTOMATIC THERMAL OVERLOAD PROTECTOR**. This feature is designed to protect the air compressor from overheating and causing permanent damage to your air compressor. The thermal overload protector will automatically cut power to your air compressor should the internal operating temperature of the air compressor rise above safe levels during excessive use.
4. Should at any time during use, your air compressor automatically shuts off, do not attempt to restart the air compressor. Turn power to the air compressor OFF. The automatic thermal overload protector will automatically reset when internal temperature of the air compressor drops below safe level. After allowing air compressor to cool off for about 30 minutes, you can safely resume use of the air compressor.
5. To prevent discharge of your vehicle's battery, we recommend that you keep the vehicle's engine running while using the air compressor.
6. **ONLY OPERATE THE AIR COMPRESSOR IN WELL-VENTILATED AREAS.**
7. Compressor performance is enhanced when operating compressor with vehicle's engine running.

## MAINTENANCE & REPAIRS

1. Periodically check all electrical, fittings connections. Clean and tighten as needed.
2. Periodically check all mounting screws. Tighten as needed.
3. Replace Air Filter Element periodically. Replacement frequency depends on operating frequency and operating environment. For frequent use in dusty environment, we recommend that you replace air filter element at least once a month.
4. Regularly clean dust and dirt from compressor cooling fins and motor housing.
5. Your air compressor is equipped with a permanently lubricated, maintenance-free motor. Never try to lubricate the compressor.
6. All repairs should be performed by Manufacturer or Manufacturer's Authorized Service Agencies only.

### CAUTION:

Never touch the air compressor or fittings connected to the air compressor with bare hands during or immediately after use. The leader hose and fittings connected to leader hose will become very HOT during and after use. If necessary, wear heat resistant gloves to handle fittings, air line, and leader hose.

## 380C - 480C COMPRESSOR KIT

### SPECIFICATIONS

---

• Part No 38033 / 380C Air Compressor (CE Spec.)

Motor Voltage:	12 Volts
Max. Current Consumption:	23 Amps
Recommended Fuse:	30 Amps
Motor Type:	Permanent Magnetic
Horsepower:	1/4
Max. Working Pressure:	200 PSI
Max. Duty Cycle (@ 72°F & 100/200 PSI):	100% / 55%
Minutes On/Off (@ 72°F & 100 PSI):	Continuous
Max. Ambient Temperature:	158°F
Min. Ambient Temperature:	-40°F
Auto. Reset Thermal Protection:	Yes
Dimensions:	9"L x 4"W x 6.75"H
Net Weight:	8.75 Lbs.

• Part No. 48043 / 480C Air Compressor (CE Spec.)

Motor Voltage:	12 Volts
Max. Current Consumption:	23 Amps
Recommended Fuse:	30 Amps
Motor Type:	Permanent Magnetic
Horsepower:	1/4
Max. Working Pressure:	200 PSI
Max. Duty Cycle (@ 72°F & 100/200 PSI):	100% / 50%
Minutes On/Off (@ 72°F & 100 PSI):	Continuous
Max. Ambient Temperature:	158°F
Min. Ambient Temperature:	-58°F
Auto. Reset Thermal Protection:	Yes
Dimensions:	10.87"L x 4.2"W x 6.75"H
Net Weight:	11.05 Lbs.

## 380C - 480C COMPRESSOR KIT

### COMPRESSOR APPLICATION GUIDE

---

To ensure that you get the highest level of satisfaction from your compressor's performance, refer to information below:

#### VIAIR COMPRESSOR REFERENCE CHART

COMPRESSOR SERIES	DUTY CYCLE (100 PSI @ 72°F)	MAX. WORKING PRESSURE
090 SERIES	9%	120 PSI
092 SERIES	9%	120 PSI
095 SERIES	9%	120 PSI
097 SERIES	10%	130 PSI
098 SERIES	10%	130 PSI
100 SERIES	15%	130 PSI
250 IG SERIES	100%	150 PSI
275 SERIES	25%	150 PSI
280 SERIES	30%	150 PSI
325 SERIES	33%	150 PSI
330 IG SERIES	100%	150 PSI
350 SERIES	100%	150 PSI
380 SERIES	100%	200 PSI
	*55%	
400 SERIES	33%	150 PSI
420 SERIES	33%	150 PSI
444 SERIES	100%	200 PSI
	*50%	
450 SERIES	100%	150 PSI
450 IG SERIES	100%	150 PSI
460 SERIES	100%	150 PSI
480 SERIES	100%	200 PSI
	*50%	

*\*Duty Cycle at 200 PSI and 72°F.*

#### ABOUT COMPRESSOR DUTY CYCLE:

Duty cycle refers to the amount of time a compressor can be operated in a given time period at 100 PSI, and a standard ambient temperature of 72° F. It is commonly expressed in percentage format: Compressor on time ÷ (on time + off time) = Duty Cycle %.

#### ONE-HOUR DUTY CYCLE

(100 PSI @ 72°F)

	MINUTES ON / MINUTES OFF
9%	5 Min. On / 55 Min. Off
10%	6 Min. On / 54 Min. Off
15%	9 Min. On / 51 Min. Off
20%	12 Min. On / 48 Min. Off
25%	15 Min. On / 45 Min. Off
30%	18 Min. On / 42 Min. Off
33%	20 Min. On / 40 Min. Off
50%	30 Min. On / 30 Min. Off
100%	1 Hour Run Time

**NOTE:** All compressors, regardless of rated duty cycle, require sufficient rest time in between cycles to allow for partial or complete heat dissipation. Heat dissipation rates may vary depending on ambient temperatures and operating conditions.

#### ABOUT RATED WORKING PRESSURE:

To ensure trouble free service life of your compressor, always operate compressor within rated working pressure of the compressor. Never use a pressure switch with a higher cut-off pressure than compressor's rated working pressure.

## 380C - 480C COMPRESSOR KIT

### TROUBLESHOOTING GUIDE:

PROBLEM:	POSSIBLE CAUSE(S)	CORRECTIVE ACTION
Tank pressure drops when compressor(s) shut off	<ol style="list-style-type: none"><li>1. Loose drain cock</li><li>2. Check valve leaking</li><li>3. Loose connections</li></ol>	<ol style="list-style-type: none"><li>1. Tighten drain cock</li><li>2. Replace check valve or compressor</li><li>3. Check all connections with soap and water solution and tighten</li></ol>
Compressor runs continuously and air flow lower than normal	<ol style="list-style-type: none"><li>1. Excessive air usage</li><li>2. Loose connections</li><li>3. Worn piston ring or inlet valve.</li><li>4. Clogged air filter element</li></ol>	<ol style="list-style-type: none"><li>1. Decrease air usage</li><li>2. Check all connections with soap and water solution and tighten.</li><li>3. Replace compressor</li><li>4. Replace air filter element</li></ol>
Compressor runs continuously causing safety valve (if equipped) to open	<ol style="list-style-type: none"><li>1. Faulty pressure switch</li><li>2. Defective safety valve</li></ol>	<ol style="list-style-type: none"><li>1. Replace pressure switch</li><li>2. Replace safety valve</li></ol>
Excessive moisture in discharge	<ol style="list-style-type: none"><li>1. Excessive water in air tank</li><li>2. High humidity</li></ol>	<ol style="list-style-type: none"><li>1. Drain tank, tilt tank to drain. Drain tank more frequently</li><li>2. Move compressor to area with less humidity, or use air line filter</li></ol>
Compressor will not run	<ol style="list-style-type: none"><li>1. No power, or power switch in OFF position</li><li>2. Blown fuse</li><li>3. Motor overheats</li><li>4. Faulty pressure switch (if hooked up to a pressure switch).</li></ol>	<ol style="list-style-type: none"><li>1. Make sure compressor switch is ON</li><li>2. Disconnect compressor from power source, replace fuse. (Refer to Specifications section for correct fuse amperage)</li><li>3. Let compressor cool off for about 30 minutes to allow thermal overload switch to reset.</li><li>4. Replace pressure switch</li></ol>
Thermal overload protector cuts out repeatedly	<ol style="list-style-type: none"><li>1. Lack of proper ventilation or ambient temperature is too high</li><li>2. Compressor valves failed</li></ol>	<ol style="list-style-type: none"><li>1. Move compressor to well ventilated area, or area with lower ambient temperature</li><li>2. Replace compressor</li></ol>
Excessive knocking or rattling	<ol style="list-style-type: none"><li>1. Loose mounting bolts</li><li>2. Worn bearing on eccentric or motor shaft</li><li>3. Cylinder or piston ring is worn</li></ol>	<ol style="list-style-type: none"><li>1. Tighten bolts</li><li>2. Replace bearing or piston assembly</li><li>3. Replace piston or compressor</li></ol>

**CAUTION: NEVER DISASSEMBLE COMPRESSOR WHILE COMPRESSOR IS PRESSURIZED.**

# 380C - 480C COMPRESSOR KIT

## AMERICAN WIRE GAUGE GUIDE 12-VOLT:

Amp Draw	Length of wire from battery to compressor (in feet)			
	5	10	15	20
5	16	16	16	14
10	16	14	12	10
15	16	12	10	10
20	14	10	10	8
25	14	10	8	6
30	12	10	8	6
40	12	8	6	6
50	10	6	6	4
60	10	6	4	4

**Wiring Diagram:**  
(Fuse Not Included)

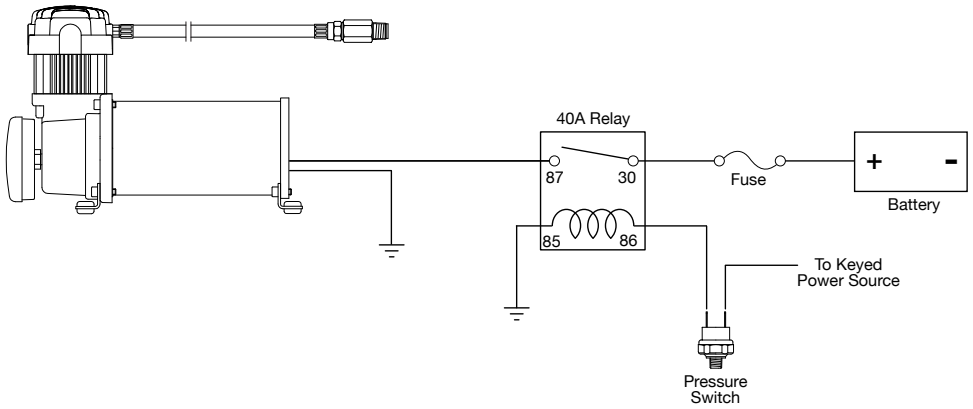

**VI AIR**<sup>®</sup>  
*Your Vital Air Source*