

VIAIR[®]
Your Vital Air Source



- 40049 – Heavy Duty ADA System Universal
- 45055 – Constant Duty ADA System Universal



IMPORTANT:

It is essential that you and any other operator of this product read and understand the contents of this manual before installing and using this product.

SAVE THIS MANUAL FOR FUTURE REFERENCE

USER MANUAL



AUTOMATIC DEPLOYMENT AIR SYSTEMS

IMPORTANT SAFETY INSTRUCTIONS

CAUTION - To reduce risk of electrical shock or electrocution:

- Do not disassemble. Do not attempt repairs or modifications. Refer to qualified service agencies for all required service and repairs.
- Do not use this product in or area where it can fall or be pulled into water or other liquids.
- Do not reach for this product if it has fallen into liquid.
- Use this compressor with 12-volt DC systems only.
- This product should never be left unattended during use.

WARNING - To prevent injury:

- Never allow children to operate this compressor. Close supervision is necessary when this compressor is being used near children.
- This compressor will become very HOT during and immediately after use. Do not touch any part of this compressor with bare hands other than the ON/OFF switch, during and immediately after use.
- Do not use this product near flames or explosive materials or where aerosol products are being used.
- Do not operate this product where oxygen is being administered.
- Do not pump anything other than atmospheric air.
- Never use this product while sleepy or drowsy.
- Do not use any tools or attachments without first determining maximum air pressure for that tool or attachment.
- Never point any air nozzle or air sprayer toward another person or any part of the body.
- This air compressor is equipped with an Automatic Reset Thermal Protector, and can automatically restart after the thermal protector resets. Always cut off power source when thermal protector becomes activated.
- Wear safety glasses or goggles when operating this product.
- Use only in well ventilated areas.

INSTALLATION

Please read and follow the installation instructions carefully to avoid injury or damage to the compressor or your vehicle.

Each of our air compressors and parts have been carefully produced and packaged. Before you begin installation, please familiarize yourself with **ADA System Components List** of this manual.

Guidelines for Selecting Mounting Location:

The selection of proper mounting location for your air compressor will help ensure a long and trouble free compressor service life. Please pay close attention to the following guidelines:

1. Select a FLAT, UPRIGHT, AND SECURE location where the compressor can be mounted.
2. The cooler the ambient temperature, the less chance the compressor will overheat. For prolonged use (tire filling) open your hood to allow maximum cooling of the compressor unit.
3. This compressor is moisture & dust resistant, but NOT DIRT OR WATERPROOF. Do not mount compressor in locations where the unit is likely to come in contact with the elements.
4. Always utilize the supplied remote filter mounting option, and route the air line from compressor air inlet to remote inlet air filter located in a clean and dry area. Secure the air filter to keep it from dislodging and becoming damaged.
5. If it is necessary to mount the air compressor further away from the battery, such as inside your vehicle or in the bed of your pickup, use the appropriate gauge wire for the amp draw of the compressor and distance from the battery. When in doubt, use the next larger wire gauge size.

AUTOMATIC DEPLOYMENT AIR SYSTEMS

MOUNTING AND WIRING

1. Disconnect ground cable from vehicle's battery.
2. Position the air compressor in the location where it will be mounted. Mount air compressor to either a flat surface with the bolts, nuts, washers, and locking washers provided.
3. NOTE: For remote inlet air filter installation, refer to instructions included in the Remote Inlet Air Filter Pack.
4. Route the provided wiring harness from the mounting location of the ADA System to the battery of your vehicle. Secure the harness as needed at several points, to avoid abrasion and other possible damage resulting from movement during vehicle use. Special care must be taken when routing the harness through sheetmetal to avoid abrasion.
5. Make sure that your compressor setup is properly fused by installing the provided fuse in the wiring harness assembly.
6. Before connecting to power source, re-check your system to make sure that all electrical connections are made properly.
7. Connect power lead of the wiring harness to the battery. It is recommended to provide switched power for the system, that is only turned on when the ignition of the vehicle is also energized in case of any air leaks that may allow the system to turn on and drain your battery during periods when the vehicle might remain parked. This is especially important when using a small reservoir, as is supplied with all ADA Systems.
8. Connect the ADA System's Delphi connector to corresponding Delphi plug connector of the wiring harness provided.
9. Ensure that the drain valve located on the underside of the ADA System reservoir is closed.
10. When power is made available to the ADA system, the system will automatically turn on and fill the ADA reservoir.
11. When the cutoff pressure of the ADA System has been reached, the system will shut off automatically.
12. Inspect all air line connections for leaks with soap and water solution. If a leak is detected, the connection may not be made properly. Re-do any connections that are leaking. The use of thread locker is recommended for all fittings. *(Avoid the use of thread tape).*

ADA SYSTEM COMPONENTS LIST:

- Qty. 1: ADA System compressor with pre-installed safety valve, drain, 85/105 PSI pressure switch, 8-1/4" NPT hex port plugs, quick connect coupler and Delphi connector
- Qty. 1: Digital tire inflation gun
- Qty. 1: 30' polyurethane hose with automatic couplers
- Qty. 2: BSP adapters (1/4" NPT to 1/8" BSP)
- Qty. 1: 40-amp blade-style fuse
- Qty. 1: 1" NPT male barbed fitting for 1/4" air line (for remote mount air filter installation)
- Qty. 1: 1" NPT female barbed fitting for 1/4" air line (for remote mount air filter installation)
- Qty. 1: Coiled airline (for remote mount air filter installation)
- Qty. 1: Air filter housing
- Qty. 1: Replacement air filter elements
- Qty. 1: Wiring harness
- Qty. 1: Toggle switch (main in-cabin power switch)

AUTOMATIC DEPLOYMENT AIR SYSTEMS

OPERATING INSTRUCTIONS

1. **IMPORTANT:** Always operate the compressor at or below the **MAXIMUM PRESSURE RATING** of the compressor. Please refer to Application & Specifications Sections of this manual for details.
2. Always observe the **MAXIMUM DUTY CYCLE** of the air compressor. Refer to Compressor Applications and Specifications Sections of this manual for details. Operation exceeding maximum pressure ratings and/or duty cycle will result in damage to the air compressor.
3. Your air compressor is equipped with an **AUTOMATIC THERMAL OVERLOAD PROTECTOR**. This feature is designed to protect the air compressor from overheating and causing permanent damage to your air compressor. The thermal overload protector will automatically cut power to your air compressor should the internal operating temperature of the air compressor rise above safe levels during excessive use.
4. Should at any time during use, your air compressor automatically shuts off unexpectedly; do not attempt to restart it. Turn off power and allow unit to cool for at least 30 minutes. This will allow the Thermal Overload Protector to reset so you can safely resume use of the air compressor.
5. To prevent discharge of your vehicle's battery, and enhance performance, keep the vehicle's engine running while using the compressor.
6. Only operate compressor in well ventilated areas.

NOTE: Your ADA System is equipped with an 85 PSI turn-on, 105 PSI turn-off pressure switch. Due to manufacturing tolerances, a variance of +/- 5% is possible for turn on & off pressures. This is not a manufacturing defect, and will not affect the operation of air lockers, nor the ability of the ADA System to inflate tires up to 100 PSI.

MAINTENANCE & REPAIRS

1. Periodically check all electrical and fittings connections. Clean and tighten as needed.
2. Periodically check all mounting screws. Tighten as needed.
3. Replace air filter element periodically. Replacement frequency depends on operating frequency and operating environment. For frequent use in dusty environment, we recommend that you replace air filter element at least once a month.
4. Regularly clean dust and dirt from compressor cooling fins and/or motor housing.
5. Your air compressor is equipped with a permanently lubricated, maintenance-free motor. Never try to lubricate the compressor.
6. All repairs should be performed by Manufacturer or Manufacturer's Authorized Service Agencies only.

CAUTION:

Never touch the air compressor or fittings connected to the air compressor, with bare hands during or immediately after use. The leader hose and fittings connected to leader hose will become very **HOT** during and after use. If necessary, wear heat resistant gloves to handle fittings, air line, and leader hose.

SPECIFICATIONS

HEAVY DUTY ADA PART NUMBERS:

- 40049 – Heavy Duty ADA System Universal

Motor Voltage:	12 volts
Max. Current Consumption:	28 amps
Recommended Fuse:	40 amps
Motor Type:	Permanent Magnetic
Horsepower:	1/4
Max. Working Pressure:	150 PSI
Max. Duty Cycle (@72°F & 100 PSI):	33%
Minutes On/Off (@72°F & 100 PSI):	20 On/ 40 Off
Max. Ambient Temperature:	158°F
Min. Ambient Temperature:	-40°F
Auto. Reset Thermal Protection:	Yes

AUTOMATIC DEPLOYMENT AIR SYSTEMS

CONSTANT DUTY ADA PART NUMBERS:

- 45055 – Constant Duty ADA System Universal

Motor Voltage:	12 volts
Max. Current Consumption:	23 amps
Recommended Fuse:	30 amps
Motor Type:	Permanent Magnetic
Horsepower:	1/4
Max. Working Pressure:	150 PSI
Max. Duty Cycle (@72°F & 100 PSI):	100%
Minutes On/Off (@72°F & 100 PSI):	Continuous
Max. Restart Pressure:	200 PSI
Max. Ambient Temperature:	158°F
Min. Ambient Temperature:	-40°F
Auto. Reset Thermal Protection:	Yes

ADA SYSTEM WIRING SCHEMATIC:

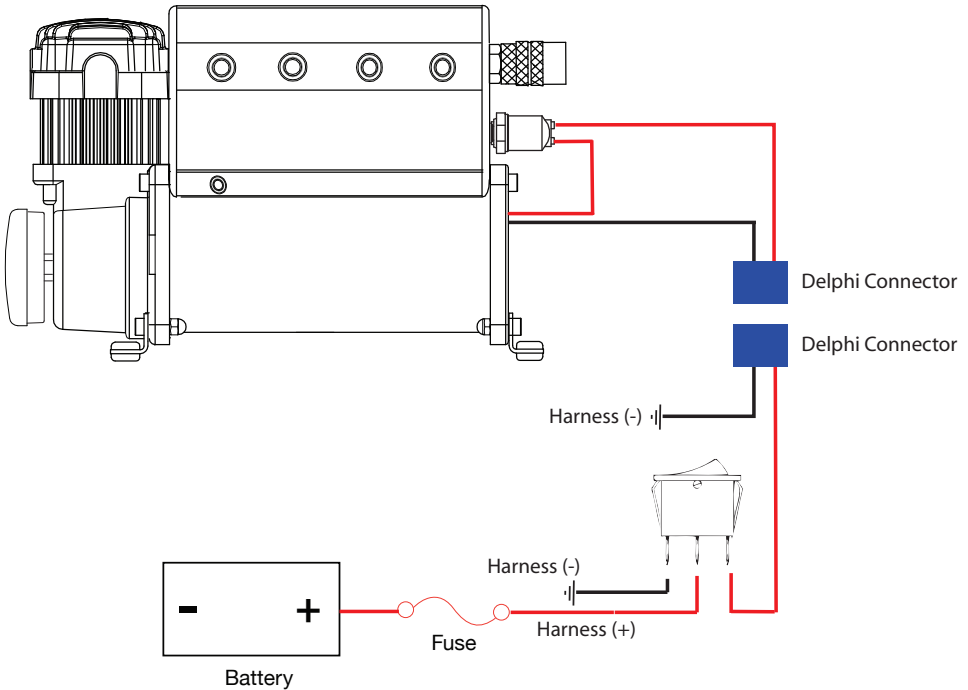

AUTOMATIC DEPLOYMENT AIR SYSTEMS

DIGITAL TIRE INFLATION KIT

The VIAIR Digital Tire Inflation Kit is used for airing up tires, and adding compressed air to any inflatable item with a valve stem. The Digital Tire Inflation Kit has a normally closed lever style air chuck at the end of its rubber hose and comes with a 30' hose. After connection to an air source such as an air tank via the quick connect stud preinstalled in the unit, air may be discharged from the gun by simply squeezing the inflation trigger. To check air pressure, turn on the digital air pressure gauge and select the scale you wish to read (PSI, BAR, KG/CM or kPa) by pressing the "UNIT" button. Release the trigger anytime during inflation to check tire pressure using the digital gauge.

1. USING THE TIRE INFLATION GUN:

To ensure trouble free service life of your compressor, always operate compressor within rated working pressure of the compressor. Never use a pressure switch with a higher cut-off pressure than compressor's rated working pressure.

2. FILLING TIRES AND OTHER INFLATABLE ITEMS:

Squeeze the Inflation Trigger on the Digital Tire Inflation Gun by pressing it towards the handle of the gun. This will allow stored air from the air tank to flow through the gun and through the chuck into your tire or other inflatable.

3. CHECKING TIRE PRESSURE:

To check tire pressure, release Inflation Trigger on Digital Tire Inflation Gun while the gauge is turned on. Tire pressure will be able to be read properly only when the inflation trigger is released.

4. TO TURN UNIT OFF:

After 15 seconds of non-use, the unit will turn off on its own.

5. STORAGE:

Always store using the included deluxe carry bag to protect the inflation gun & hose.

WARNING:

Not intended for use with regular portable compressors (units meant to be operated with an open ended air chuck). The Tire Inflation Gun is equipped with a close-ended chuck (will hold pressure back).

- Never operate the Digital Tire Inflation Gun at any pressure exceeding 180 PSI.
- Use caution when attached or removing air chuck from valve stems.
- Always ensure that tire valve stems are tight before inflating tires.
- Never inflate any tire or other inflatable past its rated pressure to avoid explosion, or possible injury or death.

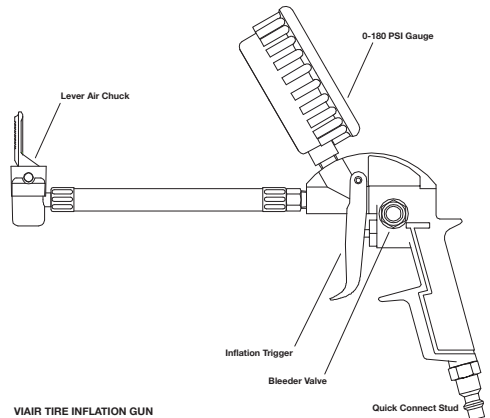

AUTOMATIC DEPLOYMENT AIR SYSTEMS

TROUBLESHOOTING GUIDE:

PROBLEM:	POSSIBLE CAUSE(S)	CORRECTIVE ACTION
Tank pressure drops when compressor(s) shut off	<ol style="list-style-type: none">1. Loose drain cock2. Check valve leaking3. Loose connections	<ol style="list-style-type: none">1. Tighten drain cock2. Replace check valve or compressor(s)3. Check all connections with soap and water solution and tighten
Compressor runs continuously and air flow lower than normal	<ol style="list-style-type: none">1. Excessive air usage2. Loose connections3. Worn piston ring or inlet valve.4. Clogged air filter element	<ol style="list-style-type: none">1. Decrease air usage2. Check all connections with soap and water solution and tighten.3. Replace compressor4. Replace air filter element
Compressor runs continuously causing safety valve (if equipped) to open	<ol style="list-style-type: none">1. Bad pressure switch2. Defective safety valve	<ol style="list-style-type: none">1. Replace pressure switch2. Replace safety valve
Excessive moisture in discharge	<ol style="list-style-type: none">1. Excessive water in air tank2. High humidity	<ol style="list-style-type: none">1. Drain tank, tilt tank to drain. Drain tank more frequently2. Move compressor to area with less humidity, or use air line filter.
Compressor will not run	<ol style="list-style-type: none">1. No power, or power switch in OFF position2. Blown fuse3. Motor overheats4. Pressure switch failure	<ol style="list-style-type: none">1. Make sure compressor switch is ON2. Disconnect compressor(s) from power source, replace fuse. (Refer to Specifications section for correct amperage rating)3. Let compressors cool off for about 30 minutes to allow thermal overload switch to reset.4. Replace pressure switch
Thermal overload protector cuts out repeatedly	<ol style="list-style-type: none">1. Lack of proper ventilation or ambient temperature is too high2. Compressor valves failed	<ol style="list-style-type: none">1. Move compressor to well ventilated area, or area with lower ambient temperature2. Repair or replace compressor
Excessive knocking or rattling	<ol style="list-style-type: none">1. Loose mounting bolts2. Worn bearing on eccentric or motor shaft3. Cylinder or piston ring is worn	<ol style="list-style-type: none">1. Tighten bolts2. Replace bearing or piston assembly3. Replace piston or compressor

CAUTION: NEVER DISASSEMBLE COMPRESSOR WHILE COMPRESSOR IS PRESSURIZED.

AUTOMATIC DEPLOYMENT AIR SYSTEMS

ABOUT COMPRESSOR DUTY CYCLE:

Duty cycle refers to the amount of time a compressor can be operated in a given time period at 100 PSI, and a standard ambient temperature of 72° F. It is commonly expressed in percentage format: $\text{Compressor on time} \div (\text{on time} + \text{off time}) = \text{Duty Cycle \%}$.

ONE-HOUR DUTY CYCLE

(100 PSI @ 72°F)

MINUTES ON / MINUTES OFF

9%	5 Min. On / 55 Min. Off
10%	6 Min. On / 54 Min. Off
15%	9 Min. On / 51 Min. Off
20%	12 Min. On / 48 Min. Off
25%	15 Min. On / 45 Min. Off
30%	18 Min. On / 42 Min. Off
33%	20 Min. On / 40 Min. Off
50%	30 Min. On / 30 Min. Off
100%	1 Hour Run Time

NOTE: All compressors, regardless of rated duty cycle, require sufficient rest time in between cycles to allow for partial or complete heat dissipation. Heat dissipation rates may vary depending on ambient temperatures and operating conditions.

ABOUT RATED WORKING PRESSURE:

To ensure trouble free service life of your compressor, always operate compressor within rated working pressure of the compressor. Never use a pressure switch with a higher cut-off pressure than compressor's rated working pressure.

WIRE GAUGE GUIDE 12-VOLT:

Amp Draw	Length of wire from battery to compressor (in feet)			
	5	10	15	20
5	16	16	16	14
10	16	14	12	10
15	16	12	10	10
20	14	10	10	8
25	14	10	8	6
30	12	10	8	6
40	12	8	6	6
50	10	6	6	4
60	10	6	4	4

WIRE GAUGE GUIDE 24-VOLT:

Amp Draw	Length of wire from battery to compressor (in feet)			
	5	10	15	20
5	16	16	16	16
10	16	16	16	14
15	16	16	14	12
20	16	14	12	10
25	16	12	12	10
30	16	12	10	10
40	14	10	10	8
50	14	10	8	6
60	12	10	8	6



Learn more about wheel and tire service tools we have.