

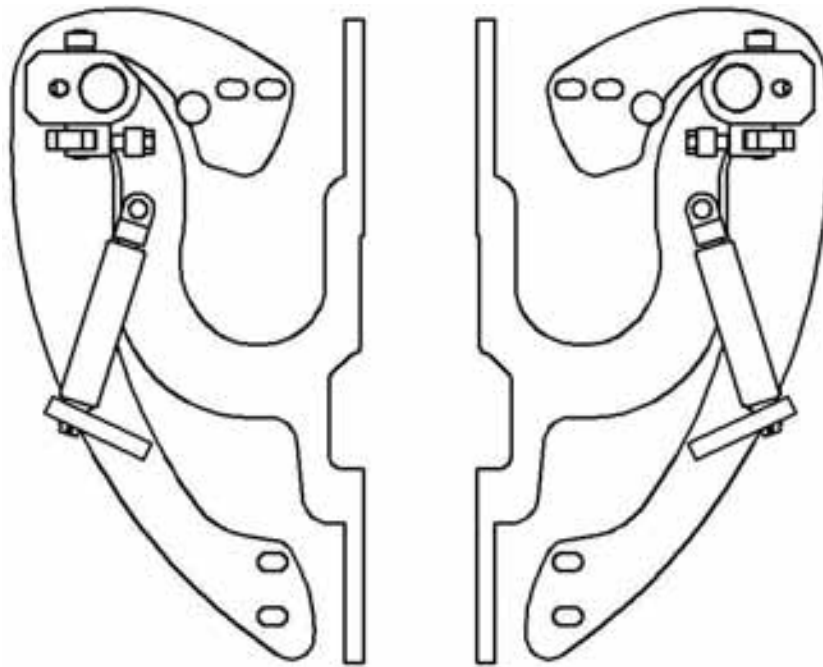

# **SCION TC 2004-2006**

## **INSTRUCTIONS**

US PATENT #6,808,223 & #6,845,547  
AND OTHER PATENTS PENDING



**THIS KIT INCLUDES:**

- 8 M8-1.25X30MM BOLTS WITH WASHERS
- 8 M8-1.25X40MM BOLTS WITH WASHERS
- 2 SHOULDER BOLTS WITH WASHERS
- RIGHT AND LEFT HINGE ASSEMBLY
- 2 SHOCKS 620 PSI
- 2 PINS

**TOOLS REQUIRED FOR INSTALLATION:**

|  |  |
|--|--|
|  | <ul style="list-style-type: none"> <li>➤ AIR RACHET, GRINDER AND CUTTER.</li> </ul>                    |
|  | <ul style="list-style-type: none"> <li>➤ 7MM, 8MM, 10MM, 11MM, 13MM, SOCKETS AND EXTENSION.</li> </ul> |
|  | <ul style="list-style-type: none"> <li>➤ FORK AND PHILLIP'S SCREW DRIVERS</li> </ul>                   |
|  | <ul style="list-style-type: none"> <li>➤ SPACERS FOR THE DOOR GAP.</li> </ul>                          |
|  | <ul style="list-style-type: none"> <li>➤ 3/16 ALLEN WRENCH</li> </ul>                                  |
|  | <ul style="list-style-type: none"> <li>➤ 1/4 TORX BIT</li> </ul>                                       |
|  | <ul style="list-style-type: none"> <li>➤ 9/16 WRENCH</li> </ul>  |
|  | <ul style="list-style-type: none"> <li>➤ LOCKTITE RED</li> </ul>                                       |

**(Note: The pictures on the manual are for reference only they may not match your vehicle.)**

1) Disconnect the battery.

2) Open door completely and remove the door catch that is attached to the inner frame and the door. Remove one 10mm bolt and 2, 10mm nuts. After removing the door catch reinstall the 10mm bolt.



3) Remove Fender.

Remove all plastic clips around the inner fender.

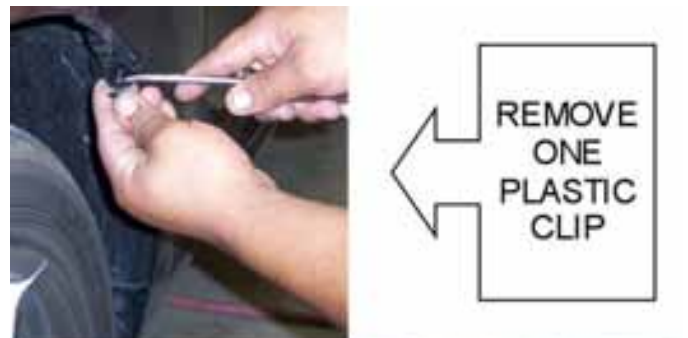





REMOVE ONE 10MM BOLT



REMOVE TWO 10MM BOLTS AND USE THE FORK TO REMOVE THE PLASTIC BRACKET

REMOVE ONE 10MM BOLT



REMOVE THE REMAINING 10MM BOLTS THAT ARE BEHIND THE BRACKET

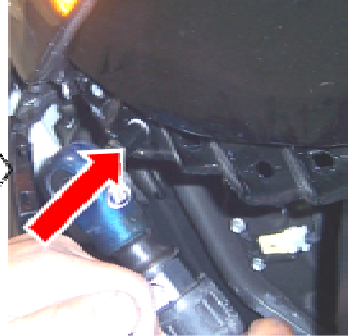

PULL BACK ON SIDE SKIRT, USE THE FORK TO REMOVE THE PLASTIC CLIP TO GAIN ACCESS TO ONE 10MM BOLT



PULL BACK ON THE INNER FENDER AND REMOVE THE FOAM OR PLASTIC THAT COVERS THE HINGE AREA

REMOVE ONE 10MM BOLT



REMOVE ONE 10MM BOLT



CAREFULLY REMOVE THE FENDER FROM ADHESIVE RUBBER BY THE WINDSHIELD

PULL SLIGHTLY UP ON THE TAB TO RELEASE THE FENDER



#### 4) Remove door panel



USE THE PHILLIP'S SCREW DRIVER TO REMOVE 3 SCREWS



PULL ON DOOR PANEL CAREFULLY AND DISCONNECT THE WIRE HARNESS THIS WILL ALLOW YOU TO REMOVE THE DOOR PANEL





5) Extend wires.



6) Remove door catch.



7) Close door and use painters tape to secure the door in preparation for factory hinge removal.

**8) Remove factory hinges, and install door spacers**

*Hint\* (You can make your spacer out of paint sticks and about 8-10 turns of blue painters tape)*

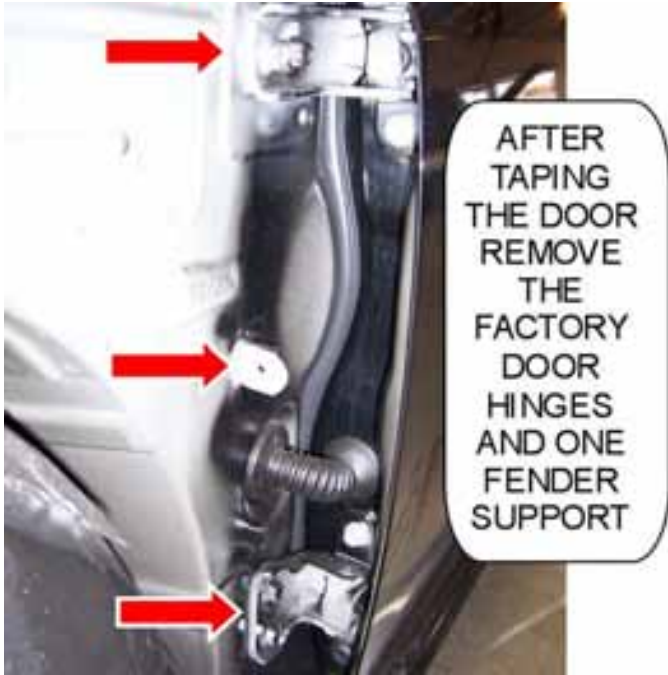

**9) Install new hinge in place making sure it is flat against all contact surface, insert new bolts on firewall side and factory bolts on door side. Once the new vertical door hinge is secure remove the painter's tape.**

*Hint\*(When locking hinge in place tighten bolts to door first then firewall bolts second)*





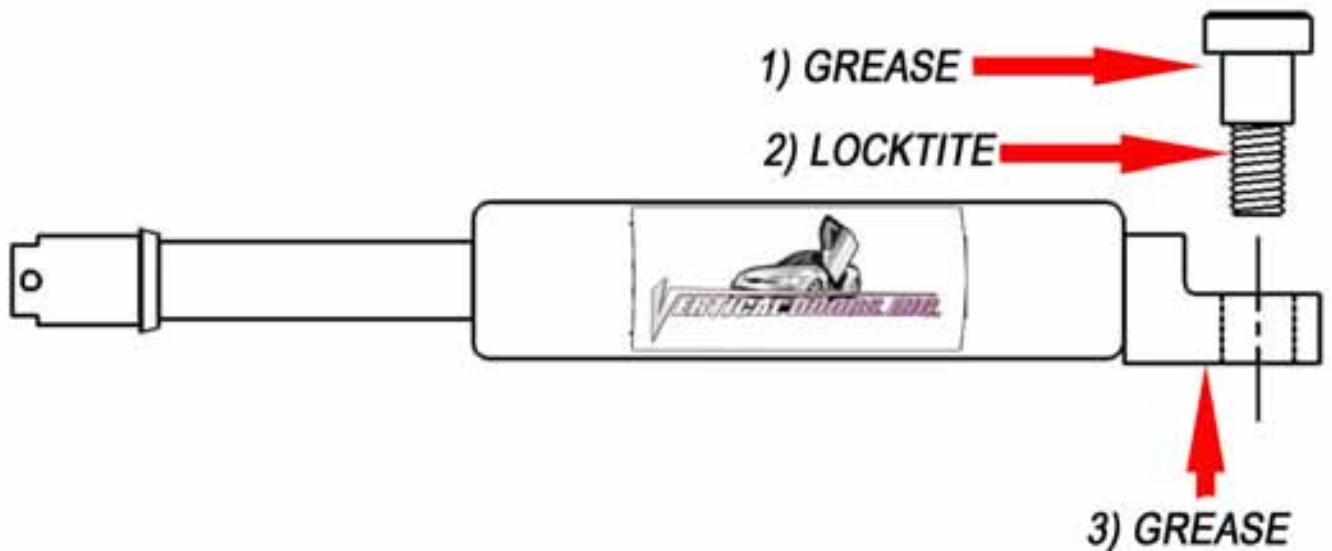

***\*IMPORTANT STEP: DO NOT SKIP THIS STEP. THIS STEP IS CRUCIAL IN YOUR INSTALLATION PROCESS, IF THIS STEP IS NOT COMPLETED WHEN INSTALLING THE VERTICAL DOOR KIT; ALL WARRANTIES ARE VOIDED, AND MAY CAUSE FUTURE PROBLEMS WITH YOUR VERTICAL DOOR SYSTEM.***

*1ST, make sure you put grease on the body of shoulder bolt where the arrow is pointing.*

*2ND, make sure you put red Loctite, where the arrow is pointing, on thread of shoulder bolt.*

*3RD, make sure you put grease on the bottom side of the shock end.*



***WARNING! THE USE OF ANY TYPE PLYERS, PAINT OR FOREING MATERIALS ON THE SHOCK'S BODY OR SHAFT WILL VOID THE WARRANTY.***



**10)** Once hinge is locked in place, break nut #1 then turn Allen set screw #2 on fig until it hits the block then open the door and continue to adjust until the door matches with the striker, open and close door making sure it closes like factory.

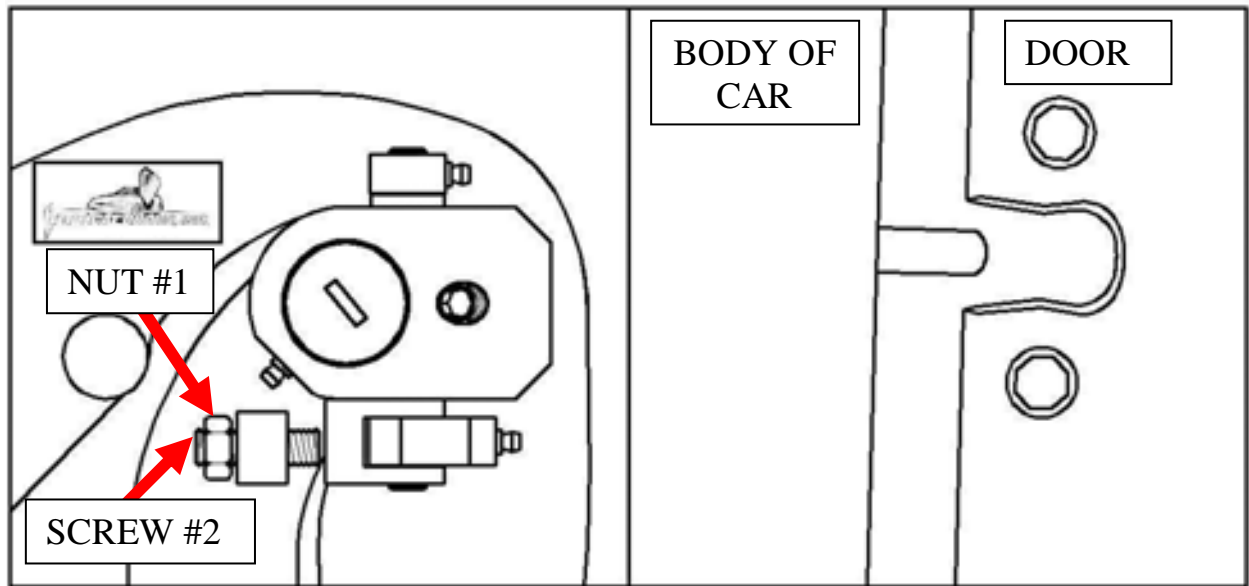

*Hint\**(leave #1 nut loose until shock is installed Allen set screw will have to be re-adjusted after shock is installed).

**11)** Install the shock.

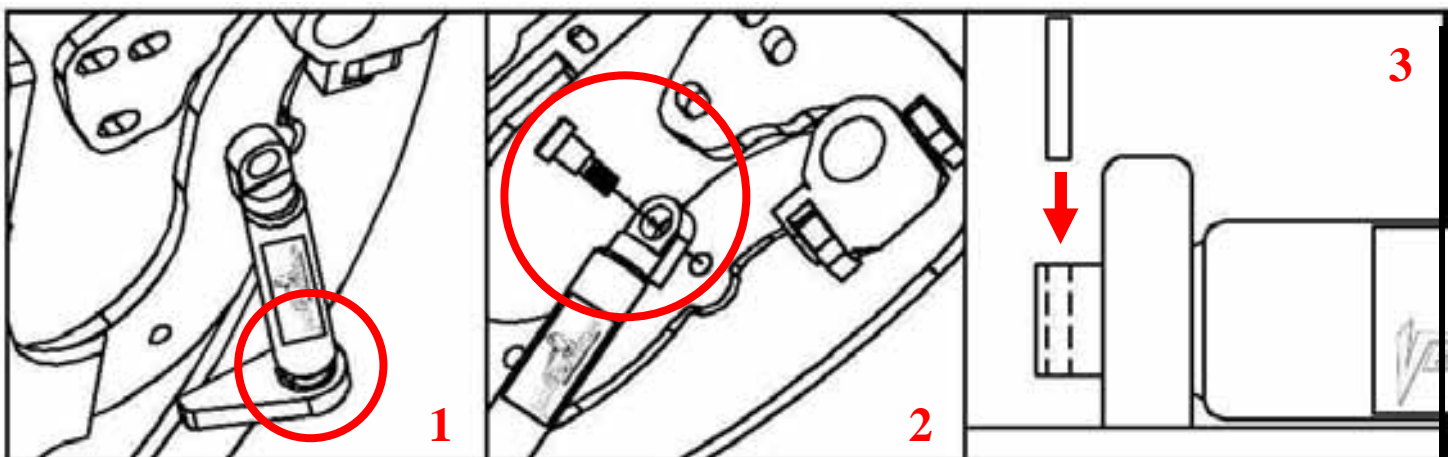

*Hint\** (You will need a helper to raise the door). (Slip the spherical rod mount into the spherical ball bearing (1). Using a 1/4 Allen wrench, tighten the screw into the swing arm (2). After the shock is installed secure it by installing the pin in the bottom shock end (3).

**12)** After shock is installed re-install door panel and lift the door. Adjust door opening screw #3 clockwise until distance between nub and swing arm is enough so that the swing arm moves up and down freely.

*Hint\* (Fine tune the Allen Adjustment screw (#2) to realigned striker with door. After the door is align test door by opening and closing, lifting and lowering door several times.*

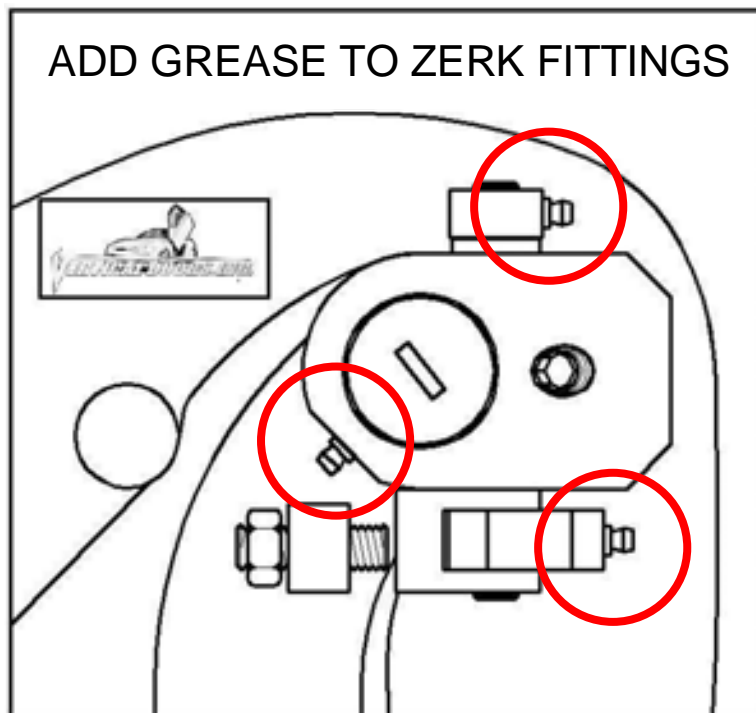
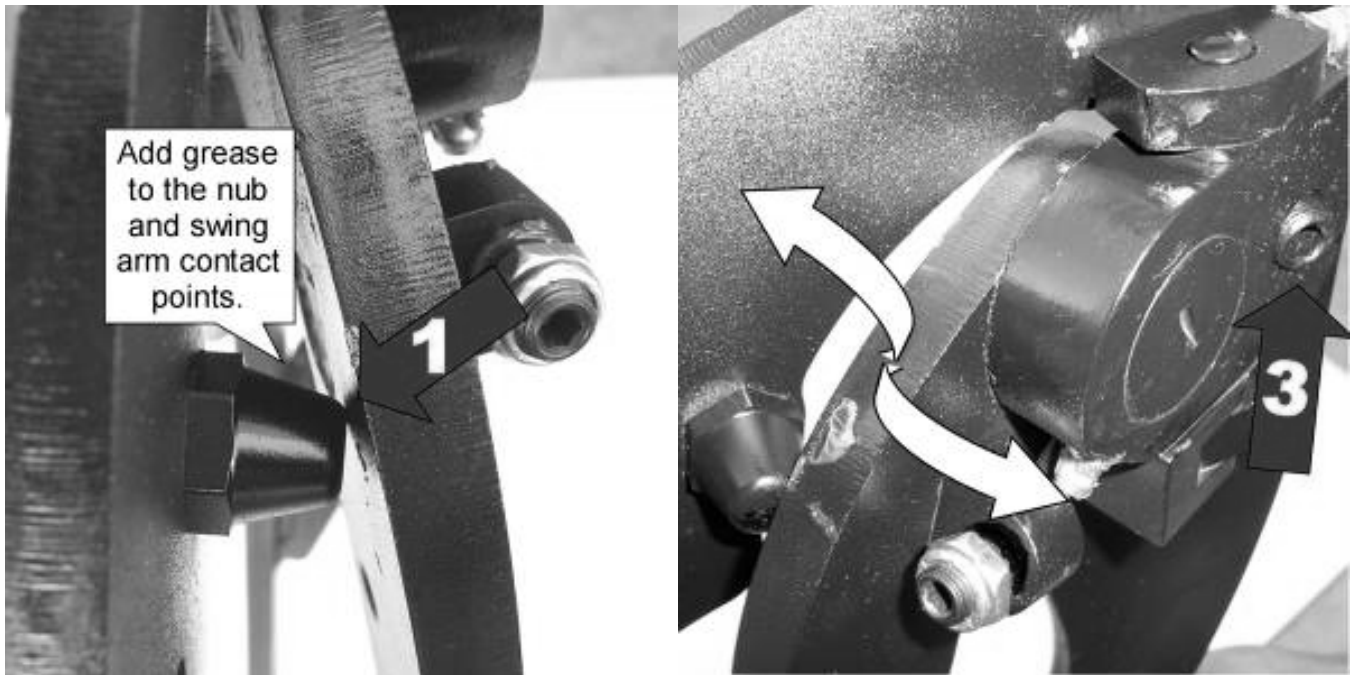

**Note:** Do not install fender until the adjustment of the door is accurate, and the set screw is tightly secure. Also make sure everything is tight, adjustment is set and everything is Locktite.



**13)** You will have to cut the inner lip of your fender to make room for the new Vertical Doors hinge.



**14)** Close the door and Replace the fender by reversing step 3

*Hint\*(Make sure the electrical wires don't get pinched enough to damage wires)*

**15)** For the other side just follow steps 2-14.