

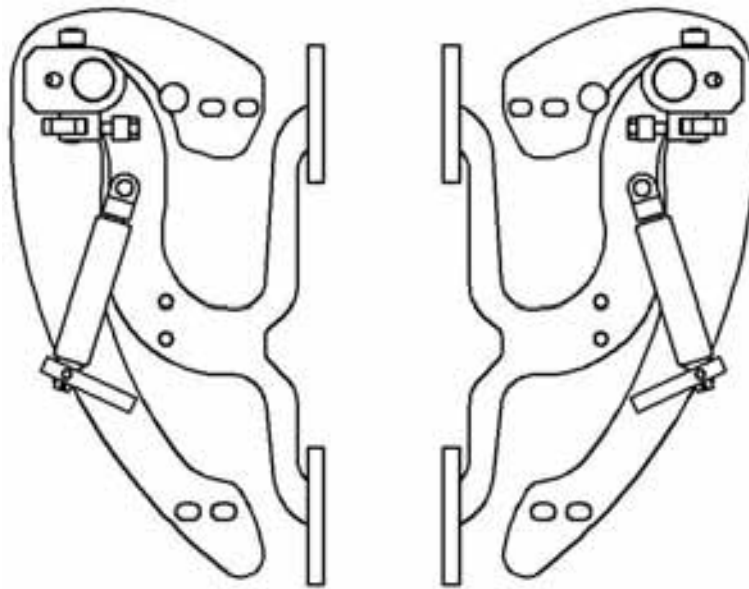

2000-2005

INSTRUCTIONS

US PATENT #6,808,223 & #6,845,547



THIS KIT INCLUDES:

➤ 16 M8-1.25X40MM BOLTS WITH WASHERS	➤ RIGHT AND LEFT HINGE ASSEMBLY
➤ 2 SHOCKS 720 PSI	➤ 2 SHOULDER BOLTS
➤ 2 PINS	

TOOLS REQUIRED FOR INSTALLATION:

	➤ AIR RACHET, GRINDER AND CUTTER.
	➤ 10MM, 11MM, 13MM, 14MM, 15MM, SOCKETS AND EXTENSION.
	➤ FORK AND PHILLIP'S SCREW DRIVERS
	➤ SPACERS FOR THE DOOR GAP.
	➤ 3/16 ALLEN WRENCH
	➤ 1/4 TORX BIT
	➤ 9/16 WRENCH
	➤ LOCKTITE RED

OTHER TOOLS MAY BE NEEDED DEPENDING ON YOUR VEHICLE.

(Note: The pictures on the manual are for reference only they may not match your vehicle.)

1) Disconnect the battery.

2) Loosen door catch.

Loosen the bolts securing the door catch. Later on we'll remove it.



3) Remove the headlight:

Open the hood and remove (3) 10mm bolts securing the headlight to the body. After removing the bolts pull straight up on the headlight and disconnect the wire harness.



4) Remove fender:

Remove all the fasteners around the wheel well.



Pull on the wheel well and remove (1) 10mm bolt then move to the hole where the headlight was and remove the bolts securing the fender to the bumper and the chassis.



On the back of the wheel well (closest to the door) remove (2) Phillips screw located under the skirt. This will allow you to pull on it and remove (2) 10mm bolts securing the fender to the body.



Open the door and remove one 10mm screw located at the bottom of the windshield pillar.

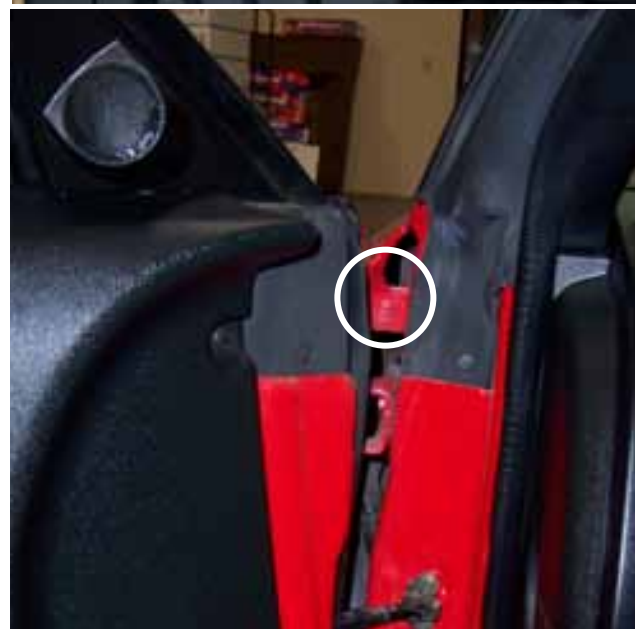

Remove all the bolts from the top of the fender.

Now you will be able to carefully remove the fender.



5) Remove Door panel:

Use the fork to help you remove the covers and the Phillip's screwdriver to remove the screws.

Use the fork to remove the control panel and disconnect the (2) wire harnesses.

Carefully remove the door panel. Some models may have a light at the bottom left corner of the door, as you are pulling the door panel you will have to disconnect it.



While the door panel is off the car, remove the speaker this will allow you to remove the door catch and the (3) plastic clips that hold the wires in place.



After gaining the extra wire slack use zip ties to keep the wires away from the window mechanism.

Now replace the door panel.

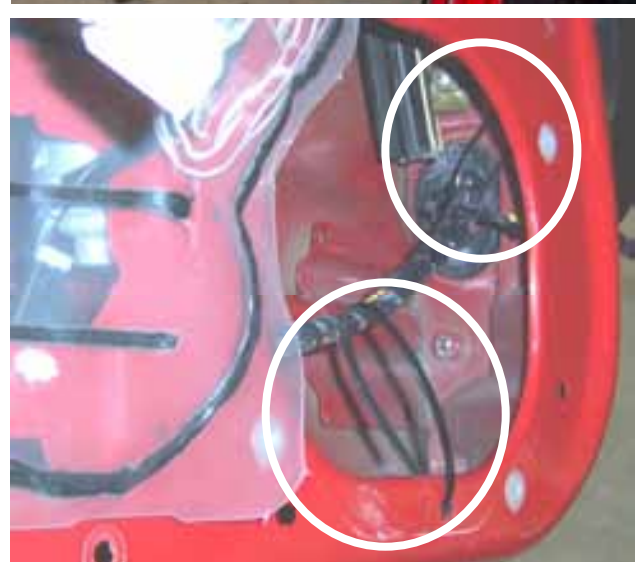

6) Close door and use painter's tape to secure the door in preparation for factory hinge removal.

Use a 13mm socket to remove the factory hinges.

Hint (You can make your spacer out of paint sticks and about 8-10 turns of blue painters tape)*



Install the spacers after the factory hinges have been removed.

7) Install new Vertical Doors Inc. system:

To make sure the surface is completely flat; you will have to modify the area where the new Vertical Doors Inc. system will be installed. Remove (1) clip securing the wires to the apron and push the wires under the apron as showed on the bottom right picture, place the new VDI in place, mark the area that will be modify, remove the hinge and cut the small are that was mark and bend it with a hammer until the hinge sits flat on the apron.



After bending the notch on the apron you will be able to install the new VDI system.

Hint Tighten the bolts on the door first then the bolts on the body.*

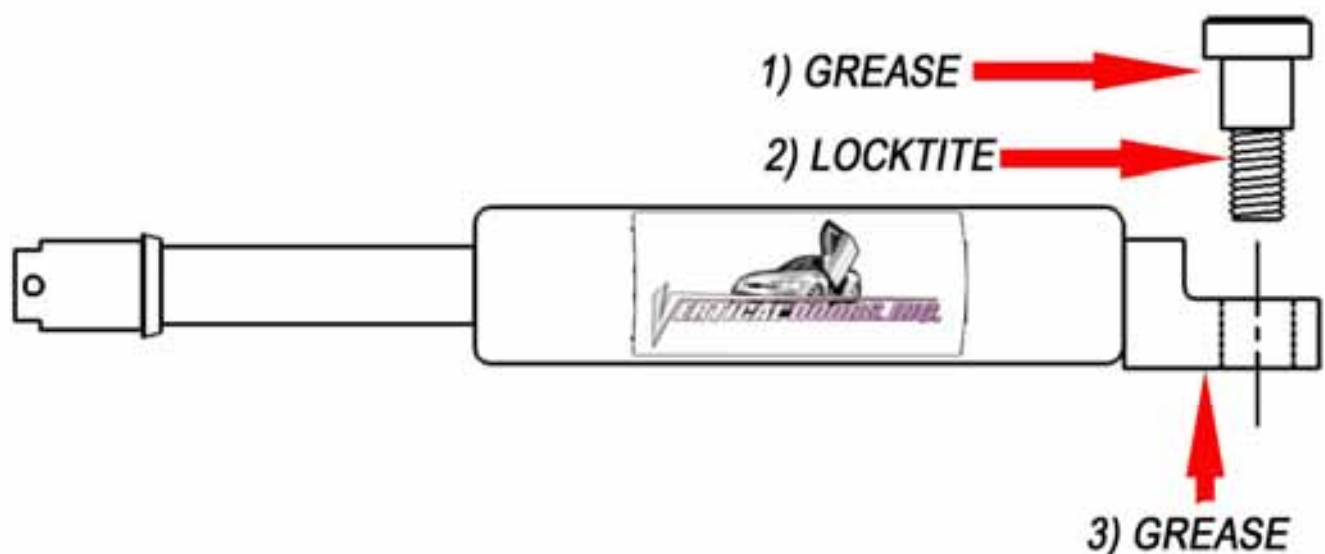

***IMPORTANT STEP: DO NOT SKIP THIS STEP. THIS STEP IS CRUCIAL IN YOUR INSTALLATION PROCESS, IF THIS STEP IS NOT COMPLETED WHEN INSTALLING THE VERTICAL DOOR KIT; ALL WARRANTIES ARE VOIDED, AND MAY CAUSE FUTURE PROBLEMS WITH YOUR VERTICAL DOOR SYSTEM.**

1ST, make sure you put grease on the body of shoulder bolt where the arrow is pointing.

2ND, make sure you put red Loctite, where the arrow is pointing, on thread of shoulder bolt.

3RD, make sure you put grease on the bottom side of the shock end.



WARNING! THE USE OF ANY TYPE PLYERS, PAINT OR FOREING MATERIALS ON THE SHOCK'S BODY OR SHAFT WILL VOID THE WARRANTY.

8) Once hinge is locked in place, break nut #1 then turn Allen set screw #2 on fig until it hits the block then open the door and continue to adjust until the door matches with the striker, open and close door making sure it closes like factory.

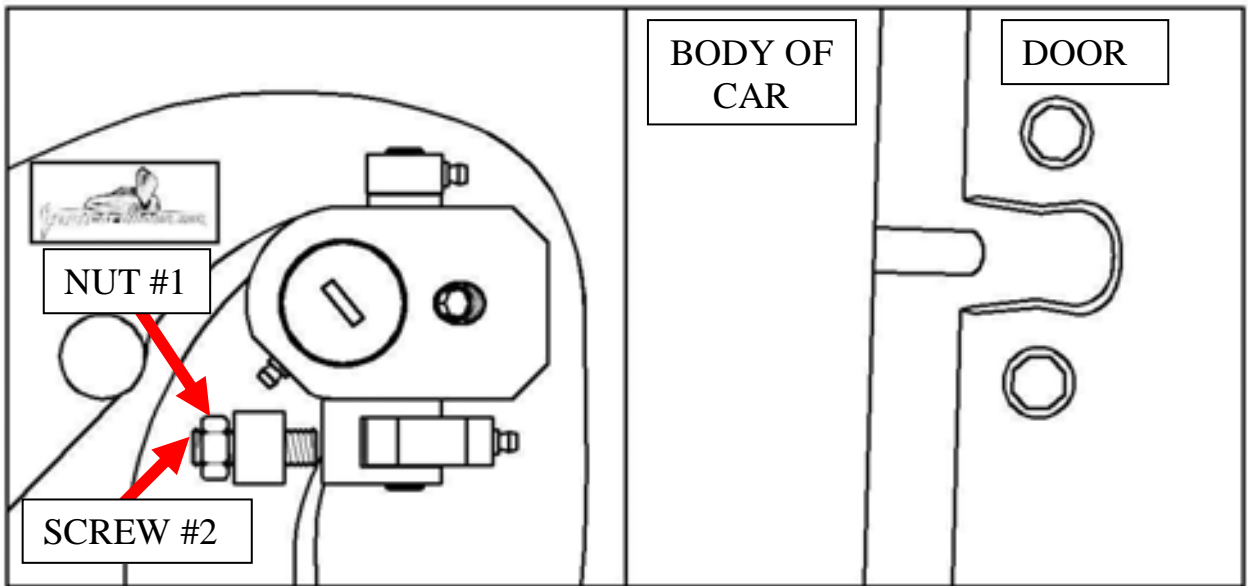

*Hint**(leave #1 nut loose until shock is installed Allen set screw will have to be re-adjusted after shock is installed).

9) Install the shock.

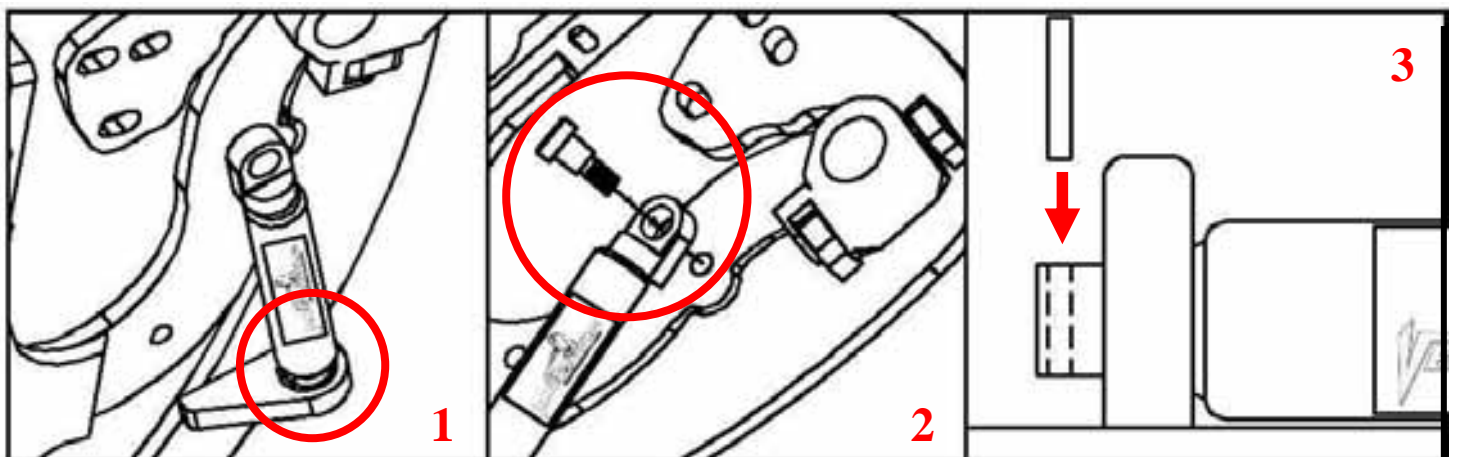

*Hint** (You will need a helper to raise the door). (Slip the spherical rod mount into the spherical ball bearing (1). Using a 1/4 Allen wrench, tighten the screw into the swing arm (2). After the shock is installed secure it by installing the pin in the bottom shock end (3).

10) After shock is installed re-install door panel and lift the door. Adjust door opening screw #3 clockwise until distance between nub and swing arm is enough so that the swing arm moves up and down freely.

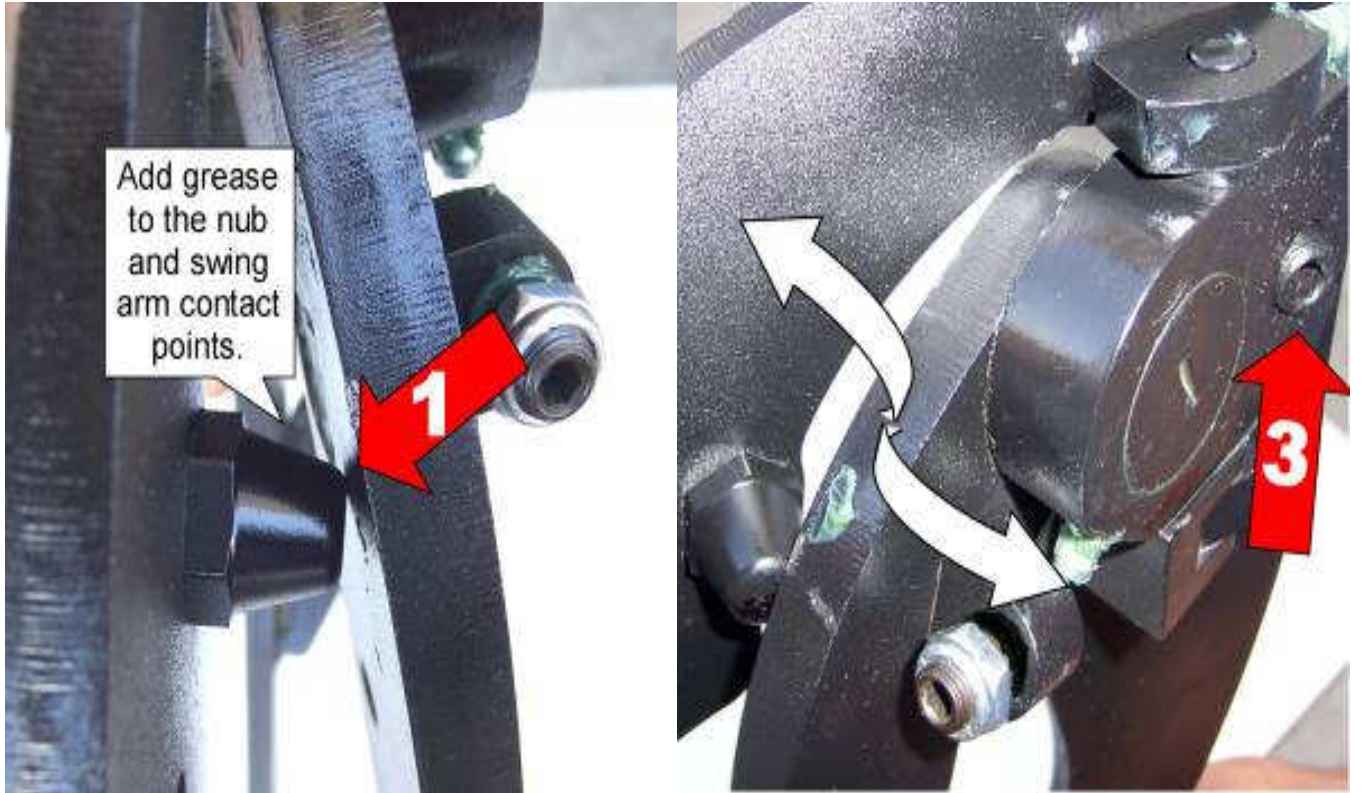

Hint (Fine tune the Allen set screw (#2) to realigned sticker with door. After the door is aligned, test door by opening and closing, lifting and lowering door several times.*

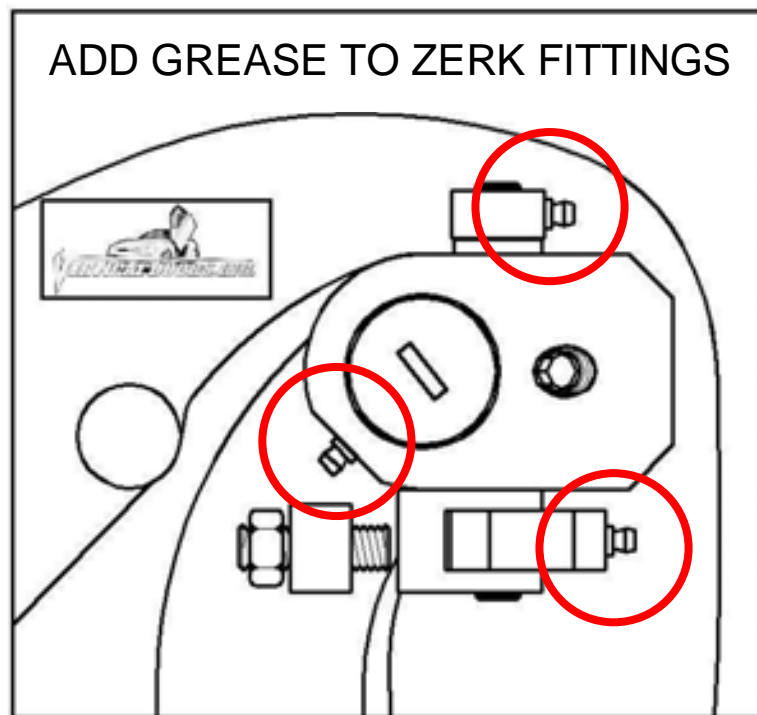

Note: Do not install fender until the adjustment of the door is accurate, and the set screw is tightly secure. Also make sure everything is tight, adjustment is set and everything is Locktite.

11) Modify factory wire loom.

You will have to open and raise the door, cut the factory wire loom in half and add included wire loom to protect exposed wires.

Your wires should look like the picture on the right.



12) Cut the inner lip of your fender to make room for the new Vertical Doors hinge. Note: After you have cut the fender use a sander or grinder and take out any sharp edges, use black door trim to give it a finish look.



13) Close the door and Replace the fender by reversing step 3.

Hint(Make sure the electrical wires don't get pinched enough to damage wires)*

14) For the other side just follow steps 2-13.