



2003-2005

INSTRUCTIONS

US PATENT #6,808,223 & #6,845,547



THIS KIT INCLUDES:

- 12 M8-1.25X40MM BOLTS WITH WASHERS
- 8 M8-1.25X30MM BOLTS WITH WASHERS
- RIGHT AND LEFT HINGE ASSEMBLY
- 2 SHOCKS 720 PSI
- 2 SHOULDER BOLTS WITH WASHERS
- 2 PINS

TOOLS REQUIRED FOR INSTALLATION:

	<ul style="list-style-type: none"> ➤ AIR RACHET, GRINDER AND CUTTER.
	<ul style="list-style-type: none"> ➤ 7MM, 8MM, 10MM, 11MM, 13MM, SOCKETS AND EXTENSION.
	<ul style="list-style-type: none"> ➤ FORK AND PHILLIP'S SCREW DRIVERS
	<ul style="list-style-type: none"> ➤ SPACERS FOR THE DOOR GAP.
	<ul style="list-style-type: none"> ➤ 3/16 ALLEN WRENCH
	<ul style="list-style-type: none"> ➤ 1/4 TORX BIT
	<ul style="list-style-type: none"> ➤ 9/16 WRENCH
	<ul style="list-style-type: none"> ➤ LOCKTITE RED

OTHER TOOLS MAY BE NEEDED DEPENDING ON YOUR VEHICLE.

(Note: The pictures on the manual are for reference only they may not match your vehicle.)

1) Disconnect the battery.

2) Remove fender. Using the fork screwdriver remove all plastic clips that hold the splash guard to fender.

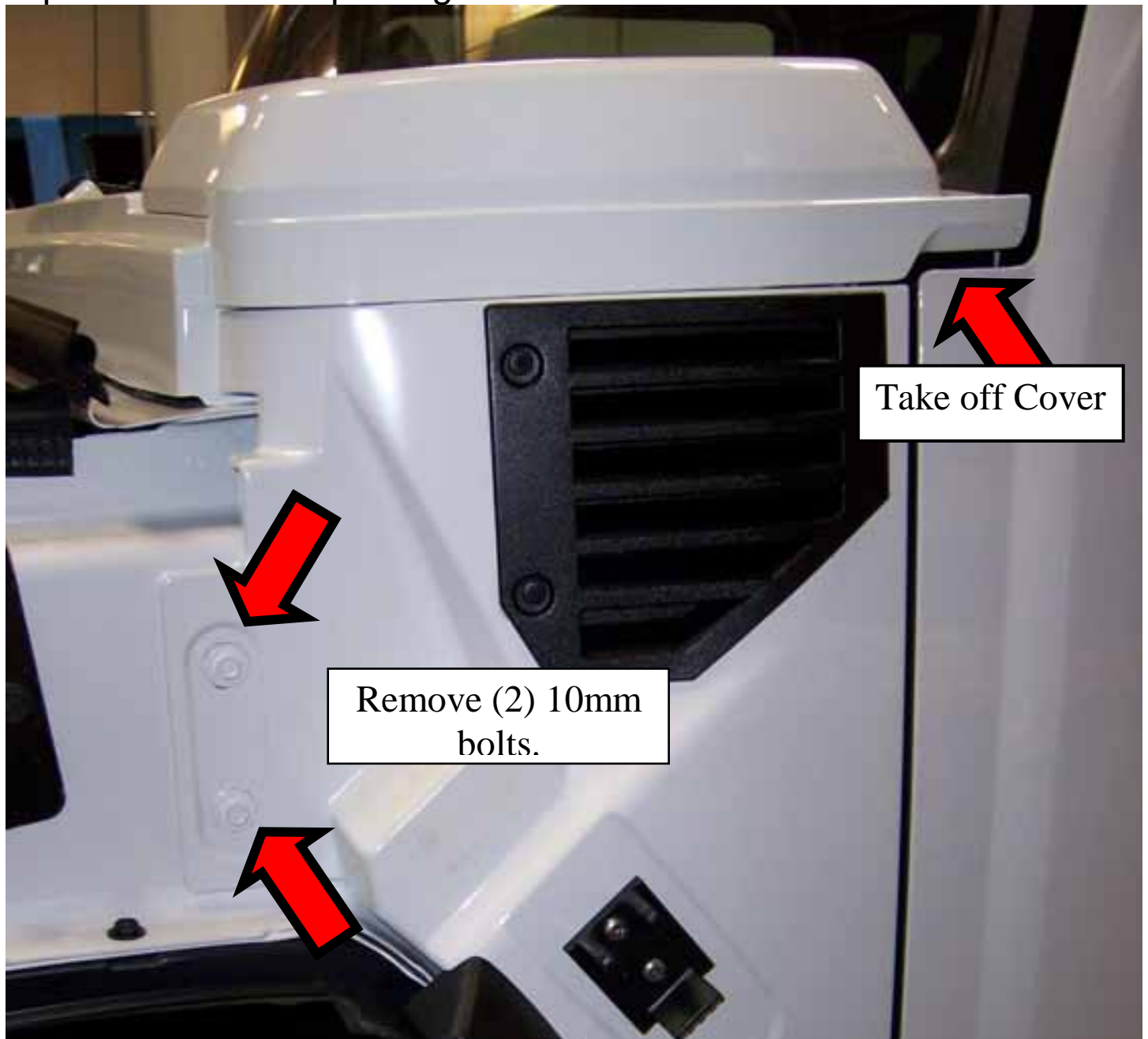

Remove, (3) torque screws and (1) plastic clip. There is also one plastic clip by the bottom of the door. After all fasteners have been removed; (1) 10mm nut will be exposed you will have to remove it.

Remove (1) 10mm bolt.

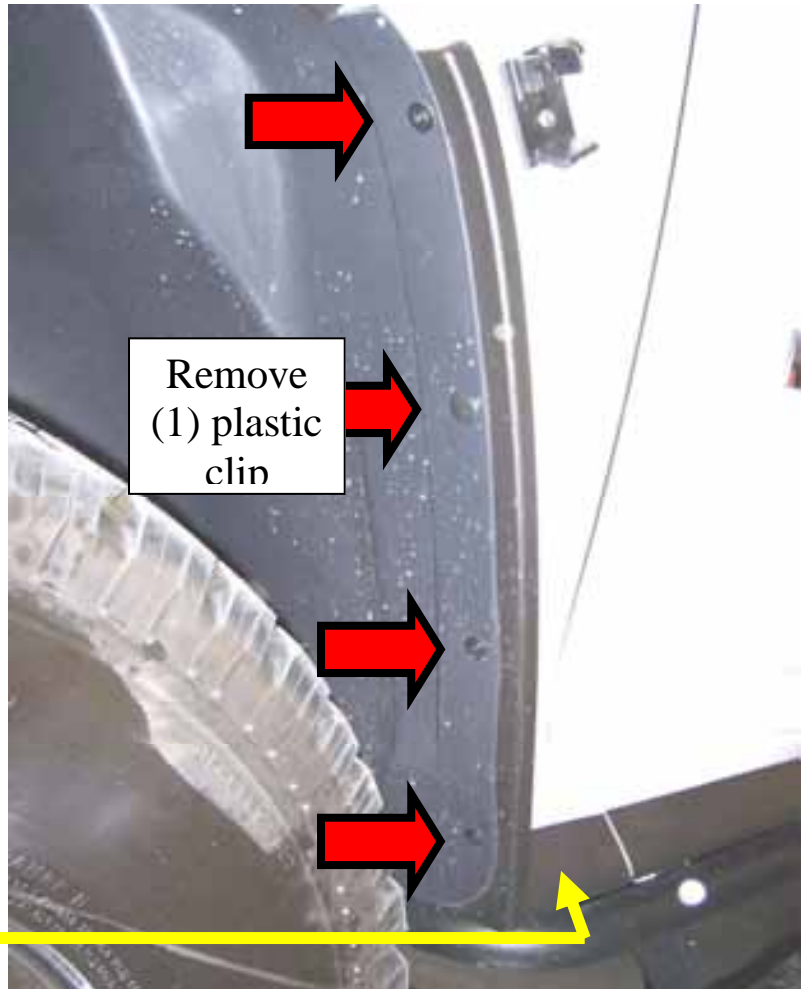

Open the door and remove (2) 10mm bolts that hold the fender to the body.

Also remove the door catch.

At this time you should be able to remove the fender.

Remove the plastic door trim.



3) Door panel removal:
Remove the door panel by taking off the handle cover; you will find (2) 7mm screws, remove them and pull the panel off. Remove the door catch and reinstall the door panel.



4) Tape up the door. Use blue painter's tape to secure the door to the body.



5) Prepare area for the new Vertical Doors Inc. system.
Remove the factory door hinges, tape up and cut the bump
where the new Vertical Doors Inc system will be placed.

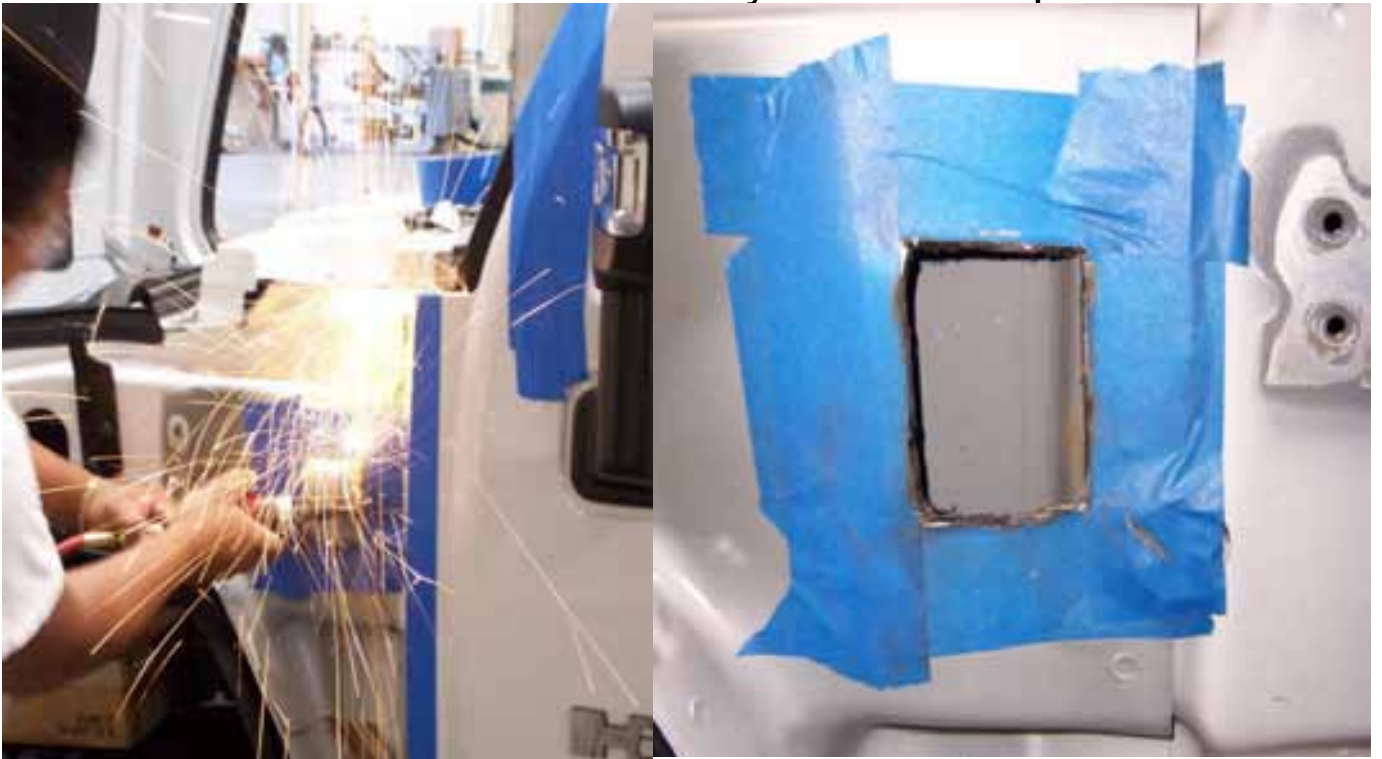

6) Install spacers
before the new
Vertical Doors Inc.
system.



7) Install the new Vertical Doors Inc. system.

Make sure it's flat against all surfaces.



*HINT:**
Tighten the bolts on the door first and then the bolts on the body.

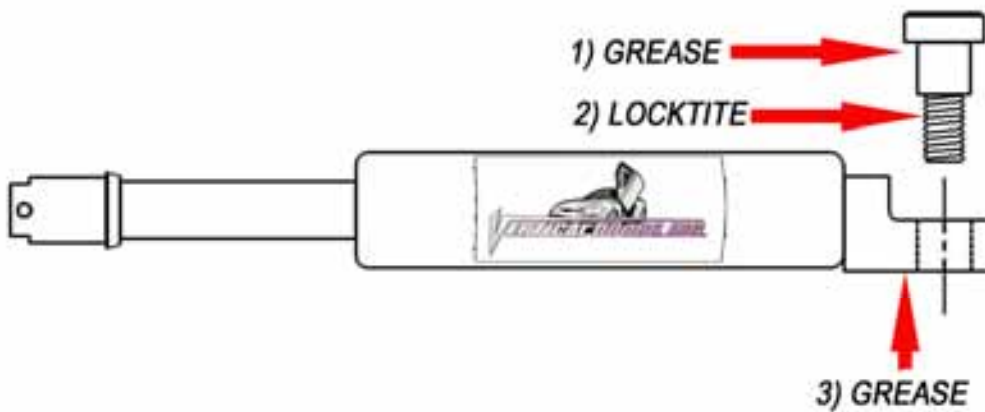

***IMPORTANT STEP: DO NOT SKIP THIS STEP. THIS STEP IS CRUCIAL IN YOUR INSTALLATION PROCESS, IF THIS STEP IS NOT COMPLETED WHEN INSTALLING THE VERTICAL DOOR KIT; ALL WARRANTIES ARE VOIDED, AND MAY CAUSE FUTURE PROBLEMS WITH YOUR VERTICAL DOOR SYSTEM.**

1ST, make sure you put grease on the body of shoulder bolt where the arrow is pointing.

2ND, make sure you put red Locktite, where the arrow is pointing, on thread of shoulder bolt.

3RD, make sure you put grease on the bottom side of the shock end.



WARNING! THE USE OF ANY TYPE PLYERS, PAINT OR FOREING MATERIALS ON THE SHOCK'S BODY OR SHAFT WILL VOID THE WARRANTY.

8) Once hinge is locked in place, break nut #1 then turn Allen set screw #2 until it hits the block then open the door and continue to adjust until the door matches with the striker, open and close door making sure it closes like factory.

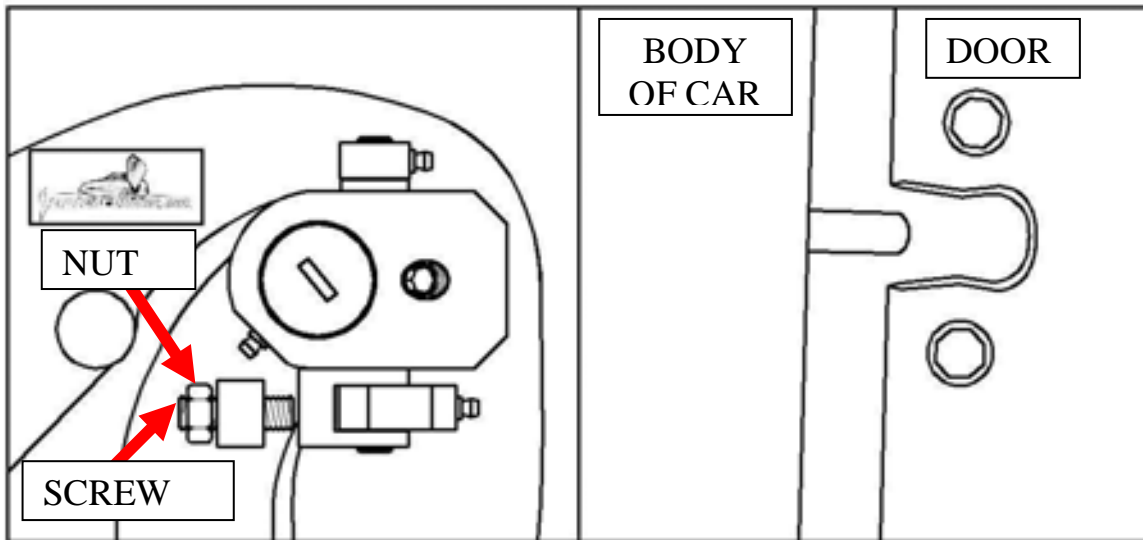

Hint (leave #1 nut loose until shock is installed Allen set screw will have to be re-adjusted after shock is installed).*

9) Install the shock.

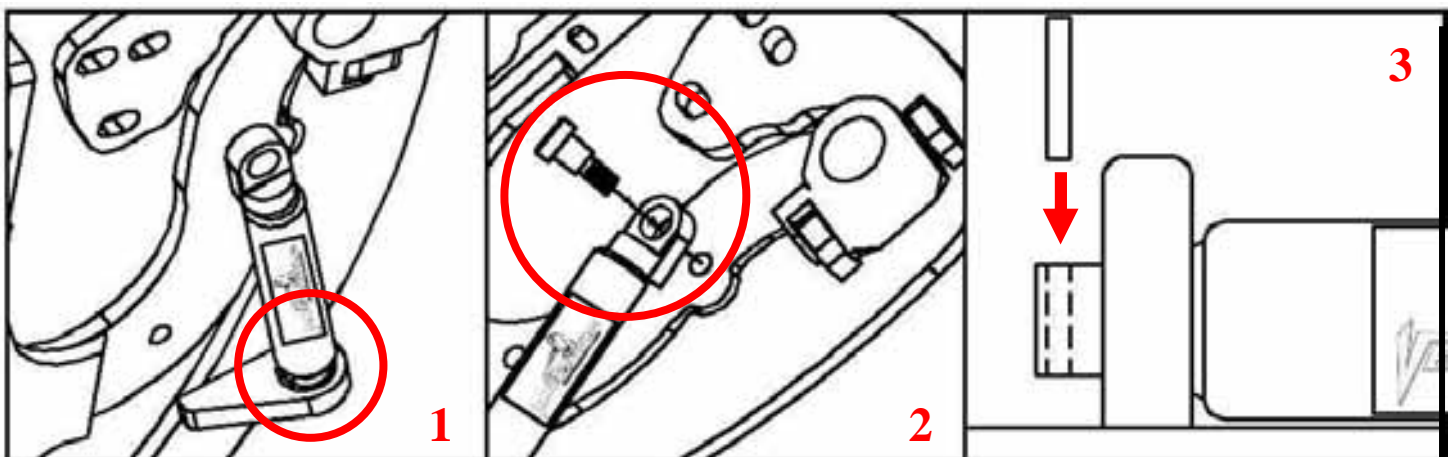

Hint (You will need a helper to raise the door). (Slip the spherical rod mount into the spherical ball bearing (1). Using a 1/4 Allen wrench, tighten the screw into the swing arm (2). After the shock is installed secure it by installing the pin in the bottom shock end (3).*

10) After shock is installed re-install door panel and lift the door. Adjust door opening screw #3 clockwise until distance between nub and swing arm is enough so that the swing arm moves up and down freely.

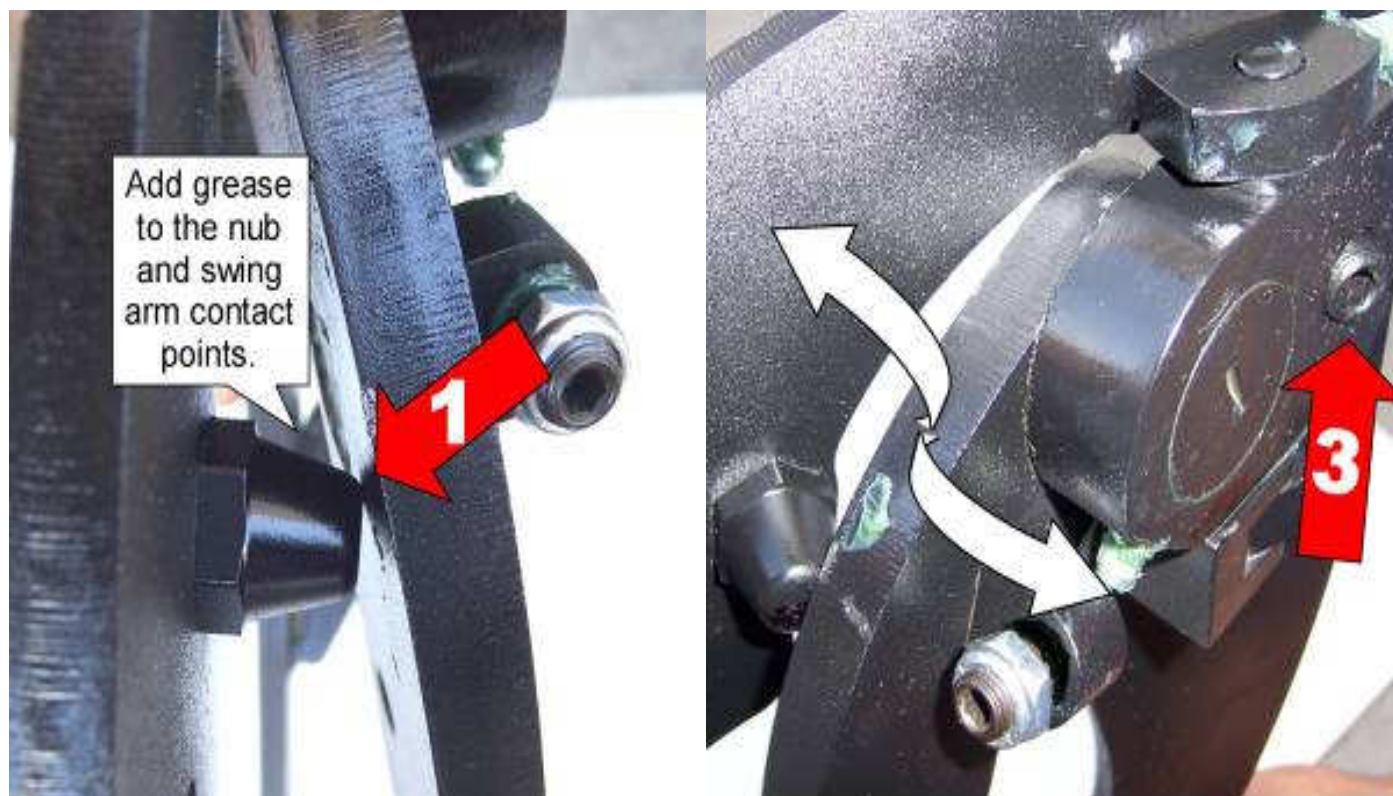

Hint (Fine tune the Allen set screw (#2) to realigned striker with door. After the door is aligned, test door by opening and closing, lifting and lowering door several times.*

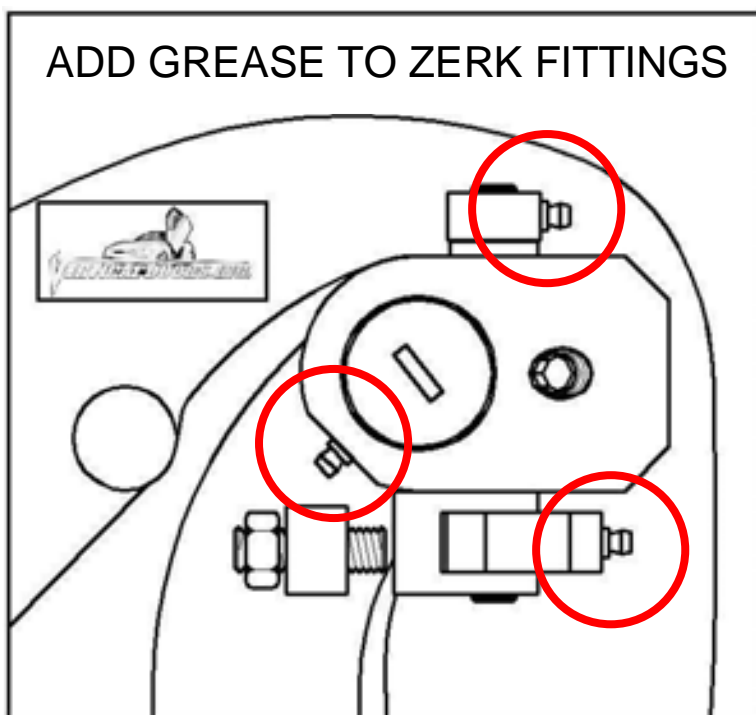

Note: Do not install fender until the adjustment of the door is accurate, and the set screw is tightly secure. Also make sure everything is tight, adjustment is set and everything is Locktite.

11) Modify wire layout. Cut the Factory wire loom in half to gain extra slack on the wires and use Black electrical tape to protect the exposed wires.



12) Cut the inner lip of your fender to make room for the new Vertical Doors Inc. system.

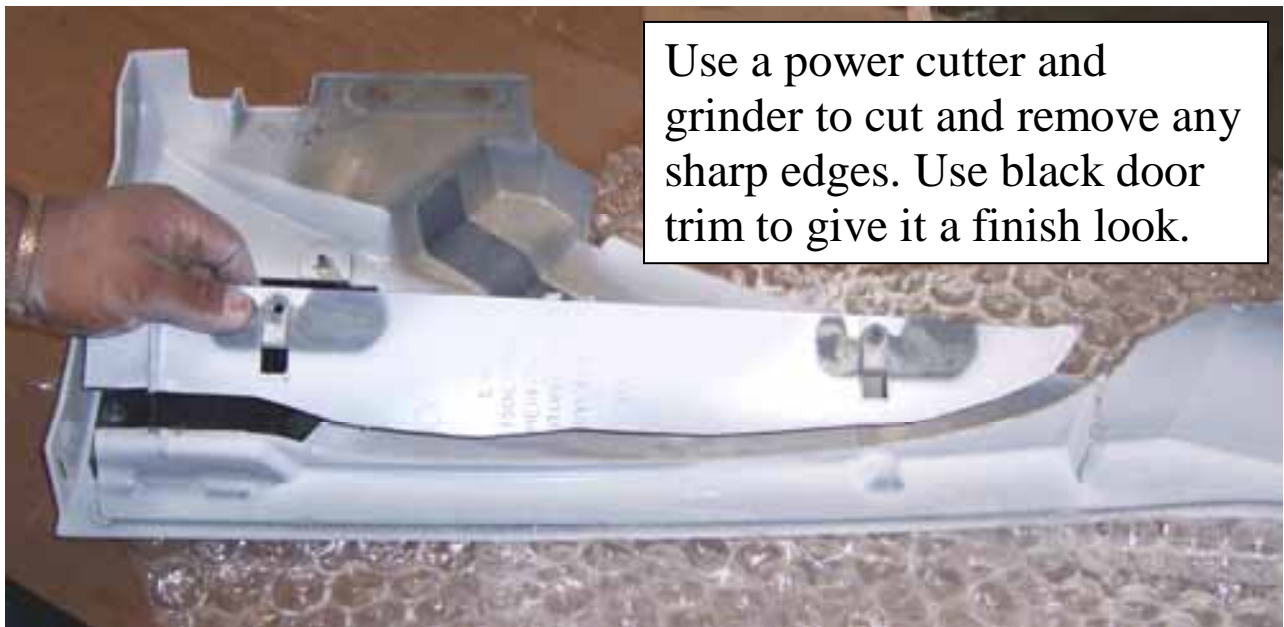

Use a power cutter and grinder to cut and remove any sharp edges. Use black door trim to give it a finish look.

13) Lift the door and Replace the fender by reversing step 2.

Hint(Make sure the electrical wires don't get pinched enough to damage wires)*

14) For the passenger side just follow steps 2-12, with a couple of changes. Remove antenna and antenna bracket.

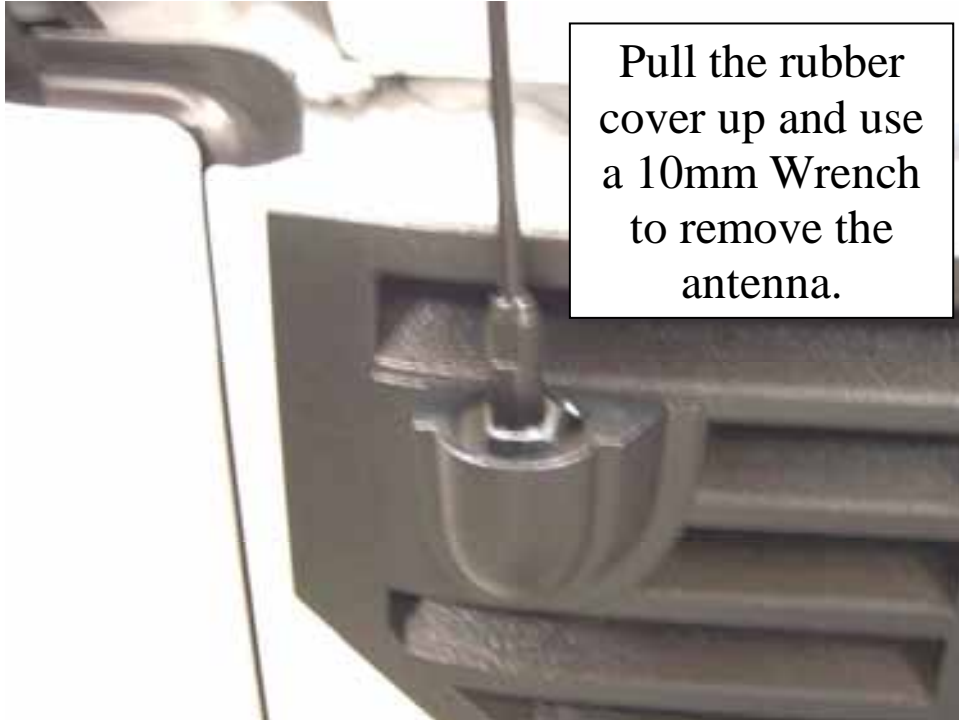

Remove and cut the antenna bracket. Replace it after it has been cut.

