

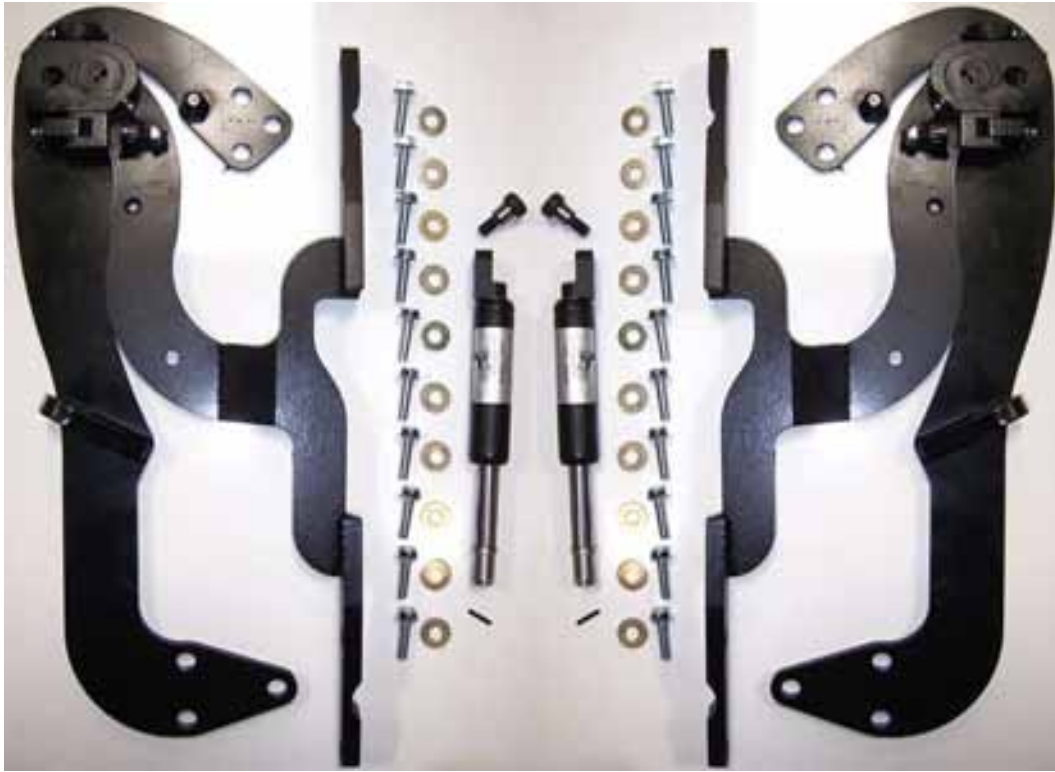

FORD F-150 97-02

INSTRUCTIONS









US PATENT #6,808,223 & #6,845,547

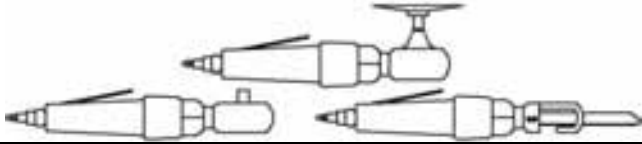

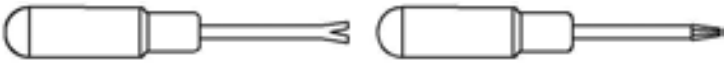
THIS KIT INCLUDES:

- 20 M8-1.25X30MM BOLTS WITH WASHERS
- 2 SHOULDER BOLTS WITH WASHERS
- 2 PINS
- RIGHT AND LEFT HINGE ASSEMBLY
- 2 SHOCKS 720 PSI

TOOLS REQUIRED FOR INSTALLATION:

| | |
|---|--|
|  | <ul style="list-style-type: none"> ➤ AIR RACHET, GRINDER AND CUTTER. |
|  | <ul style="list-style-type: none"> ➤ 7MM, 8MM, 10MM, 11MM, 13MM, SOCKETS AND EXTENSION. |
|  | <ul style="list-style-type: none"> ➤ FORK AND PHILLIP'S SCREW DRIVERS |
|  | <ul style="list-style-type: none"> ➤ SPACERS FOR THE DOOR GAP. |
|  | <ul style="list-style-type: none"> ➤ 3/16 ALLEN WRENCH |
|  | <ul style="list-style-type: none"> ➤ 1/4 TORX BIT |
|  | <ul style="list-style-type: none"> ➤ 9/16 WRENCH |
|  | <ul style="list-style-type: none"> ➤ LOCKTITE RED |

OTHER TOOLS MAY BE NEEDED DEPENDING ON YOUR VEHICLE.

(Note: The pictures on the manual are for reference only they may not match your vehicle.)

1) Disconnect the battery.

2) Remove head lights.

Use the fork screwdriver to remove the signal light.

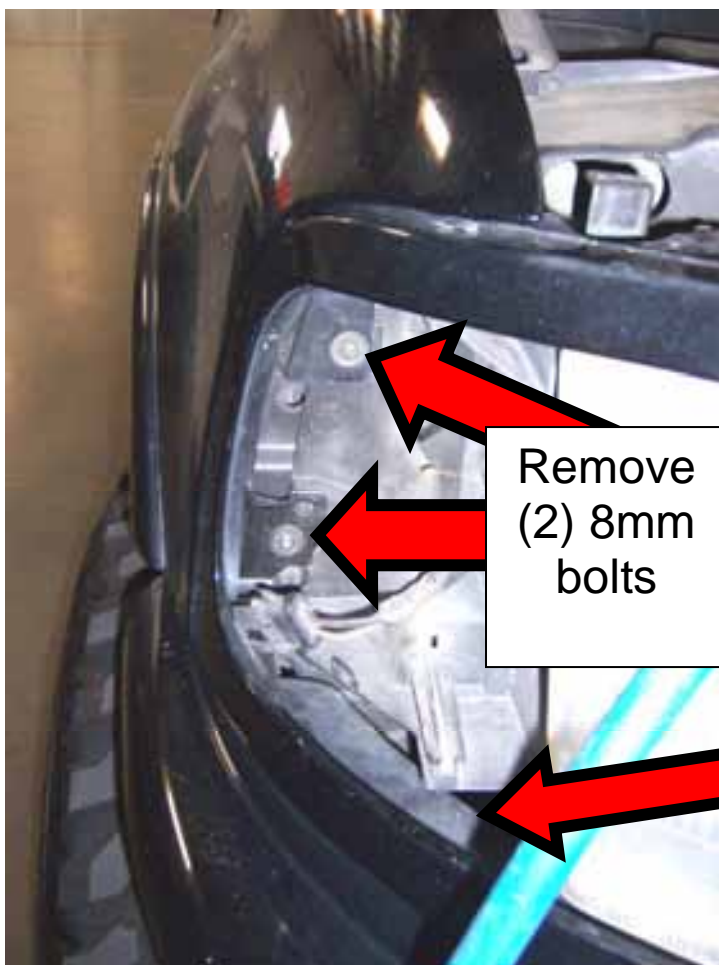
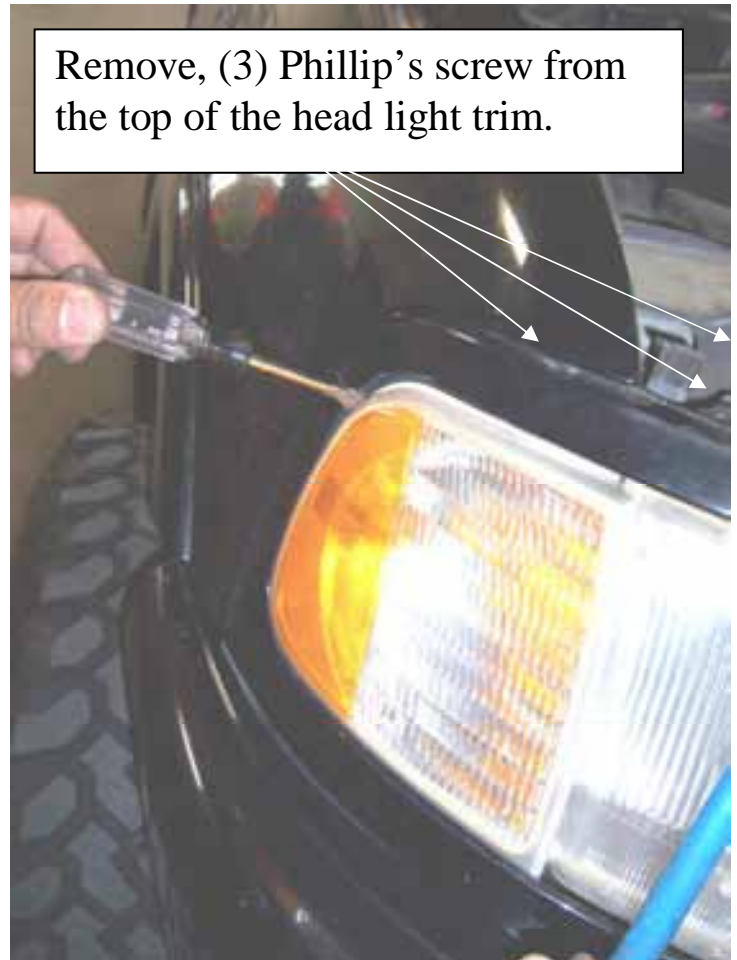

3) Remove fender:

Remove the (2) exposed 8mm bolts. Pull on the light trim this will allow you to remove (2) 8mm bolts that are behind the light trim bracket

Remove (1) 8mm bolt behind bumper.

(Figure 2) Lift up on the windshield plastic cover and remove (1) 8mm bolt. Remove the rest of the 8mm bolts from the top lip of the fender.

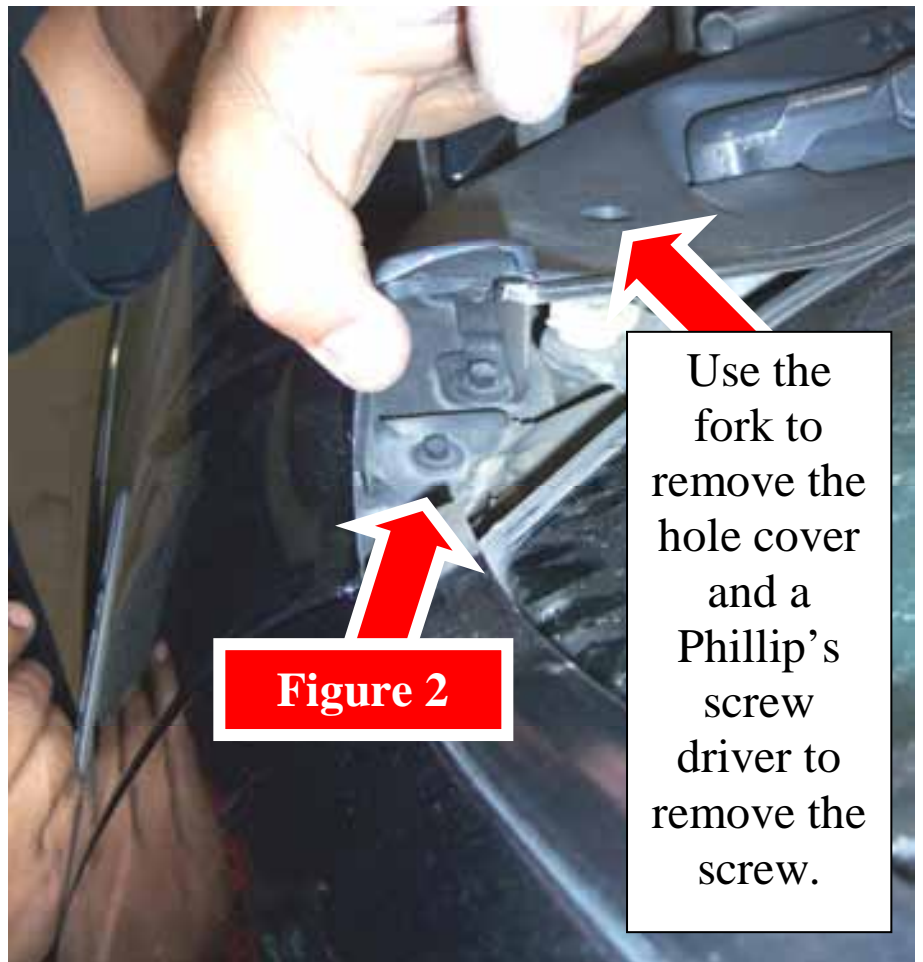

Use the fork to remove the hole cover and a Phillip's screw driver to remove the screw.

Remove (4) 7/32 screws from the wheel well and any other fasteners holding it.

You will also need to remove (2) 8mm bolts located by the bottom of the door on the chassis.



To remove the remaining (2) 8mm bolts (figure A), you will have to pull on the wheel well and remove the plastic or foam that cover the factory hinges (figure B). After removing the foam you will be able to remove the (2) 8mm bolts that are located by the factory hinges.



At this point use the fork on the front by the head light to help you remove the fender.

4) Remove the door catch. Remove (1) T-30 Torx screw and (2) 8mm nuts. Push the door catch inside the body



To remove the door catch from the body you will have to take out the door trim and foot trim so that your car looks similar to the picture at the bottom.



5) Remove door panel:
Remove (1) 8mm nut this will allow you to remove the door handle (figure C). Apply pressure straight up to remove the control panel (figure D).

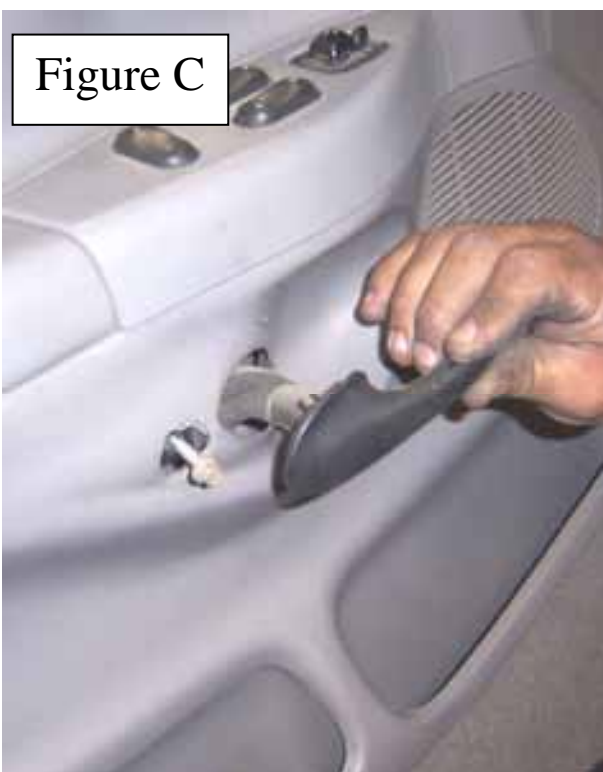

Unplug the wire harness (figure E) and use the fork to remove the plastic clips in the front (figure F) and back (figure G) holding the door panel in place after you have remove the clips pull on the door panel and unplug the small light (figure H) on the back of the door panel. At this time you should be able to remove the door panel.

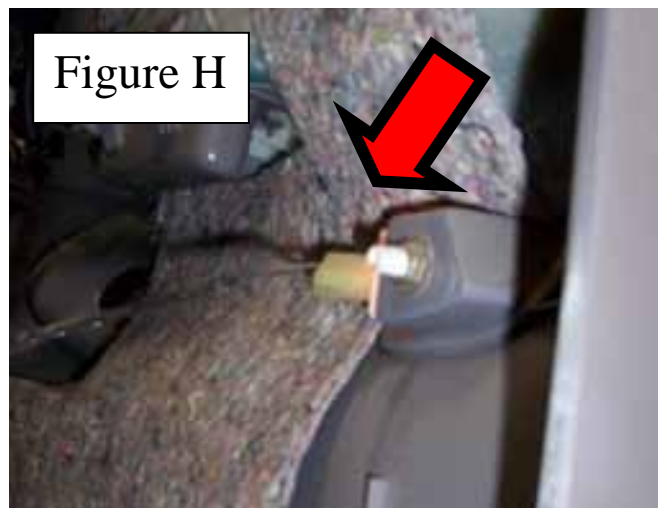
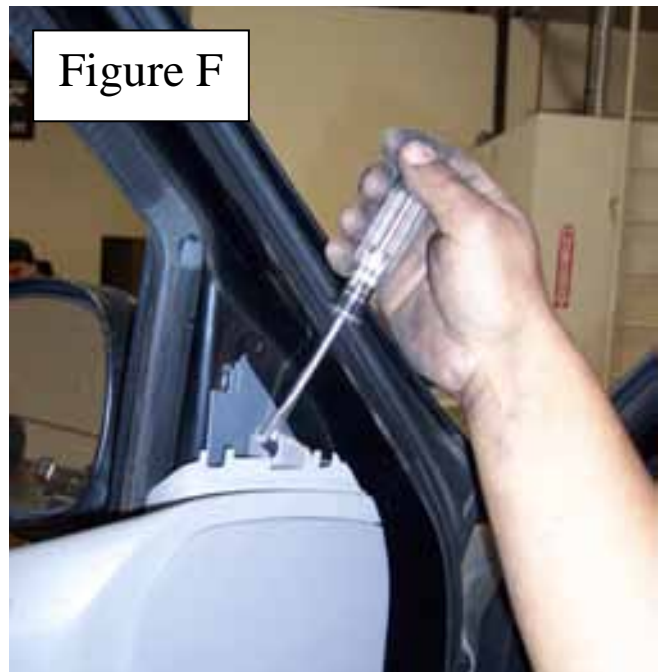
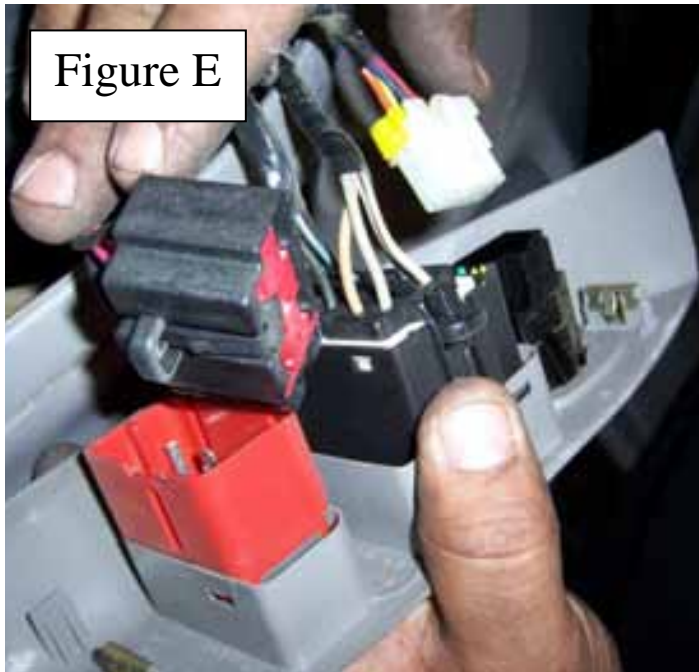

6) Modify wire layout:

You will need more wire slack in order for the Vertical Doors Inc. system to open all the way up. Use the fork to remove (3) plastic clips to gain more wire slack from the door.



7) Close door and use painter's tape to secure the door in preparation for factory hinge removal.

Use a 13mm socket to remove the factory hinges.

Hint (You can make your spacer out of paint sticks and about 8-10 turns of blue painters tape)*



Add the spacers after you have removed the factory hinge.

8) After you have removed the original door hinges, install the New Vertical Doors Inc. System. Make sure all mounting surfaces are flat.

Hint Install the bolts on the door first then the bolts on the body second.*



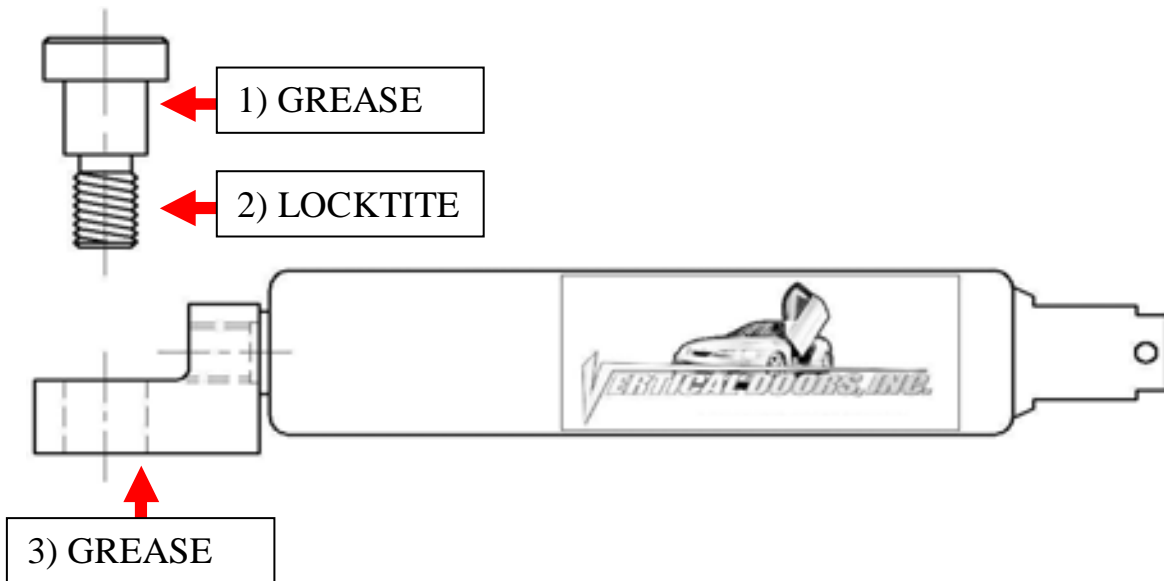

***IMPORTANT STEP: DO NOT SKIP THIS STEP. THIS STEP IS CRUCIAL IN YOUR INSTALLATION PROCESS, IF THIS STEP IS NOT COMPLETED WHEN INSTALLING THE VERTICAL DOOR KIT; ALL WARRANTIES ARE VOIDED, AND MAY CAUSE FUTURE PROBLEMS WITH YOUR VERTICAL DOOR SYSTEM.**

1ST, make sure you put grease on the body of shoulder bolt where the arrow is pointing.

2ND, make sure you put red Loctite, where the arrow is pointing, on thread of shoulder bolt.

3RD, make sure you put grease on the bottom side of the shock end.



WARNING! THE USE OF ANY TYPE PLYERS, PAINT OR FOREIGN MATERIALS ON THE SHOCK'S BODY OR SHAFT WILL VOID THE WARRANTY.

7) Once hinge is locked in place, break nut #1 then turn Allen set screw #2 on fig until it hits the block then open the door and continue to adjust until the door matches with the striker, open and close door making sure it closes like factory.

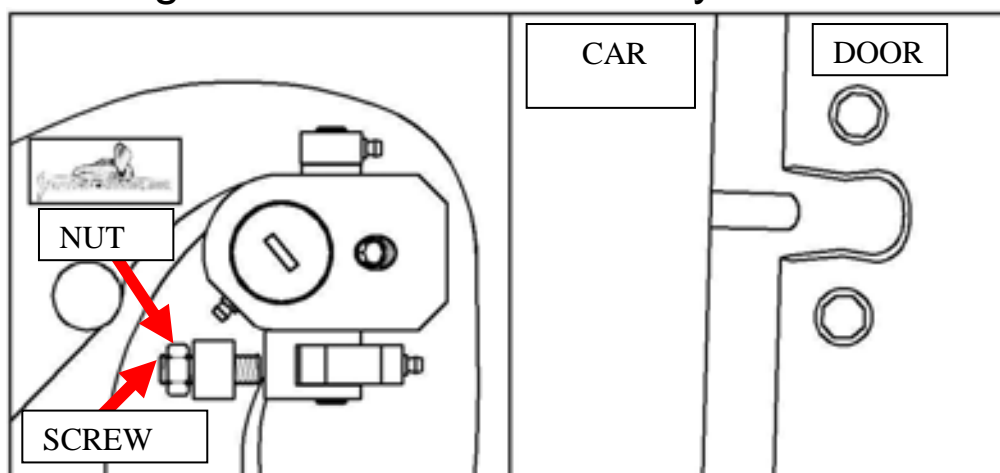

Hint(leave #1 nut loose until shock is installed Allen set screw will have to be re-adjusted after shock is installed.*

8) Install the shock.

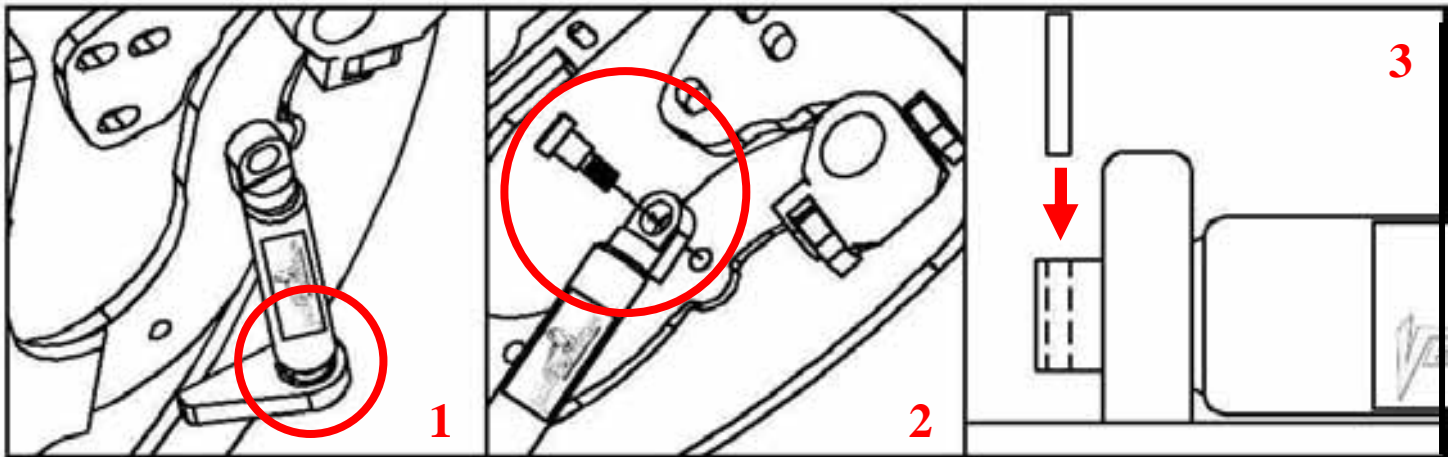

Hint (You will need a helper to raise the door). (Slip the spherical rod mount into the spherical ball bearing (1). Using a 1/4 Allen wrench, tighten the screw into the swing arm (2). After the shock is installed secure it by installing the pin in the bottom shock end (3).*

11) After shock is installed re-install door panel and lift the door. Adjust door opening screw #3 clockwise until distance between nub and swing arm is enough so that the swing arm moves up and down freely.

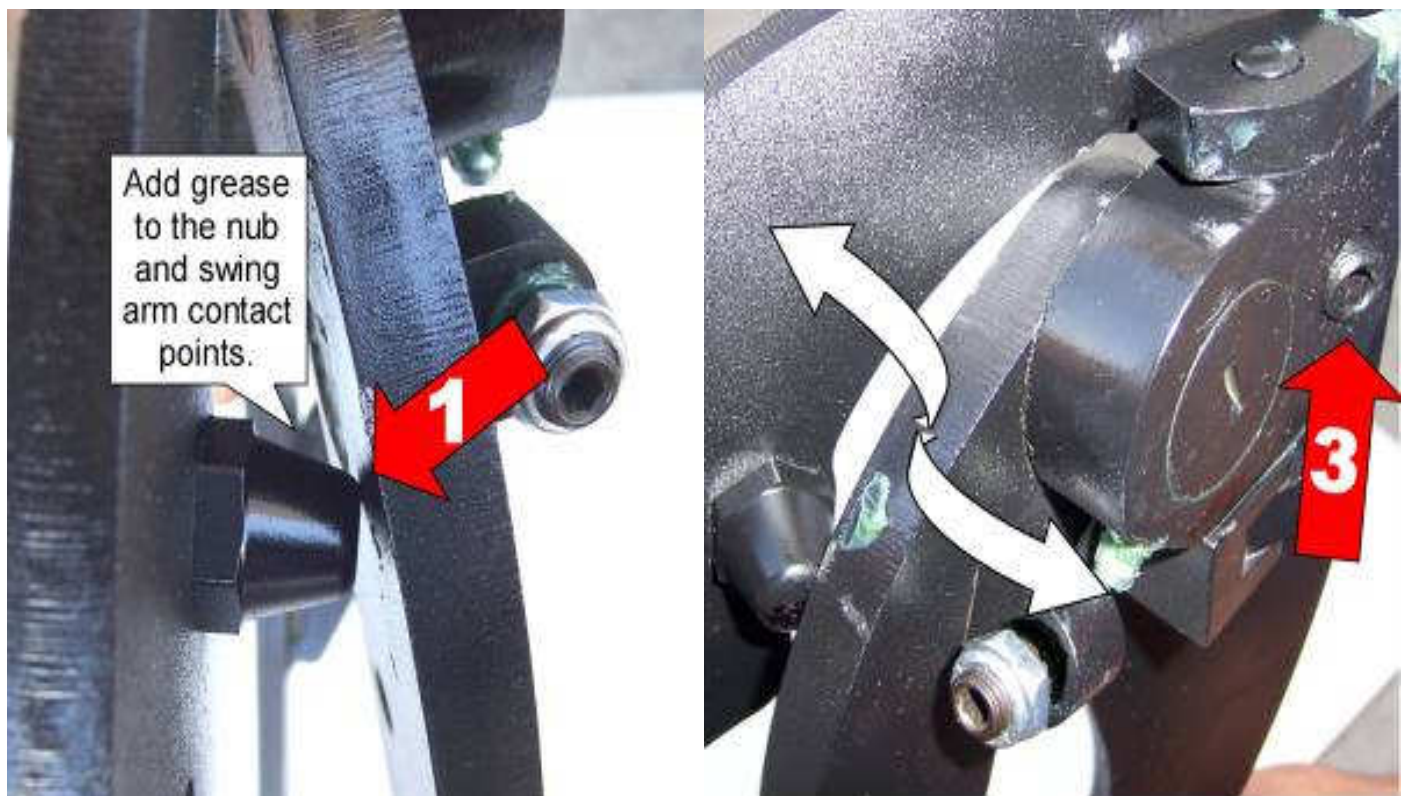

Hint (Fine tune the Allen set screw (#2) to realigned striker with door. After the door is aligned, test door by opening and closing, lifting and lowering door several times.*

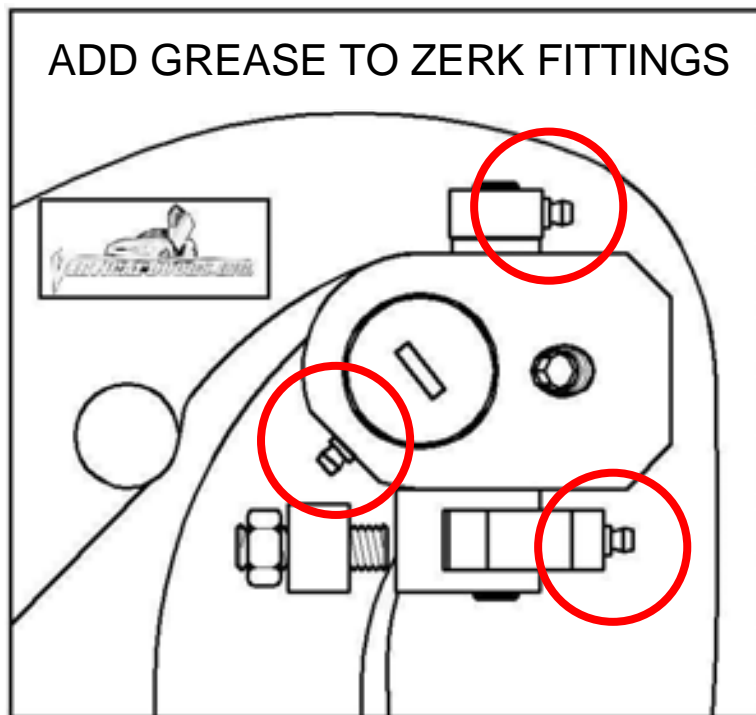

Note: Do not install fender until the adjustment of the door is accurate, and the set screw is tightly secure. Also make sure everything is tight, adjustment is set and everything is Loctite.

12) Modify factory wire loom. You will have to open and raise the door, cut the factory wire loom in half and add included wire loom to protect exposed wires.

13) Cut the inner lip of your fender to make room for the new Vertical Doors hinge. Note: After you have cut the fender use a sander or grinder and make sure the surface is completely flat.

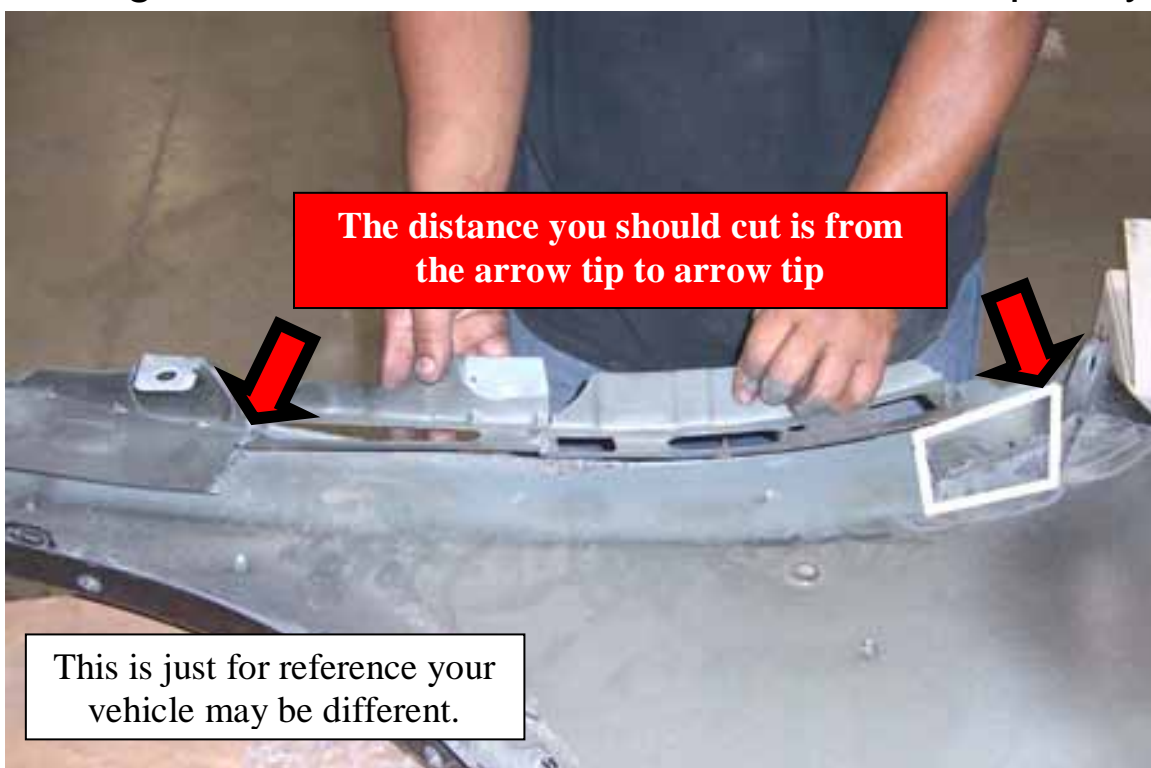

14) Replace the door panel.

15) Lift the door and Replace the fender by reversing step 2 and 3.

Hint(Make sure the electrical wires don't get pinched enough to damage wires)*

16) For the other side just follow steps 2-15.

**Thank you for your purchase of the
FORD F-150 1997-2002**