



300C 2005-2006

INSTRUCTIONS

Made in USA

U.S. PATENT

#6,808,223; #6,845,547;

#7,140,075; #7,059,655

and other patents pending.



THIS KIT INCLUDES:

- 2 PINS
- RIGHT AND LEFT HINGE ASSEMBLY
- 2 SHOCKS 565 PSI
- 2 SHOULDER BOLTS WITH WASHERS

TOOLS REQUIRED FOR INSTALLATION:

	<ul style="list-style-type: none"> ➤ AIR RACHET, GRINDER AND CUTTER.
	<ul style="list-style-type: none"> ➤ 7MM, 8MM, 10MM, 11MM, 13MM, SOCKETS AND EXTENSION.
	<ul style="list-style-type: none"> ➤ FORK AND PHILLIP'S SCREW DRIVERS
	<ul style="list-style-type: none"> ➤ SPACERS FOR THE DOOR GAP.
	<ul style="list-style-type: none"> ➤ 3/16 ALLEN WRENCH
	<ul style="list-style-type: none"> ➤ 1/4 TORX BIT
	<ul style="list-style-type: none"> ➤ 9/16 WRENCH
	<ul style="list-style-type: none"> ➤ LOCKTITE RED

OTHER TOOLS MAY BE NEEDED DEPENDING ON YOUR VEHICLE.

(Note: The pictures on the manual are for reference only they may not match your vehicle.)

1) Disconnect the battery.

2) Remove fender. Remove all Plastic clips that hold the splash guard to fender, using the fork screwdriver

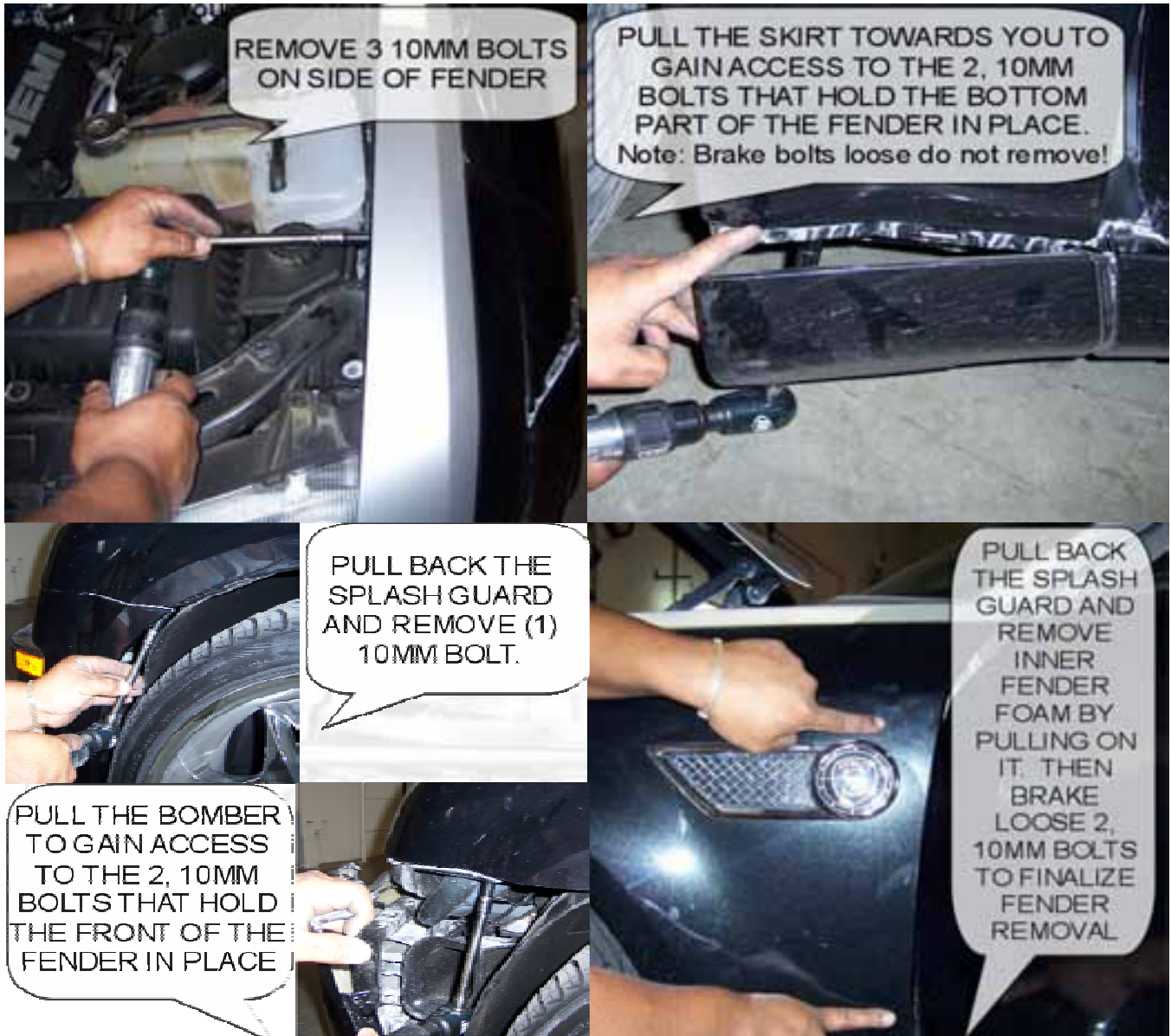

To remove the fender lift up the top of the fender toward you and then slip out the bottom end.

3) Modify the spot where the New Vertical Doors hinge will be located. Note: surface must be completely flat before installing the New Vertical Doors hinge.



4) Unplug the wire harness.



5) Close door and use painters tape to secure the door in preparation for factory hinge removal.

Hint (You can make your spacer out of paint sticks and about 8-10 turns of blue painters tape)*

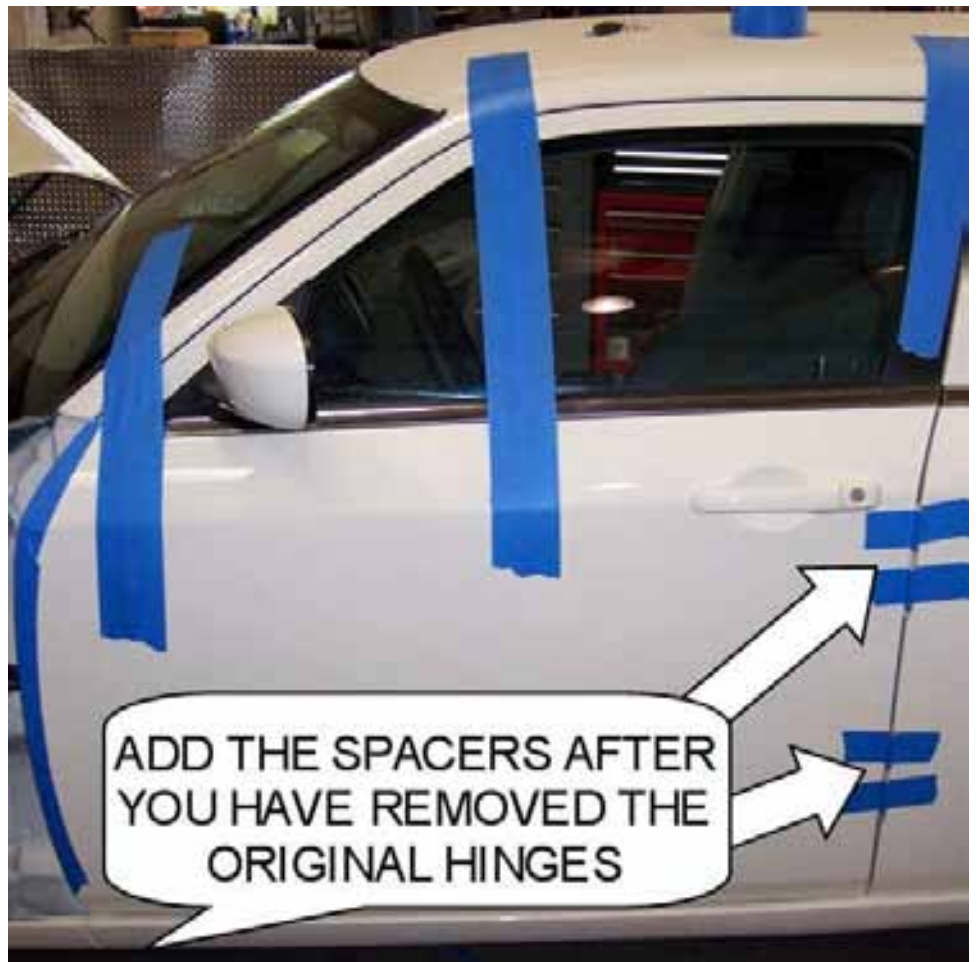

6) Remove original door hinges and Install the New Vertical Doors Inc. System.

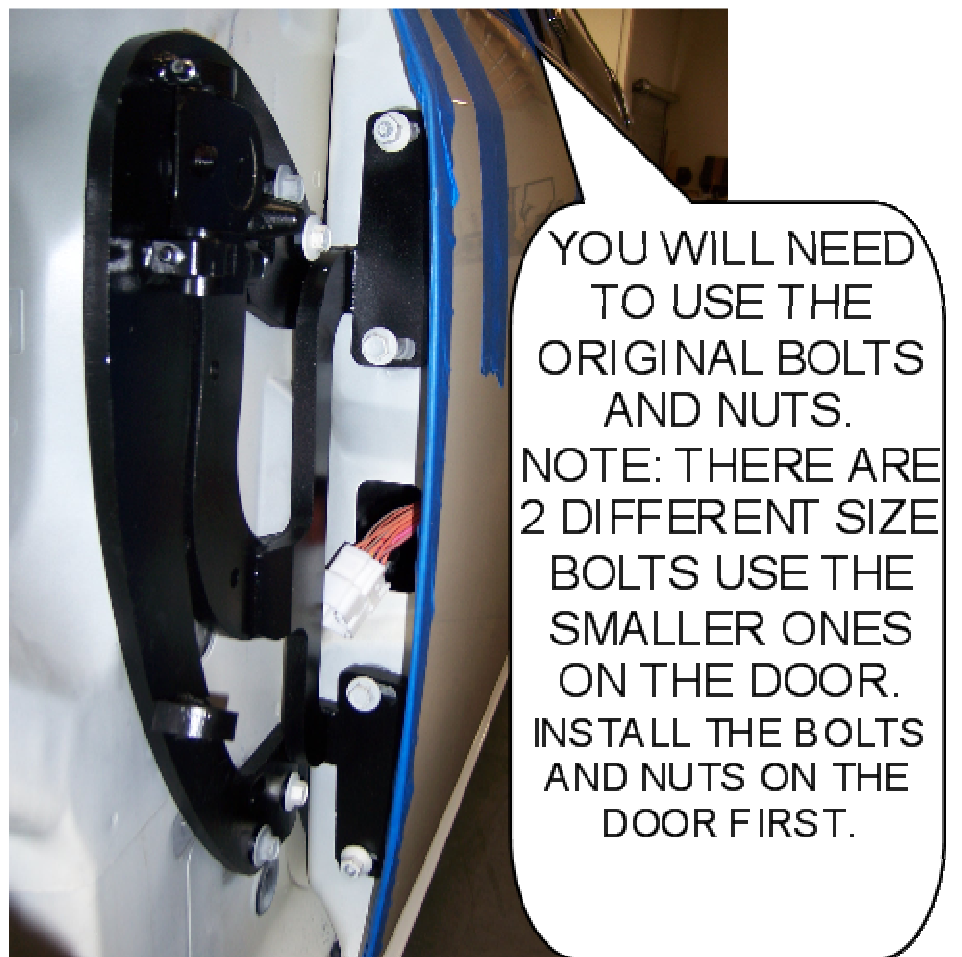

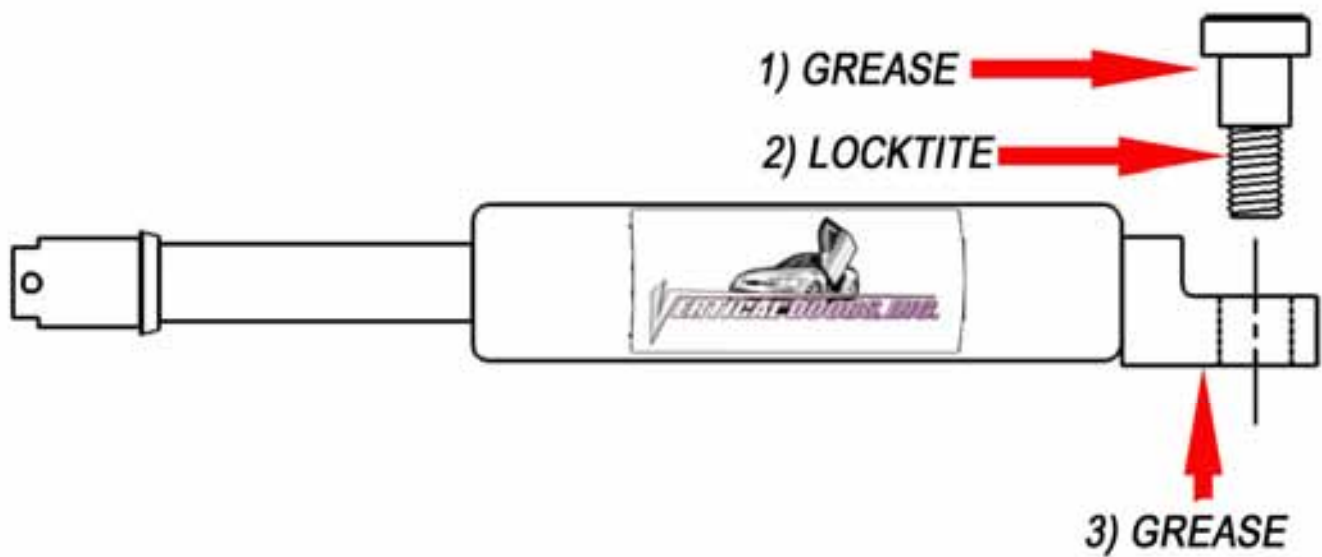

****IMPORTANT STEP: DO NOT SKIP THIS STEP. THIS STEP IS CRUCIAL IN YOUR INSTALLATION PROCESS, IF THIS STEP IS NOT COMPLETED WHEN INSTALLING THE VERTICAL DOOR KIT; ALL WARRANTIES ARE VOIDED, AND MAY CAUSE FUTURE PROBLEMS WITH YOUR VERTICAL DOOR SYSTEM.***

1ST, make sure you put grease on the body of shoulder bolt where the arrow is pointing.

2ND, make sure you put red Locktite, where the arrow is pointing, on thread of shoulder bolt.

3RD, make sure you put grease on the bottom side of the shock end.



WARNING! THE USE OF ANY TYPE PLYERS, PAINT OR FOREIGN MATERIALS ON THE SHOCK'S BODY OR SHAFT WILL VOID THE WARRANTY.

7) Once hinge is locked in place, break nut #1 then turn Allen set screw #2 on fig until it hits the block then open the door and continue to adjust until the door matches with the striker, open and close door making sure it closes like factory.

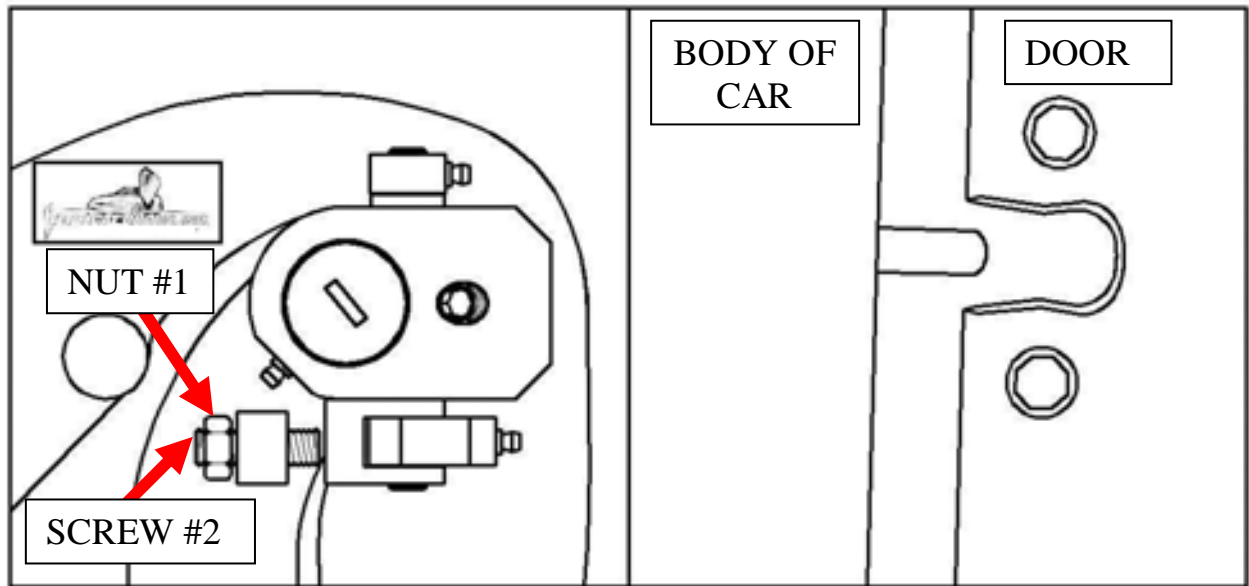

Hint(leave #1 nut loose until shock is installed Allen set screw will have to be re-adjusted after shock is installed.*

8) Install the shock.

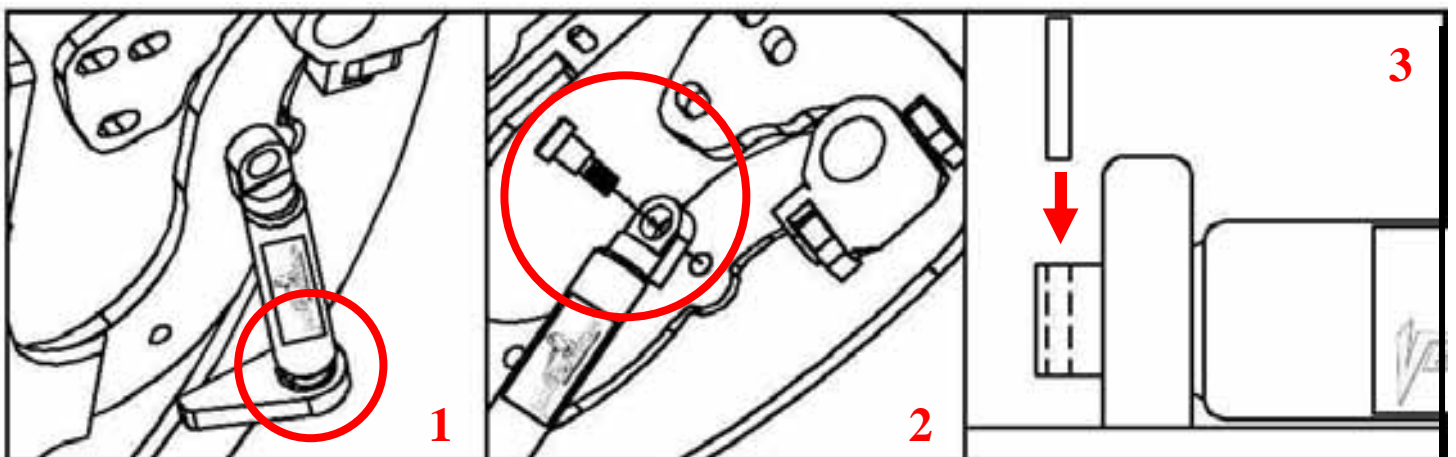

Hint (You will need a helper to raise the door). (Slip the spherical rod mount into the spherical ball bearing (1). Using a 1/4 Allen wrench, tighten the screw into the swing arm (2). After the shock is installed secure it by installing the pin in the bottom shock end (3).*

9) After shock is installed re-install door panel and lift the door. Adjust door opening screw #3 clockwise until distance between nub and swing arm is enough so that the swing arm moves up and down freely.

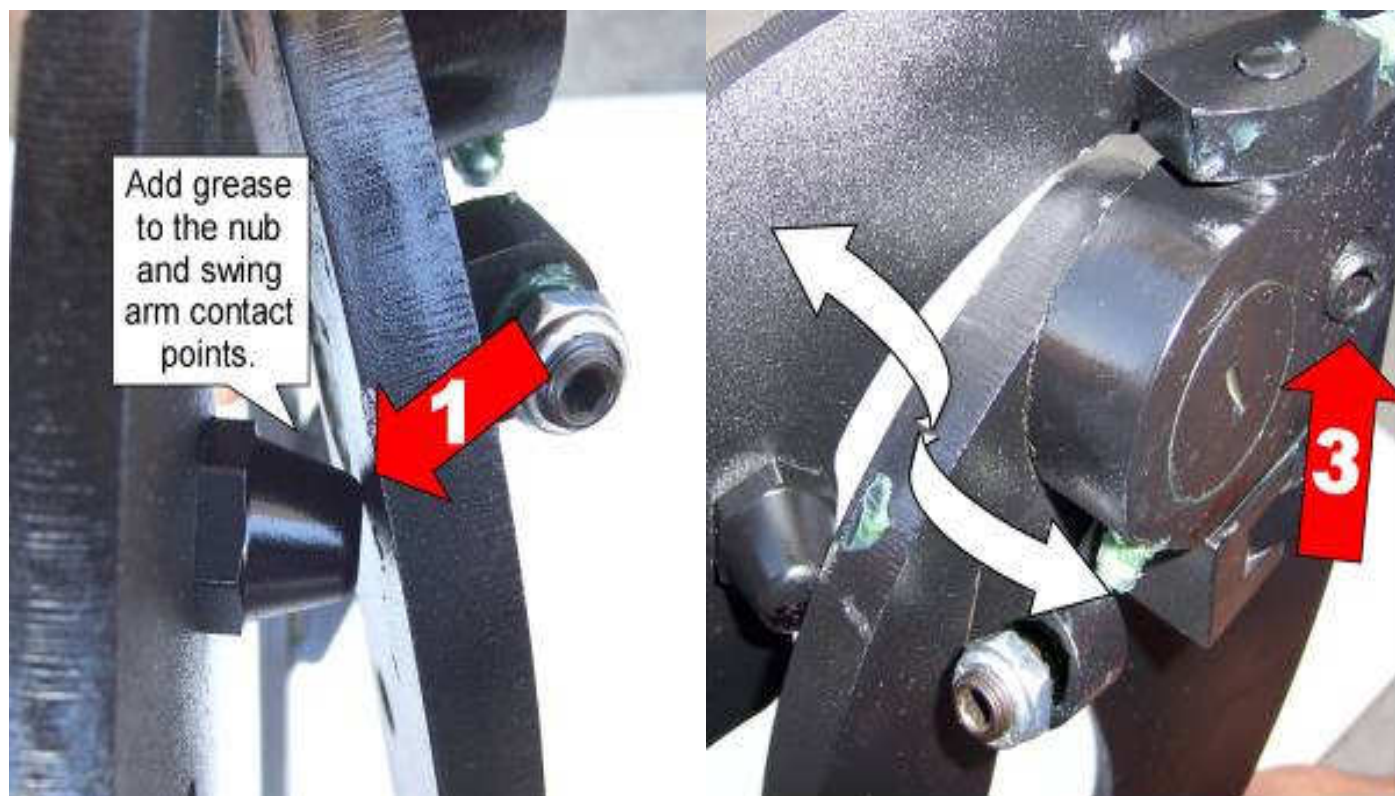

Hint (Fine tune the Allen set screw (#2) to realigned sticker with door. After the door is aligned, test door by opening and closing, lifting and lowering door several times.*

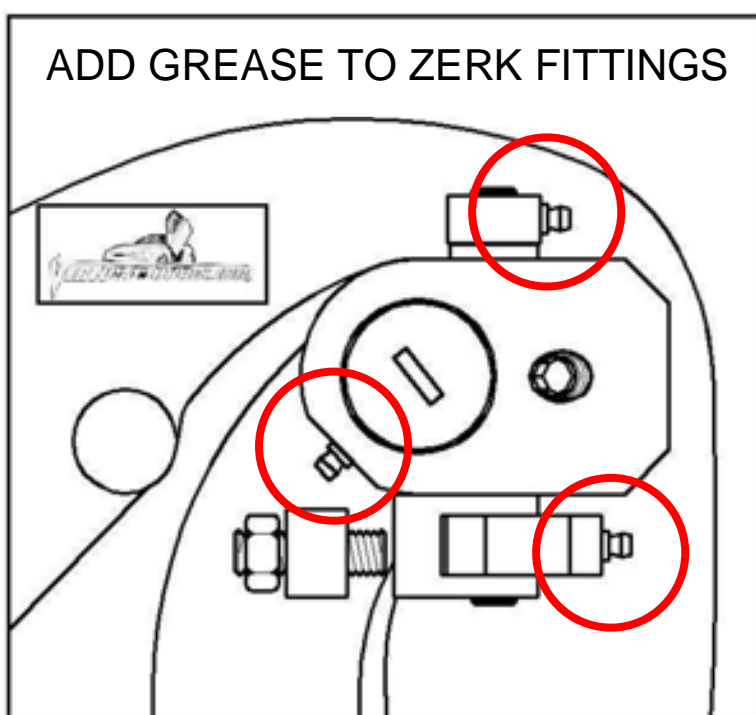

Note: Do not install fender until the adjustment of the door is accurate, and the set screw is tightly secure. Also make sure everything is tight, adjustment is set and everything is Loctite.

10) Modify wire layout.



11) Cut the inner lip of your fender to make room for the new Vertical Doors hinge.

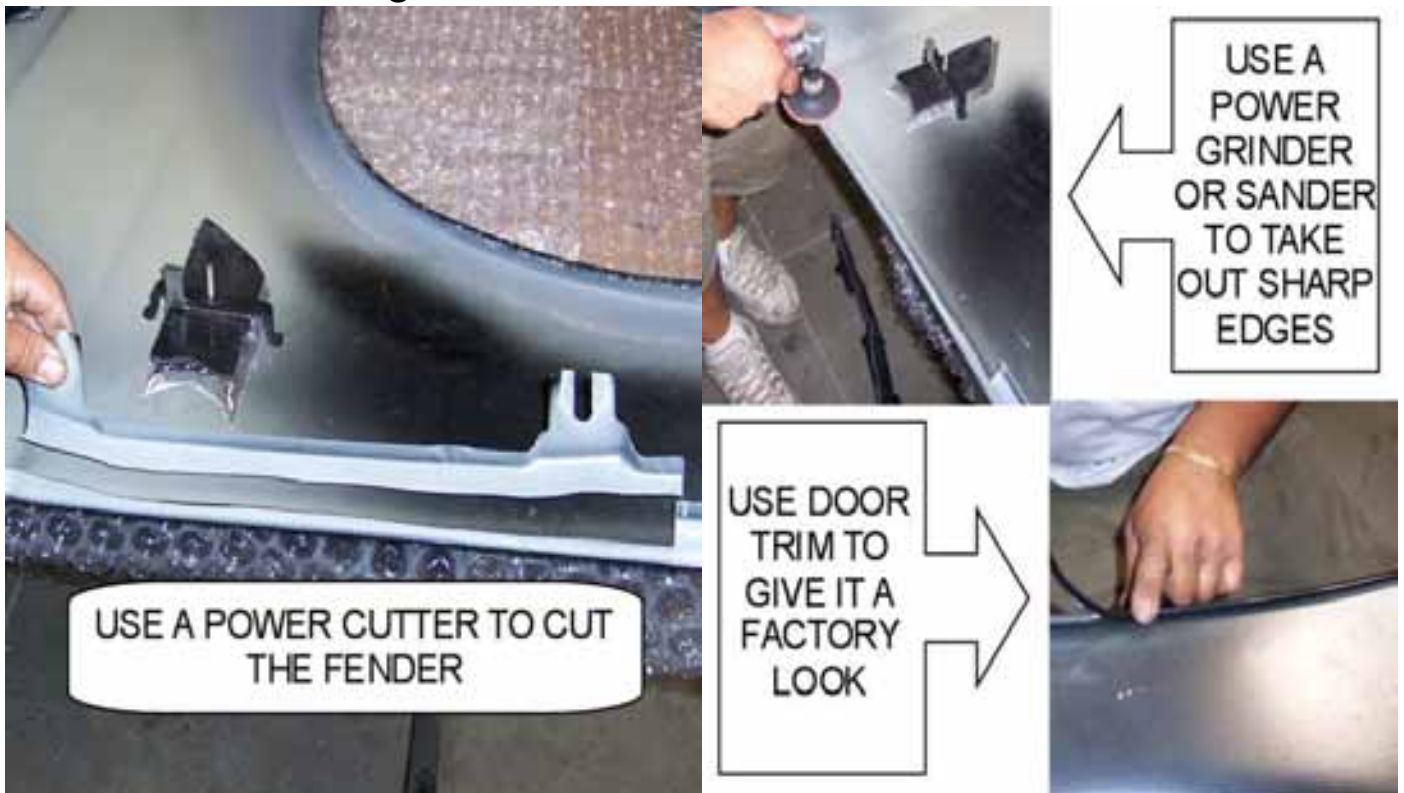

12) Lift the door and Replace the fender by reversing step 2.

Hint(Make sure the electrical wires don't get pinched enough to damage wires)*